



CITY of NOVI CITY COUNCIL

Agenda Item L
December 17, 2012

SUBJECT: Approval to purchase a replacement backup generator for the Island Lake sanitary sewage lift station (Lift Station No. 1), located at the northeast corner of Wixom Road and Albatross Drive, to American Generators Sales & Service, LLC, the lowest responsive bidder, in the amount of \$28,985.

SUBMITTING DEPARTMENT: Department of Public Services, Water & Sewer Division *BR*

CITY MANAGER APPROVAL: *[Signature]*

EXPENDITURE REQUIRED	\$ 28,985
ADDITIONAL AMOUNT REQUIRED	\$ 0
LINE ITEM NUMBER	592-000.00-142.000 (Water & Sewer Fund)

BACKGROUND INFORMATION:

The engine on the backup power generator for the Island Lake sanitary sewage lift station suffered a catastrophic failure during a routine load test performed in October. Because the generator is over ten years old and has had a history of frequent and sometimes costly repairs, staff recommends the complete replacement of the unit in lieu of replacing only the engine (Bob West's October 30, 2012 memorandum is attached for reference).

Staff prepared the attached Invitation to Bid (ITB) and solicited competitive bids for a replacement generator in November. A total of eight bids were received on December 5, 2012. The lowest bid price of \$28,549 was submitted by W.W. Williams Company; however, Williams' bid is non-responsive because:

1. The power requirement called for in the ITB's specifications is 80kW to 90kW and Williams proposed a 75kW unit.
2. The ITB's specifications include a requirement that shipping is to be "FOB-Destination" - meaning the vendor is responsible for the cost of shipping and risks during transportation of the unit. Williams' bid indicates that shipping would be "FOB-Factory Freight Allowed", which means that even though the vendor pays for freight costs, the City would hold title to the generator and be responsible for filing claims for loss or damage during shipping.
3. The specifications also state that the City will make payment within 30 days of receipt of the vendor's invoice, but Williams' bid indicates that payment would need to be made upon delivery of the unit.

The second lowest bid was submitted by American Generators Sales & Service, LLC in the amount of \$28,985. American Generator's bid is responsive because it meets all of the requirements included in the ITB. Delivery and installation of the replacement generator will occur by February 2013.

American Generator has been providing generator maintenance services for the City since 2011.

RECOMMENDED ACTION: Approval to purchase a replacement backup generator for the Island Lake sanitary sewage lift station (Lift Station No. 1), located at the northeast corner of Wixom Road and Albatross Drive, to American Generators Sales & Service, LLC, the lowest responsive bidder, in the amount of \$28,985.

	1	2	Y	N
Mayor Gatt				
Mayor Pro Tem Staudt				
Council Member Casey				
Council Member Fischer				

	1	2	Y	N
Council Member Margolis				
Council Member Mutch				
Council Member Wrobel				

MEMORANDUM



TO: ROB HAYES, DPS DIRECTOR/CITY ENGINEER
FROM: ROBERT M. WEST, WATER & SEWER MANAGER
SUBJECT: ISLAND LAKE LIFT STATION GENERATOR
DATE: OCTOBER 30, 2012

All City-owned generators are serviced by American Generators, LLC, which performs repairs and routine and preventative maintenance, including a standard load bank test annually to ensure the generators function properly at their specified peak rating. During a recent load bank test of the standby generator located at Island Lake Lift Station #1 (located on Wixom Road between Ten Mile and Eleven Mile), the engine component of the generator failed resulting in damage beyond repair.

Based on the history of repairs over the last year, my recommendation is to replace the generator as a whole unit as opposed to replacing the damaged engine only. The unit is over 10 years old and has had many electrical and mechanical repairs, primarily as a result of the sub-standard enclosure's exposure to severe weather. This table lists recent repairs and their costs:

Island Lake L/S #1 FY2011-12 Repair Costs

Date	Repair	Costs
5/15/2012	Battery charger	\$ 810.00
4/26/2012	Voltage sensing board	\$ 451.40
4/20/2012	Dead battery	\$ 300.00
12/6/2011	Radiator	\$ 3,479.65
11/3/2011	Block heater	\$ 264.75
10/5/2011	New engine head	\$ 2,638.86
10/5/2011	Fuel regulator	\$ 996.07
	Total	\$ 7,379.33

The costs associated with the installation of a new generator are estimated not to exceed \$35,000. Specifications would be prepared and submitted to the Purchasing Division to procure the installation of an equivalent generator from a qualified vendor. Because delivery time is estimated to be seven weeks, in the interim we would use the towed 150 kW generator in the Water & Sewer fleet as a backup power source in the event of a loss of normal power at Island Lake Lift Station #1. This unit would remain on standby at the Field Services Complex rather than left on site.

Please contact me if you concur with this recommendation, or if you have any questions or comments regarding this matter.

cc: Nevrus Nazarko, Finance Director
Tina Glenn, Assistant Treasurer
Becky Arold, Fleet Manager/Analyst Planner



Generac SG080 Generator with Enclosure

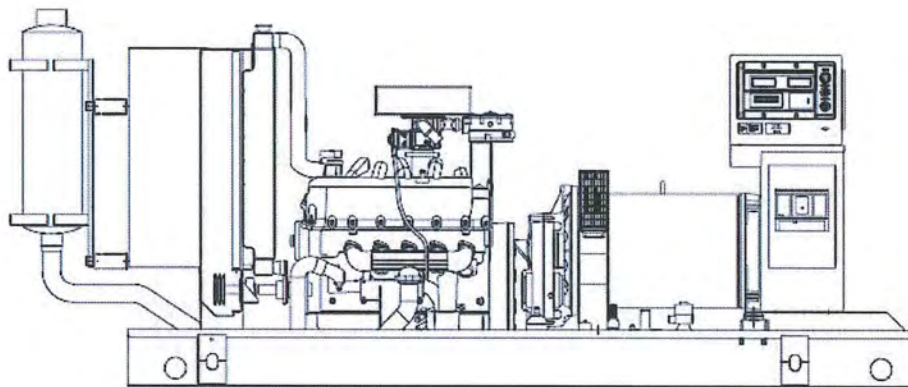

Schematic of Generac SG080 Generator without Enclosure

W.W. WILLIAMS' BID



**CITY OF NOVI
BID FORM**

LIFT STATION GENERATOR

We the undersigned, as bidder, propose to furnish to the City of Novi, according to the terms, conditions, and instructions attached hereto and made a part thereof:

A. Lift Station Generator \$ 28,549.00 Lump Sum

Make/Model MTU Onsite Energy GS0075-6S

B. Transfer Switch (choose one)

- We are able to use the existing transfer switch.
- We are unable to use the existing transfer switch. The additional cost for a new transfer switch is \$ _____.

Delivery date 3/22/2013 (Estimated)

Warranty: 2 year or 3000 hour standby limited warranty

REFERENCES: Please provide at least three client (3) references for projects of similar scope done in the last 3 years.

Company Village of Union City

Address 208 N. Broadway, Union City, MI 49094

Phone 517-741-8591 Contact name James Campfield

Company Kimball Midwest

Address 4800 Roberts Rd., Columbus, OH 43228

Phone 614-219-6100 Contact name Richard Greer

Company Lancaster Police Department

Address 130 S. Broad St., Lancaster, OH 43130

Phone 740-687-6688 Contact name Dave Baily

EXCEPTIONS TO SPECIFICATIONS (all exceptions must be indicated here):

None

COMMENTS: None

We acknowledge receipt of the following Addenda: 127624-1-1 & 127624-2-1
(please indicate numbers)

THIS BID SUBMITTED BY:

Company (Legal Registration) W.W.Williams Co.

Address 4000 Stecker St.

City Dearborn State MI Zip 48126

Telephone 800-338-1989 Fax 313-584-1444

Representative's Name (please print) Michael D. Peters

Representative's Title Onsite Energy Territory Manager

Representative's Signature 

E-mail mpeters@wwwilliams.com

Date 12/04/2012



**CITY OF NOVI
LIFT STATION GENERATOR**

Please return this page with your bid form

If your company is awarded the item(s) referenced in the bid proposal, other governmental entities may wish to use this contract and will issue a purchase order or contract for the item(s) awarded in the bid proposal following minimum order/contract requirements set forth in the bid documents. Each entity will provide their own purchase order and delivery location(s) and must be invoiced separately to the address indicated on their purchase order.

**1. EXTENSION OF AWARD TO THE MITN (MICHIGAN INTER-GOVERNMENTAL TRADE NETWORK)
PURCHASING COOPERATIVE: OPTIONAL**

Numerous Counties, Cities, Townships, and Authorities of the State of Michigan are members of the MITN (Michigan Inter-governmental Trade Network) Purchasing Cooperative. Other associate entities are also members of the Cooperative in the Tri-County area. Please visit www.mitn.info website to view the entire list of participating agencies.

() If an award is made to N/A, it is agreed that the contract will be extended to other MITN Purchasing Cooperative members and associate entities under the same prices, terms, and conditions.

(X) Our company is **NOT** interested in extending the contract to those MITN members listed on the website.

2. EXTENSION OF AWARD TO THE CITY OF NORTHVILLE: OPTIONAL

The City of Novi is working with the Novi Community School District, City of Northville, Northville Community School District and the Walled Lake Consolidated Schools to discover opportunities to optimize procurement services.

() If an award is made to N/A, it is agreed that the contract will be extended to Novi Community School District, City of Northville, Northville Community School District and the Walled Lake Consolidated Schools under the same prices, terms, and conditions.

(X) Our company is **NOT** interested in extending the contract to Novi Community School District, City of Northville, Northville Community School District and the Walled Lake Consolidated Schools under the same prices, terms, and conditions.

Contractor Signature: _____

Company Name: W.W. Williams Co.

Date: 12/04/2012

W.W.Williams®

Consider It Done.

QUOTATION NO. ME1211161

BID DATE: November 16, 2012

TO: City Of Novi
45175 W. Ten Mile Rd.
Novi, MI 48375-3024

REPLY TO: 4000 Stecker Ave.
Dearborn, MI 48126

E-mail: mpeters@www.williams.com
Cell: 586-484-6396

ATTN: Sue Morianti
VIA EMAIL: smorianti@cityofnovi.org
PROJECT: City of Novi WWTP

Application: Generator Set Terms: Net on Delivery. Terms on request subject to credit approval. Delivery: Subject to production availability at time of release FOB: Factory freight allowed

MTU Onsite Energy Model: GS00075-6S-NB0994

- Generator 75 KW, 87.5 KVA, 105 Amps, 0.8 PF
- 480 Volt, 3 phase, 12 wire, 60 Hertz
- 130 degree temperature rise
- Ratings are in accordance with ISO 3046-1, BS 5514, AS 2789, and DIN 6271
- MTU Onsite Energy is a single source supplier
- Engine-generator resilient mounted
- 2/3 pitch windings
- Sustained short circuit current of up to 300% of rated current for up to 10 seconds
- Self ventilated and drip proof, superior voltage wave form, no load to full load regulation, digital solid state volts per hertz regulator
- Brushless alternator with brushless pilot exciter, four (4) pole rotating field, 130 degrees max standby temperature rise
- One (1) sealed bearing, full amortisseur windings, 125% rotator balancing, 100% of rated load- one step per NFPA 110, three (3) phase voltage sensing, plus/minus 1% voltage regulation, 3% maximum harmonic content
- Engine-generator set is designed and manufactured in facilities certified to standards ISO 9001:2008 and ISO 14001:2004
- Engine-generator set tested to ISO 8528-5 for transient response
- UL2200 listed

Engine:

- Ford natural gas engine model 6.8LT, 4-cycle, Vee 10, 1800 rated rpm, BHP 114.8
- Bosch electronic isochronous engine governor
- EPA certified engine
- Dry fuel strainer with base plumbing factory installed

Control Panel:

- DGC 2020 level 1 with expanded outputs, UL recognized, CSA certified, NFPA 110
- All generator protection features are programmable as alarms pre alarms or not used.
- Engine alarms (shutdowns): low oil pressure, high coolant temp, low coolant level, low fuel level, over speed, over crank, engine sender unit failure, e-stop, battery charger failure
- Engine pre alarms (warnings): low oil pressure, high coolant temp, low coolant temp & level, battery overvoltage, week battery, battery charger failure, engine sender failure, engine KW overload (3 levels), Maintenance timer

Circuit Breaker:

- 125 amp H frame 3 pole 80% rated standard circuit breaker
- Circuit breaker factory installed
- All breaker accessories are wired to a terminal strip for customer connection

Other Components:

- -20 deg F block heater, 120 volt, 1 phase, 1800 watts
- Block heater factory mounted and wired
- Two (2) isolation valves
- Standard duty air filter
- Battery rack and acid
- Guest battery charger model 12-6A
- Factory mounted and DC wired
- Pad isolators
- Two (2) hour load bank test at time of WW Williams commissioning (start-up)

COP

Paint:

- ANSI 61 Gray (standard)

Factory Testing:

- MTU Onsite Energy engine generator sets are compliant with many different codes and standards. MTU Onsite Energy's philosophy and performance are regularly reviewed to ensure continuity with these codes and standards: UL2200, CSA, EPA, NFPA 99—Health Care Facilities, NFPA 70—National Electrical Code, NFPA 110—Standard for Emergency and Standby Power Systems, Department of Labor and Industry, ISO 8528-5—Generating Sets, and ISO 8528-9 Measurement and Evaluation of Mechanical Vibrations. In addition: ISO 8528-10--Measurement of airborne noise by the enveloping surface method, IEEE 115--Test Procedures for Synchronous Machines, NEMA MG 1--Motors and Generators, MIL-STD-705-c.
- MTU Onsite Energy performs prototype and factory testing by following the methods and guidelines established by MIL-STD-705c. MTU Onsite Energy is proud to perform these stringent procedures because they showcase engine generator set superiority in providing precise power for all types of critical applications including hospitals, data centers, UPS systems and government and military installations.
- Performance Assurance Certification (PAC)
- Verified product design, quality and performance integrity

Generator Enclosure:

- Level 3 advanced sound attenuation steel enclosure
- Internally mounted hospital grade silencer
- 150 MPH wind rating
- Exhaust scoop with foam kit
- Sound attenuated polyether polyurethane foam 1.5" of 2.15 lbs/c3
- Foam meets UL94 flame resistance
- 61.5 dB(A) at 7 meters (23 feet) sound rating
- Modular design with secure locking double doors
- UL2200 Listed
- Factory assembled and installed
- Rodent proof construction
- High retention gloss paint
- ISO 9001 : 2008

Shipped:

- Unit shipped wet (fluids installed)
- Unit shipped with 1 manual

Warranty:

- 2 year or 3000 hour basic standby limited warranty

Installation:

- Installation performed by a licensed electrical contractor
- All permitting as required by the City of Novi
- Removal and disposal of failed generator
- Removal and disposal of un-level existing concrete pad
- Installation of new level concrete pad
- Connection of gas plumbing
- Re-use of existing underground conduits and wiring to the Automatic Transfer Switch
- Replacement of Automatic Transfer Switch is not required

TOTAL QUOTED PROJECT PRICE\$28,549.00
 (Price does not include sales tax, if applicable)



THE ABOVE PRICE INCLUDES:

- **F.O.B. - FACTORY FREIGHT ALLOWED – VIA COMMON CARRIER IN A “CLOSED TRAILER” TO FIRST DESIGNATED LOCATION. ANY CHANGES AFTER SHIPMENT WILL RESULT IN ADDITIONAL CHARGE.**
- **DELIVERY DOES NOT INCLUDE OFF-LOADING**
- **NO CABLE/WIRE/TERMINATIONS INCLUDED**
- **JOBSITE START-UP INSPECTION INCLUDES ONE (1) TRIP WITH BANK TEST USING AVAILABLE LOAD, TO BE COMPLETED DURING NORMAL BUSINESS HOURS OF 7:00 AM – 3:30 PM, MONDAY THRU FRIDAY (EXCLUDING HOLIDAYS). ADDITIONAL TRIPS OR HOURS ONSITE, DUE TO CONSTRUCTION OR OTHER DELAYS BEYOND OUR CONTROL, WILL BE BILLED AT EXTRA COST AT PREVAILING RATES.**
- **TRAINING OF OPERATING PERSONNEL**
- **TERMS SUBJECT TO CREDIT APPROVAL**

NOTES AND CLARIFICATIONS:

- **NO FUEL TANK TESTING PROVIDED**
- **NO FUEL OR FUEL FOR TESTING PROVIDED**
- **GENERATOR WILL SHIP VIA COMMON CARRIER, CLOSED TOP TRAILER.**
- **AN ADDITIONAL CHARGE WILL BE INCURRED IF A OPEN TOP OR FLAT BED TRAILER IS REQUIRED.**
- **ALL EXTENDED PIPING, WIRING OR OTHER THAN LISTED ABOVE IS PERFORMED BY OTHERS.**
- **WEATHER PROTECTIVE ENCLOSURES ARE MANUFACTURED FOR STATIONARY USE ONLY. WEATHER PROOF ENCLOSURES ARE SUITABLE FOR STATIONARY OR MOBILE (TRAILER MOUNTING) APPLICATION.**
- **UNITS ARE SHIPPED WET TO INCLUDE LUBE OIL AND A 50/50 WATER AND ANTI-FREEZE MIX UNLESS OTHERWISE NOTED IN THIS QUOTATION.**
- **SELLER IS NOT QUOTING UNIT INSTALLATION UNLESS SPECIFICALLY NOTED IN QUOTE.**

PAYMENT TERMS:

- **90% OF JOB TOTAL 15 DAYS AFTER INVOICE IS RECEIVED AND BEFORE START-UP IS PERFORMED.**
- **W. W. WILLIAMS WILL MAKE EVERY EFFORT TO INVOICE BY THE 25TH ON THE MONTH TO ENABLE THE CONTRACTOR TO SUBMIT FOR DRAW.**
- **IF EQUIPMENT IS RECEIVED AT W. W. WILLIAMS, YOU WILL BE INVOICED WHEN RECEIVED.**
- **W. W. WILLIAMS WILL HOLD EQUIPMENT AT ITS INSURED FACILITY IN STORAGE AT NO-CHARGE PENDING DELIVERY.**
- **PRICES DO NOT INCLUDE FEDERAL, STATE OR LOCAL TAXES WHICH MAY BE APPLICABLE.**
- **QUOTED PRICES INCLUDE NORMAL TESTING, PACKAGING AND INSTRUCTIONAL LITERATURE. SPECIAL TESTING, PACKAGING, ADDITIONAL INSTRUCTIONAL LITERATURE, PARTS, PROVISIONING LISTS OR PRINTS ARE NOT INCLUDED, AND PRICES WILL BE QUOTED SEPARATELY.**

SERVICE AGREEMENTS:

- **W. W. WILLIAMS OFFERS COMPREHENSIVE SCHEDULED MAINTENANCE PROGRAM AGREEMENTS (SMPA) PERFORMED BY OUR EXPERIENCED FIELD SERVICE TECHNICIANS FOR ALL MAKES OF EMERGENCY POWER SYSTEMS. A CUSTOM “SMPA” TAILORED TO MEET YOUR FACILITIES REQUIREMENTS WILL BE QUOTED ON REQUEST.**

OTHER CONDITIONS:

- **THIS PROPOSAL REPRESENTS OUR UNDERSTANDING OF THE PROJECT REQUIREMENTS. PLEASE VERIFY THAT IT MEETS THE SPECIFICATION. WE RESERVE THE RIGHT TO CORRECT ERRORS OR OMISSIONS.**
- **ALL PRICES ARE EFFECTIVE FOR THIRTY (30) DAYS UNLESS OTHERWISE INDICATED.**

Customer Acceptance:

Date: _____

Company: _____

By: _____

Title: _____

Michael D. Peters
Onsite Energy Territory Manager



COPY

TERMS AND CONDITIONS

TERMS EXCLUSIVE: This document, together with the agreements, if any, specified herein, and including the terms and conditions on the reverse hereof, constitutes the complete, exclusive and final agreement of the Buyer identified herein ("Buyer") and W. W. Williams ("Seller") and may not be added to, modified, superseded or altered except by written agreement or modification signed by Seller's authorized representative, notwithstanding any other additional or modifying terms or conditions which may now or in the future appear on Buyer's acknowledgment or other forms (all of which are objected to by Seller without future notification), and notwithstanding any shipments, tenders of delivery, acceptance of payments, or other similar acts of Seller. Buyer's acceptance of any performance by Seller shall be taken as Buyer's acceptance of these terms and conditions. NO PERSON (EXCEPT AN OFFICER OF SELLER) IS AUTHORIZED TO BIND SELLER TO ANY ORDER EXCEPT ACCORDING TO THE TERMS AND CONDITIONS ON BOTH SIDES HEREOF.

DELIVERY: Unless otherwise specified herein, delivery of the goods, and services, if any, specified herein ("Goods") shall be F.O.B. point of shipment. Any delivery date specified herein is approximate only. Acceptance of shipment by a common carrier shall constitute tender of delivery. Upon tender of delivery, risk of loss shall pass to Buyer, subject to Seller's right of stoppage in transit and to any interest of Seller reserved to secure Buyer's payment or performance. Title shall pass to Buyer when the full price has been paid. Partial shipments may be made and payments therefore shall become due in accordance with the terms hereof as shipments are made and invoices rendered.

CASUALTY AND AVAILABILITY OF SUPPLIES: Delivery of all or any part of the Goods is contingent upon Seller's ability to obtain goods (including the Goods), supplies, raw materials and services through its regular and usual sources of supply. If by reason of any contingency beyond Seller's control, including (but not limited to) war, governmental requests, restrictions or regulations, fire, flood, casualty, accident, or other acts of God, strikes or other difficulties with employees, delay or inability to obtain goods (including the Goods), labor, equipment, material and service through Seller's usual sources, failure or refusal of any carrier to transport materials, delay in transport thereof, or any other similar occurrence, Seller is not able to meet anticipated deliveries, Seller shall not be liable therefore and may, in its discretion without prior notice to Buyer, postpone the delivery date(s) under this document for a time which is reasonable under all the circumstances. Receipt of the Goods shall constitute a waiver of all claims for damages.

PAYMENT, SECURITY INTEREST: The terms of sale are subject to Seller's approval and Seller may at any time modify the terms of payment originally specified. If there is no specific contrary agreement upon terms of payment stated on the front hereof, payment shall be due and payable in one installment upon delivery. Any payment not made to Seller when due shall be subject to a carrying charge of one and one half percent (1 1/2%) per month on the unpaid balance until paid. Buyer shall have no right to offset any amount whatsoever against any payment or other obligation which Buyer may owe to Seller under this Order. Seller reserves a security interest in the Goods to secure Buyer's payment of the purchase price and any other charges owed by Buyer, and Buyer agrees that Seller may (but is not obligated to) take such action as Seller deems advisable to evidence and perfect such interest.

LIMITED WARRANTY, WARRANTY DISCLAIMERS AND LIMITATIONS OF REMEDIES AND LIABILITIES: Seller hereby assigns to Buyer any and all warranties which are made by the manufacturers and suppliers with respect to the Goods and which are assignable, but Seller makes NO REPRESENTATIONS as to the effectiveness or extent of such warranties and assumes NO RESPONSIBILITY for any matters which may be warranted by such manufacturers or suppliers. Seller makes NO OTHER WARRANTIES concerning the goods whatsoever. ON BEHALF OF ITSELF AND THE MANUFACTURERS OF THE GOODS SOLD HEREBY, SELLER DISCLAIMS AND EXCLUDES ALL OTHER WARRANTIES, EXPRESS AND IMPLIED, INCLUDING WITHOUT LIMITATION THE IMPLIED WARRANTIES OF MERCHANTABILITY AND FITNESS FOR A PARTICULAR PURPOSE. Buyer acknowledges and agrees that Seller's obligation described in this Paragraph is the sole remedy bargained for by Buyer IN LIEU OF ALL OTHER EXPRESS AND IMPLIED WARRANTIES. Buyer agrees that NO OTHER REMEDY SHALL BE AVAILABLE to Buyer and that IN NO EVENT SHALL SELLER OR ANY MANUFACTURER OF THE GOODS BE LIABLE FOR ANY INCIDENTAL OR CONSEQUENTIAL DAMAGES, including without limitation loss of income, loss of time, loss of sales, cost or replacement items, claims asserted by Buyer's customers, injury to personal property, or injury to any person, whether or not occasioned by Seller's negligence.

PRICES: All prices of the Goods are subject to change or withdrawal without notice. Unless otherwise stated by Seller, prices and pricing policies will be those set forth in Seller's published price lists or Seller's pricing policies in effect at time of shipment. In the event Buyer's order is changed in any respect (if and when permitted by Seller), Seller may adjust the price accordingly. Unless otherwise specified herein, prices are exclusive of applicable taxes, excises, duties, quotation fees or other governmental impositions which Seller may be required to pay or collect under any existing or future law and any such applicable taxes, etc., shall be paid by and/or for the account of Buyer.

CANCELLATION: Seller may cancel or terminate all or part of the contract arising from or evidenced by this document immediately upon the happening of any of the following: Buyer's material delinquency of any of its obligations hereunder or with respect to any other order or transaction with Seller; the insolvency of Buyer; the appointment of a receiver under Title 11 U.S.C., as amended (the "Bankruptcy Code"), or the commencement of a case under any chapter of the Bankruptcy Code for, by or against Buyer; Buyer's suspension or termination of business or assignment for the benefit of creditors; or any event, whether or not similar to the foregoing, which in Seller's good faith belief materially impairs the prospect of payment or performance by Buyer hereunder. Seller's rights to cancel or terminate set forth herein may be exercised by Seller without liability.

COMPLIANCE WITH LAWS/REGULATIONS/CODES: Seller makes no warranties or representation regarding emissions compliance of the Goods offered or sold hereunder. NOTWITHSTANDING ANY PROVISION IN ANY OTHER DOCUMENT TO THE CONTRARY, Seller shall not be responsible for compliance with or costs and penalties related to emissions- or code-related permits, requirements or standards related to the use and sale of the Goods offered or sold hereunder, EXCEPT where the final agreement between the parties contains a specific provision and agreement about emissions requirements. Equipment needed to meet any non-federal requirements has not been included unless specifically indicated herein.

MISCELLANEOUS: All sales are subject to acceptance by Seller. Orders entered on Seller's books cannot be changed nor deliveries deferred except with Seller's written consent and upon terms that will indemnify Seller against all loss. The contract arising hereunder will be governed by the laws of the State of Ohio. If any of the provisions hereof shall be held invalid, illegal or unenforceable, the validity, legality and enforceability of the remaining provisions shall in no way be affected or impaired thereby. No right or interest in the contract arising from this document shall be assigned by Buyer and no delegation of any obligation owed by Buyer shall be made without the prior written permission of Seller. The individual rights and remedies of Seller reserved herein shall be cumulative and additional to any other or further remedies provided in law or equity. Waiver by Seller of performance or inaction with respect to Buyer's breach of any provision hereof, or failure of Seller to enforce any provision hereof which may establish a defense or limitation of liability, shall not be deemed a waiver of future compliance therewith or a course of performance modifying such provision, and such provision shall remain in full force and effect as written.

GAS ENGINE-GENERATOR SET NATURALLY ASPIRATED

75 kWe / 60 Hz / Standby
208 - 600V



SYSTEM RATINGS

Standby (NG) (LP)	GS75N6SDN GS75L6SDN	GS75N6SGN GS75L6SGN	GS75N6SPN GS75L6SPN	GS75N6SJN GS75L6SJN	GS75N6SRN GS75L6SRN	GS75N6SNN GS75L6SNN
Voltage (L-L)	240V**	240V**	208V**	240V**	480V**	600V**
Phase	1	1	3	3	3	3
PF	1	1	0.8	0.8	0.8	0.8
Hz	60	60	60	60	60	60
Natural Gas Ratings: Amps	292	292	243	210	105	84
Natural Gas Ratings: kW/kVA	70/70	70/70	70/87.5	70/87.5	70/87.5	70/87.5
LP Gas Ratings: Amps	313	313	260	226	113	90
LP Gas Ratings: kW/kVA skVA@30%	75/75	75/75	75/93.75	75/93.75	75/93.75	75/93.75
Voltage Dip	311	107	235	235	235	235
Generator Model	363CSL1617	431CSL6202	362CSL1604	362CSL1604	362CSL1604	362PSL1635
Temp Rise	130 °C/40 °C	130 °C/40 °C	130 °C/40 °C	130 °C/40 °C	130 °C/40 °C	130 °C/40 °C
Connection	4 LEAD	12 LEAD ZIG-ZAG	12 LEAD LOW WYE	12 LEAD HI DELTA	12 LEAD HI WYE	4 LEAD WYE

** UL 2200 Offered

Note: This unit is available with a dual fuel configuration.

CERTIFICATIONS AND STANDARDS

// **Engine-generator set is designed and manufactured in facilities certified to standards ISO 9001:2008 and ISO 14001:2004**

// **Power Rating**

- Accepts Rated Load in One Step Per NFPA 110

// **UL 2200 / CSA - Optional**

- UL 2200 Listed
- CSA Certified

// **Performance Assurance Certification (PAC)**

- Engine-Generator Set Tested to ISO 8528-5 for Transient Response
- Verified product design, quality and performance integrity
- All engine systems are prototype and factory tested



STANDARD FEATURES*

- // MTU Onsite Energy is a single source supplier
 - // Global Product Support
 - // 2 Year Standard Warranty
 - // 6.8L Engine
 - 6.8 Liter Displacement
 - 4-Cycle
 - // Optional Fuels: LP Liquid and Dual Fuel
 - // Engine-generator resilient mounted
 - // Complete Range of Accessories
- // Generator
 - Brushless, Rotating Field Generator
 - 2/3 Pitch Windings
 - 300% Short Circuit Capability
 - // Digital Control Panel
 - UL Recognized, CSA Certified, NFPA 110
 - Complete System Metering
 - LCD Display
 - // Cooling System
 - Integral Set-Mounted
 - Engine Driven Fan

STANDARD EQUIPMENT*

// Engine

Heavy Duty Air Cleaner
 Oil Pump
 Oil Drain Extension & S/O Valve
 Full Flow Oil Filter
 Jacket Water Pump
 Thermostat
 Blower Fan & Fan Drive
 Radiator - Unit Mounted
 Electric Starting Motor - 12V
 Governor - Electronic Isochronous
 Base - Formed Steel
 SAE Flywheel & Bell Housing
 Charging Alternator - 12V
 Battery Rack & Cables
 Flexible Exhaust Connection
 EPA Certified Engine

// Generator

NEMA MG1, IEEE and ANSI standards compliance for temperature rise and motor starting
 Sustained short circuit current of up to 300% of the rated current for up to 10 seconds
 Self-Ventilated
 Superior Voltage Waveform
 Solid State, Volts-per-Hertz Regulator
 ±1% Voltage Regulation No Load to Full Load Regulation

Brushless Alternator with Brushless Pilot Exciter
 4 Pole, Rotating Field
 130 °C Maximum Standby Temperature Rise
 1 Bearing, Sealed
 Flexible Coupling
 Full Amortisseur Windings
 125% Rotor Balancing
 3-Phase Voltage Sensing
 100% of Rated Load - One Step
 3% Maximum Harmonic Content

// Digital Control Panel(s)

Digital Metering
 Engine Parameters
 Generator Protection Functions
 Engine Protection
 SAE J1939 Engine ECU Communications
 Windows-Based Software
 Multilingual Capability
 Remote Communications to RDP-110 Remote Annunciator
 16 Programmable Contact Inputs
 Up to 11 Contact Outputs
 UL Recognized, CSA Certified, CE Approved
 Event Recording
 IP 54 Front Panel Rating with Integrated Gasket
 NFPA110 Compatible

* Represents standard product only. Consult Factory/MTU Onsite Energy Distributor for additional configurations.



APPLICATION DATA

// Engine

Manufacturer	Ford
Model	6.8L V10
Type	4-Cycle
Aspiration	Naturally Aspirated
Arrangement	10-V
Displacement: L (in ³)	6.8 (415)
Bore: cm (in)	90.2 (3.55)
Stroke: cm (in)	105.8 (4.17)
Compression Ratio	9:1
Rated RPM	1,800
Engine Governor	Bosch
Maximum Power (NG): kWm (bhp)	85.6 (114.8)
Maximum Power (LP): kWm (bhp)	89.4 (119.9)
Speed Regulation	C/F
Air Cleaner	Dry

// Liquid Capacity (Lubrication)

Total Oil System: L (gal)	5.7 (1.5)
Engine Jacket Water Capacity: L (gal)	5.9 (1.55)
System Coolant Capacity: L (gal)	25.58 (6.75)

// Electrical

Electric Volts DC	12
Cold Cranking Amps Under -17.8 °C (0 °F)	750

// Fuel Inlet

Fuel Supply Connection Size	1 1/2" NPT
Fuel Supply Pressure: mm H ₂ O (in. H ₂ O)	178-279 (7-11)

// Fuel Consumption (NG-1000 BTU/ft³ / LP-2500 BTU/ft³)

	NG	LPG
At 100% of Power Rating: m ³ /hr (ft ³ /hr)	27.2 (960)	11.4 (403)
At 75% of Power Rating: m ³ /hr (ft ³ /hr)	21.5 (759)	9.3 (328)
At 50% of Power Rating: m ³ /hr (ft ³ /hr)	15.6 (551)	6.8 (239)

// Cooling - Radiator System

Ambient Capacity of Radiator: °C (°F)	50 (122)
Maximum Restriction of Cooling Air, Intake, and Discharge Side of Rad.: kPa (in. H ₂ O)	0.12 (0.5)
Water Pump Capacity: L/min (gpm)	123 (32.5)
Heat Rejection to Coolant: kW (BTUM)	78.2 (4,448)
Heat Radiated to Ambient: kW (BTUM)	19.1 (1,086)

// Air Requirements

Aspirating: *m ³ /min (SCFM)	4.54 (160.5)
Air Flow Required for Rad.	
Cooled Unit: *m ³ /min (SCFM)	303.4 (10,715)
Remote Cooled Applications; Air Flow Required for Dissipation of Radiated Gen-set Heat For a Max of 25 °F Rise: *m ³ /min (SCFM)	103 (3,369)

* Air density = 1.184 kg/m³ (0.0739 lbm/ft³)

// Exhaust System

Gas Temp. (Stack): °C (°F)	660 (1,220)
Gas Volume at Stack Temp: m ³ /min (CFM)	15.3 (539)
Maximum Allowable Back Pressure: kPa (in. H ₂ O)	4.98 (20)



WEIGHTS AND DIMENSIONS

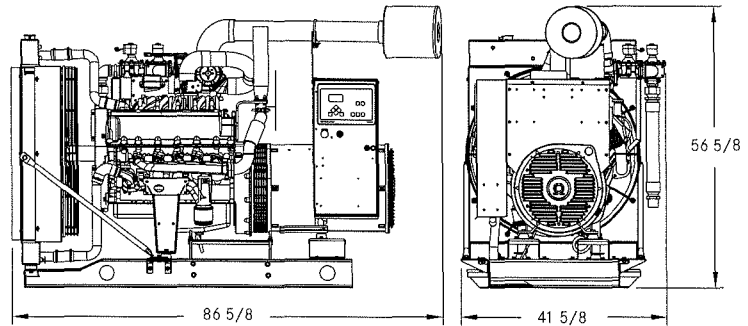

Drawing above for illustration purposes only, based on standard open power 480 volt engine-generator set. Lengths may vary with other voltages. Do not use for installation design. See website for unit specific template drawings.

System	Dimensions (LxWxH)	Weight (dry)
OPU	2,199 x 1,438 x 1,057 mm (86.6 x 56.6 x 41.6 in)	1,125 kg (2,481 lb)

Weights and dimensions are based on open power units and are estimates only. Consult the factory for accurate weights and dimensions for your specific engine-generator set.

SOUND DATA

Unit Type	Standby Full Load (NG)	Standby Full Load (LP)
Level 0: Open Power Unit (dBA)	75.5	76.1

Sound data is provided at 7 m (23 ft). Engine-generator set tested in accordance with ISO 8528-10 and with infinite exhaust.

EMISSIONS DATA

Fuel Type	THC + NO	CO
Natural Gas	7.5	30.5
Liquid Propane	7.6	47.8

All units are in g/hp-hr.

Engine meets EPA 40 CFR Part 60/90 specifications.

RATING DEFINITIONS AND CONDITIONS

// Standby ratings apply to installations served by a reliable utility source. The standby rating is applicable to varying loads for the duration of a power outage. No overload capability for this rating. Ratings are in accordance with ISO 3046-1, BS 5514, AS 2789, and DIN 6271.

// Deration Factor:

Altitude: Consult your local MTU Onsite Energy Power Generation Distributor for altitude derations.

Temperature: Consult your local MTU Onsite Energy Power Generation Distributor for temperature derations.

Materials and specifications subject to change without notice.

C/F = Consult Factory/MTU Onsite Energy Distributor

// **Tognum Group Companies: Europe / Middle East / Africa** / MTU Onsite Energy / 88040 Friedrichshafen / Germany / Phone + 49 7541 90 7060 / Fax +49 7541 90 7084 / powergenregion1@mtu-online.com // **Asia / Australia / Pacific** / MTU Onsite Energy / 1, Benoi Place / Singapore 629923 / Republic of Singapore / Phone + 65 6861 5922 / Fax + 65 6861 3615 / powergenregion2@mtu-online.com // **USA / Canada / Latin America / Mexico** / MTU Onsite Energy Corporation / 100 Power Drive / Mankato, Minnesota 56001 / USA / Phone + 1 507 625 7973 / Fax + 1 507 625 2968 / powergenregion3@mtu-online.com

GAS ENGINE-GENERATOR SET SOUND DATA

GS75-6S
60 Hz



ENCLOSURE LEVEL IDENTIFICATION

Level 0: Open Powered Unit. No enclosure.

Level 1: Weather proof enclosure constructed of heavy gauge steel or aluminum with fixed storm proof panels designed for 150 mph wind load rating. Enclosure consists of a bolted construction with pre-mounted internal muffler. Double-door access on both sides of the enclosure. Hinged, lockable doors.

Level 2: Level 1 enclosure with sound attenuated foam installed inside enclosure walls.

Level 3: Level 1 enclosure with air exhaust scoop and sound attenuated foam installed in scoop.

SOUND RATINGS dB(A) at 7 meters.

Enclosure Level	// Natural Gas (NG)	// Liquid Propane (LP)
	Standby (70 kW)	Standby (75 kW)
Level 0	75.5	76.1
Level 1	73	73.3
Level 2	71.8	72
Level 3	67.8	68.1
Level 3 w/ Foam in Housing*	61.5	61.6

- NOTE:**
- Sound pressure levels subject to instrumentation, measurement, installation and engine-generator set variability
 - Sound power levels per ISO 8528 and ANSI S1.13-2005
 - Sound data measured with:
 - full-rated load
 - standard radiator package
 - 14 gauge steel enclosures
 - infinite exhaust connection

COPY

* Option available for additional sound attenuation.

AIA[®] Document A310[™] – 2010

Bid Bond

CONTRACTOR:

(Name, legal status and address)

W.W. Williams Midwest, Inc.
835 West Goodale Blvd.
Columbus, OH 43212

SURETY:

(Name, legal status and principal place of business)

Liberty Mutual Insurance Company
8044 Montgomery Rd., Ste 150E
Cincinnati, OH 45236

OWNER:

(Name, legal status and address)

City of Novi
45175 W. Ten Mile Road
Novi, MI 48375-3024

BOND AMOUNT:

Five Percent of the Total Amount Bid ----- (\$*** 5 % TAB ***)

PROJECT:

(Name, location or address, and Project number, if any)

Lift Station Generator (Supply & Install)

This document has important legal consequences. Consultation with an attorney is encouraged with respect to its completion or modification.

Any singular reference to Contractor, Surety, Owner or other party shall be considered plural where applicable.

The Contractor and Surety are bound to the Owner in the amount set forth above, for the payment of which the Contractor and Surety bind themselves, their heirs, executors, administrators, successors and assigns, jointly and severally, as provided herein. The conditions of this Bond are such that if the Owner accepts the bid of the Contractor within the time specified in the bid documents, or within such time period as may be agreed to by the Owner and Contractor, and the Contractor either (1) enters into a contract with the Owner in accordance with the terms of such bid, and gives such bond or bonds as may be specified in the bidding or Contract Documents, with a surety admitted in the jurisdiction of the Project and otherwise acceptable to the Owner, for the faithful performance of such Contract and for the prompt payment of labor and material furnished in the prosecution thereof; or (2) pays to the Owner the difference, not to exceed the amount of this Bond, between the amount specified in said bid and such larger amount for which the Owner may in good faith contract with another party to perform the work covered by said bid, then this obligation shall be null and void, otherwise to remain in full force and effect. The Surety hereby waives any notice of an agreement between the Owner and Contractor to extend the time in which the Owner may accept the bid. Waiver of notice by the Surety shall not apply to any extension exceeding sixty (60) days in the aggregate beyond the time for acceptance of bids specified in the bid documents, and the Owner and Contractor shall obtain the Surety's consent for an extension beyond sixty (60) days.

If this Bond is issued in connection with a subcontractor's bid to a Contractor, the term Contractor in this Bond shall be deemed to be Subcontractor and the term Owner shall be deemed to be Contractor.

When this Bond has been furnished to comply with a statutory or other legal requirement in the location of the Project, any provision in this Bond conflicting with said statutory or legal requirement shall be deemed deleted herefrom and provisions conforming to such statutory or other legal requirement shall be deemed incorporated herein. When so furnished, the intent is that this Bond shall be construed as a statutory bond and not as a common law bond.

Signed and sealed this 5th day of December, 2012.



(Witness)

(Witness)

W. W. Williams Midwest, Inc.

(Principal)  (Seal)

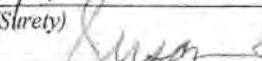
(Title) Janet D. Gibson, Secretary & General Counsel
Liberty Mutual Insurance Company

(Surety)  (Seal)

(Title) Susan E. Hurd, Attorney-in-Fact

CAUTION: You should sign an original AIA Contract Document, on which this text appears in RED. An original assures that changes will not be obscured.

Int.

AIA Document A310[™] – 2010. Copyright © 1963, 1970 and 2010 by The American Institute of Architects. All rights reserved. WARNING: This AIA[®] Document is protected by U.S. Copyright Law and International Treaties. Unauthorized reproduction or distribution of this AIA[®] Document, or any portion of it, may result in severe civil and criminal penalties, and will be prosecuted to the maximum extent possible under the law. Purchasers are permitted to reproduce ten (10) copies of this document when completed. To report copyright violations of AIA Contract Documents, e-mail The American Institute of Architects' legal counsel, copyright@aia.org

COPY

THIS POWER OF ATTORNEY IS NOT VALID UNLESS IT IS PRINTED ON RED BACKGROUND.

5208090

This Power of Attorney limits the acts of those named herein, and they have no authority to bind the Company except in the manner and to the extent herein stated.

Certificate No. _____

American Fire and Casualty Company
The Ohio Casualty Insurance Company
West American Insurance Company

Liberty Mutual Insurance Company
Peerless Insurance Company

POWER OF ATTORNEY

KNOWN ALL PERSONS BY THESE PRESENTS: That American Fire & Casualty Company and The Ohio Casualty Insurance Company are corporations duly organized under the laws of the State of Ohio, that Liberty Mutual Insurance Company is a corporation duly organized under the laws of the State of Massachusetts, that Peerless Insurance Company is a corporation duly organized under the laws of the State of New Hampshire, and West American Insurance Company is a corporation duly organized under the laws of the State of Indiana (herein collectively called the "Companies"), pursuant to and by authority herein set forth, does hereby name, constitute and appoint, **ROBERT B. ROBINSON, SUSAN E. HURD, CRAIG S. MARKOS, DEBRA J. FISCHER, STEPHEN J. FEDERER, NANCY S. TARINI ALL OF THE CITY OF DUBLIN, STATE OF OHIO AND SUSAN A. DIEHR,**.....

all of the city of TOLEDO, state of OHIO each individually if there be more than one named, its true and lawful attorney-in-fact to make, execute, seal, acknowledge and deliver, for and on its behalf as surety and as its act and deed, any and all undertakings, bonds, recognizances and other surety obligations, in pursuance of these presents and shall be as binding upon the Companies as if they have been duly signed by the president and attested by the secretary of the Companies in their own proper persons.

IN WITNESS WHEREOF, this Power of Attorney has been subscribed by an authorized officer or official of the Companies and the corporate seals of the Companies have been affixed thereto this 1st day of March, 2012.



American Fire and Casualty Company
The Ohio Casualty Insurance Company
Liberty Mutual Insurance Company
Peerless Insurance Company
West American Insurance Company

By: *Gregory W. Davenport*
Gregory W. Davenport, Assistant Secretary

STATE OF WASHINGTON SS
COUNTY OF KING

On this 1st day of March, 2012, before me personally appeared Gregory W. Davenport, who acknowledged himself to be the Assistant Secretary of American Fire and Casualty Company, Liberty Mutual Insurance Company, The Ohio Casualty Company, Peerless Insurance Company and West American Insurance Company, and that he, as such, being authorized so to do, execute the foregoing instrument for the purposes therein contained by signing on behalf of the corporations by himself as a duly authorized officer.

IN WITNESS WHEREOF, I have hereunto subscribed my name and affixed my notarial seal at Seattle, Washington, on the day and year first above written.



By: *KD Riley*
KD Riley, Notary Public

This Power of Attorney is made and executed pursuant to and by authority of the following By-laws and Authorizations of American Fire and Casualty Company, The Ohio Casualty Insurance Company, Liberty Mutual Insurance Company, West American Insurance Company and Peerless Insurance Company, which resolutions are now in full force and effect reading as follows:

ARTICLE IV – OFFICERS – Section 12. Power of Attorney. Any officer or other official of the Corporation authorized for that purpose in writing by the Chairman or the President, and subject to such limitation as the Chairman or the President may prescribe, shall appoint such attorneys-in-fact, as may be necessary to act in behalf of the Corporation to make, execute, seal, acknowledge and deliver as surety any and all undertakings, bonds, recognizances and other surety obligations. Such attorneys-in-fact, subject to the limitations set forth in their respective powers of attorney, shall have full power to bind the Corporation by their signature and execution of any such instruments and to attach thereto the seal of the Corporation. When so executed, such instruments shall be as binding as if signed by the President and attested to by the Secretary. Any power or authority granted to any representative or attorney-in-fact under the provisions of this article may be revoked at any time by the Board, the Chairman, the President or by the officer or officers granting such power or authority.

ARTICLE XIII – Execution of Contracts – SECTION 5. Surety Bonds and Undertakings. Any officer of the Company authorized for that purpose in writing by the chairman or the president, and subject to such limitations as the chairman or the president may prescribe, shall appoint such attorneys-in-fact, as may be necessary to act in behalf of the Company to make, execute, seal, acknowledge and deliver as surety any and all undertakings, bonds, recognizances and other surety obligations. Such attorneys-in-fact subject to the limitations set forth in their respective powers of attorney, shall have full power to bind the Company by their signature and execution of any such instruments and to attach thereto the seal of the Company. When so executed such instruments shall be as binding as if signed by the president and attested by the secretary.

Certificate of Designation – The President of the Company, acting pursuant to the Bylaws of the Company, authorizes Gregory W. Davenport, Assistant Secretary to appoint such attorney-in-fact as may be necessary to act on behalf of the Company to make, execute, seal, acknowledge and deliver as surety any and all undertakings, bonds, recognizances and other surety obligations.

Authorization – By unanimous consent of the Company's Board of Directors, the Company consents that facsimile or mechanically reproduced signature of any assistant secretary of the Company, wherever appearing upon a certified copy of any power of attorney issued by the Company in connection with surety bonds, shall be valid and binding upon the Company with the same force and effect as though manually affixed.

I, David M. Carey, the undersigned, Assistant Secretary, of American Fire and Casualty Company, The Ohio Casualty Insurance Company, Liberty Mutual Insurance Company, West American Insurance Company and Peerless Insurance Company do hereby certify that the original power of attorney of which the foregoing is a full above and foregoing is a true and correct copy of the Power of Attorney executed by said Companies, which is in full force and effect and has not been revoked.

IN TESTIMONY WHEREOF, I have hereunto set my hand and affixed the seals of said Companies this 5th day of December, 2012.



By: *David M. Carey*
David M. Carey, Assistant Secretary

COPY

Not valid for mortgage, note, loan, letter of credit, bank deposit, currency rate, interest rate or residual value guarantees.

To confirm the validity of this Power of Attorney call 1-610-832-8240 between 9:00 am and 4:30 pm EST on any business day.



LIBERTY MUTUAL INSURANCE COMPANY
 FINANCIAL STATEMENT — DECEMBER 31, 2011

Assets		Liabilities	
Cash and Bank Deposits.....	\$ 696,606,839	Unearned Premiums.....	\$3,762,485,913
*Bonds — U.S Government.....	910,151,865	Reserve for Claims and Claims Expense	15,817,904,502
*Other Bonds.....	11,794,792,561	Funds Held Under Reinsurance Treaties.....	1,249,980,610
*Stocks	8,216,137,875	Reserve for Dividends to Policyholders.....	4,656,284
Real Estate.....	268,420,606	Additional Statutory Reserve.....	77,791,575
Agents' Balances or Uncollected Premiums.....	3,191,269,641	Reserve for Commissions, Taxes and	
Accrued Interest and Rents.....	151,164,670	Other Liabilities	<u>2,885,589,205</u>
Other Admitted Assets.....	<u>12,166,299,092</u>	Total	\$23,798,408,089
Total Admitted Assets	<u>\$37,394,843,149</u>	Special Surplus Funds.....	\$1,036,917,657
		Capital Stock.....	10,000,000
		Paid in Surplus	7,732,061,653
		Unassigned Surplus.....	4,817,455,750
		Surplus to Policyholders	<u>13,596,435,060</u>
		Total Liabilities and Surplus	<u>\$37,394,843,149</u>



* Bonds are stated at amortized or investment value; Stocks at Association Market Values.
 The foregoing financial information is taken from Liberty Mutual Insurance Company's financial statement filed with the state of Massachusetts Department of Insurance.

I, TIM MIKOLAJEWSKI, Assistant Secretary of Liberty Mutual Insurance Company, do hereby certify that the foregoing is a true, and correct statement of the Assets and Liabilities of said Corporation, as of December 31, 2011, to the best of my knowledge and belief.

IN WITNESS WHEREOF, I have hereunto set my hand and affixed the seal of said Corporation at Seattle, Washington, this 5th day of April, 2012.

T. Mikolajewski

Assistant Secretary



Office of Financial
Regulation Services
50 West Town Street
Third Floor- Suite 300
Columbus, Ohio 43215
(614) 644-2658
Fax (614) 644-3256
www.ohioinsurance.gov

Ohio Department of Insurance

John R. Kasich - Governor
Mary Taylor - Lt. Governor/Director

Certificate of Compliance



Issued	03/27/12
Effective	04/02/12
Expires	04/01/13

I, Mary Taylor, hereby certify that I am the Lt. Governor/Director of Insurance in the State of Ohio and have supervision of insurance business in said State and as such I hereby certify that

LIBERTY MUTUAL INSURANCE COMPANY

is authorized to transact the business of insurance under the following section(s) of the Ohio Revised Code:

Section 3929.01 (A)

Accident & Health	Inland Marine
Aircraft	Medical Malpractice
Allied Lines	Multiple Peril - Commercial
Boiler & Machinery	Multiple Peril - Farmowners
Burglary & Theft	Multiple Peril - Homeowners
Collectively Renewable A & H	Noncancellable A & H
Commercial Auto - Liability Other	Nonrenew - State Reasons (A&H)
Commercial Auto - No Fault	Ocean Marine
Commercial Auto - Phys. Damage	Other Accident only
Credit	Other Liability
Credit Accident & Health	Private Passenger Auto - No Fault
Earthquake	Private Passenger Auto-Liability Other
Fidelity	Private Passenger-Phys Damage
Financial Guaranty	Surety
Fire	Workers Compensation
Glass	
Group Accident & Health	
Guaranteed Renewable A & H	

LIBERTY MUTUAL INSURANCE COMPANY certified in its annual statement to this Department as of December 31, 2011 that it has admitted assets in the amount of \$37,394,843,149, liabilities in the amount of \$23,798,408,089, and surplus of at least \$13,596,435,060.

IN WITNESS WHEREOF, I have hereunto subscribed my name and caused my seal to be affixed at Columbus, Ohio, this day and date.

Mary Taylor

Mary Taylor
Lt. Governor/Director





CERTIFICATE OF LIABILITY INSURANCE

DATE (MM/DD/YYYY)
12/3/2012

THIS CERTIFICATE IS ISSUED AS A MATTER OF INFORMATION ONLY AND CONFERS NO RIGHTS UPON THE CERTIFICATE HOLDER. THIS CERTIFICATE DOES NOT AFFIRMATIVELY OR NEGATIVELY AMEND, EXTEND OR ALTER THE COVERAGE AFFORDED BY THE POLICIES BELOW. THIS CERTIFICATE OF INSURANCE DOES NOT CONSTITUTE A CONTRACT BETWEEN THE ISSUING INSURER(S), AUTHORIZED REPRESENTATIVE OR PRODUCER, AND THE CERTIFICATE HOLDER.

IMPORTANT: If the certificate holder is an ADDITIONAL INSURED, the policy(ies) must be endorsed. If SUBROGATION IS WAIVED, subject to the terms and conditions of the policy, certain policies may require an endorsement. A statement on this certificate does not confer rights to the certificate holder in lieu of such endorsement(s).

PRODUCER Hylant Group - Columbus 565 Metro Place South, Suite 450 Dublin, OH 43017	CONTACT NAME:		
	PHONE (A/C, No, Ext):	614-932-1200	FAX (A/C, No): 614-932-1299
E-MAIL ADDRESS:			
INSURER(S) AFFORDING COVERAGE			NAIC #
INSURER A : Travelers Prop & Cas Co of America			25674
INSURER B : Great American Insurance Co.			16691
INSURER C :			
INSURER D :			
INSURER E :			
INSURER F :			

INSURED
The W.W. Williams Company
See Below for Additional Named Insured
835 West Goodale Blvd
Columbus, OH 43212

COVERAGES CERTIFICATE NUMBER: REVISION NUMBER:

THIS IS TO CERTIFY THAT THE POLICIES OF INSURANCE LISTED BELOW HAVE BEEN ISSUED TO THE INSURED NAMED ABOVE FOR THE POLICY PERIOD INDICATED. NOTWITHSTANDING ANY REQUIREMENT, TERM OR CONDITION OF ANY CONTRACT OR OTHER DOCUMENT WITH RESPECT TO WHICH THIS CERTIFICATE MAY BE ISSUED OR MAY PERTAIN, THE INSURANCE AFFORDED BY THE POLICIES DESCRIBED HEREIN IS SUBJECT TO ALL THE TERMS, EXCLUSIONS AND CONDITIONS OF SUCH POLICIES. LIMITS SHOWN MAY HAVE BEEN REDUCED BY PAID CLAIMS.

INSR LTR	TYPE OF INSURANCE	ADDL INSR	SUBR WVD	POLICY NUMBER	POLICY EFF (MM/DD/YYYY)	POLICY EXP (MM/DD/YYYY)	LIMITS
A	<input checked="" type="checkbox"/> GENERAL LIABILITY <input checked="" type="checkbox"/> COMMERCIAL GENERAL LIABILITY <input type="checkbox"/> CLAIMS-MADE <input checked="" type="checkbox"/> OCCUR GENL AGGREGATE LIMIT APPLIES PER: <input type="checkbox"/> POLICY <input checked="" type="checkbox"/> PROJECT <input checked="" type="checkbox"/> LOC	X	X	TC2JGLSA134D691812	11/01/12	11/01/13	EACH OCCURRENCE \$ 1,000,000 DAMAGE TO RENTED PREMISES (Ea occurrence) \$ 1,000,000 MED EXP (Any one person) \$ 5,000 PERSONAL & ADV INJURY \$ 1,000,000 GENERAL AGGREGATE \$ 2,000,000 PRODUCTS - COMP/OP AGG \$ 2,000,000 \$
A	<input checked="" type="checkbox"/> AUTOMOBILE LIABILITY <input type="checkbox"/> ANY AUTO <input type="checkbox"/> ALL OWNED AUTOS <input type="checkbox"/> HIRED AUTOS <input type="checkbox"/> SCHEDULED AUTOS <input type="checkbox"/> NON-OWNED AUTOS	X	X	TC2JCAP134D692A12	11/01/12	11/01/13	COMBINED SINGLE LIMIT (Ea accident) \$ 1,000,000 BODILY INJURY (Per person) \$ BODILY INJURY (Per accident) \$ PROPERTY DAMAGE (Per accident) \$ \$
B	<input checked="" type="checkbox"/> UMBRELLA LIAB <input checked="" type="checkbox"/> OCCUR <input type="checkbox"/> EXCESS LIAB <input type="checkbox"/> CLAIMS-MADE <input type="checkbox"/> DED <input checked="" type="checkbox"/> RETENTION \$ 10,000	X		TUU357871306	11/01/12	11/01/13	EACH OCCURRENCE \$ 10,000,000 AGGREGATE \$ 10,000,000 \$
A	<input checked="" type="checkbox"/> WORKERS COMPENSATION AND EMPLOYERS' LIABILITY <input type="checkbox"/> ANY PROPRIETOR/PARTNER/EXECUTIVE OFFICER/MEMBER EXCLUDED? (Mandatory in NH) If yes, describe under DESCRIPTION OF OPERATIONS below		X	TC2HUB134D107A12 Included All Other States	11/01/12	11/01/13	<input checked="" type="checkbox"/> WC STATUTORY LIMITS <input type="checkbox"/> OTHER E.L. EACH ACCIDENT \$ 1,000,000 E.L. DISEASE - EA EMPLOYEE \$ 1,000,000 E.L. DISEASE - POLICY LIMIT \$ 1,000,000

DESCRIPTION OF OPERATIONS / LOCATIONS / VEHICLES (Attach ACORD 101, Additional Remarks Schedule, if more space is required)
Additional Named Insureds: W.W. Williams Southwest, Inc., W.W. Williams Midwest, Inc., W.W. Williams Southeast, Inc., W.W. Williams Transport Refrigeration, Inc., W.W. Williams Power Systems, Inc., W.W. Williams Logistics, LLC.

Certificate Holder is included as Additional Insured where required by written contract. Insurance is primary and non-contributory where required by contract. Named Insureds Rights of Subrogation are waived where required by written contract.

CERTIFICATE HOLDER

CANCELLATION

City of Novi City Clerk's Office 45175 W Ten Mile Road Novi MI 48375-3024	SHOULD ANY OF THE ABOVE DESCRIBED POLICIES BE CANCELLED BEFORE THE EXPIRATION DATE THEREOF, NOTICE WILL BE DELIVERED IN ACCORDANCE WITH THE POLICY PROVISIONS.
	AUTHORIZED REPRESENTATIVE <i>Patricia Dayton</i>

© 1988-2010 ACORD CORPORATION. All rights reserved.



AMERICAN GENERATOR'S BID



CITY OF NOVI
BID FORM

COPY

LIFT STATION GENERATOR

We the undersigned, as bidder, propose to furnish to the City of Novi, according to the terms, conditions, and instructions attached hereto and made a part thereof:

A. Lift Station Generator \$ 31,334.00 Lump Sum
(see comments for additional Generac option)
Make/Model Blue Star GM100-03

B. Transfer Switch (choose one)

- We are able to use the existing transfer switch.
- We are unable to use the existing transfer switch. The additional cost for a new transfer switch is \$ _____.

Delivery date 8-10 weeks ARO

Warranty: Standard 2 Years / 1500 Hours

REFERENCES: Please provide at least three client (3) references for projects of similar scope done in the last 3 years.

Company Lime Village Traditional Council
 Address P.O. Box LVD, Lime Village VIA McGrath, Alaska 99627-8999
 Phone 907.526.5236 Contact name Ursula Graham
Installed and paralleled two 12kw generators for small Alaskan Village

Company Gary Wine Residence
 Address 5087 Hickory Point Dr.
 Phone 248.770.7878 Contact name Gary Wine
Installed 100kw generator & transfer switch (Blue Star)

COPY

Company Detroit Diesel Corp.

Address P.O. Box 5936, Troy, MI 48007-5936

Phone 313.592.5006 Contact name Bryan Cicinelli

Custom Installation of 30kw generator in mobile trailer (Blue Star)

EXCEPTIONS TO SPECIFICATIONS (all exceptions must be indicated here):

COMMENTS: Additional Quote of 80kw Generac as a
second option; \$28,985 - Warranty, Two (2) years
Standard - able to use existing transfer switch - Make:
Generac Model: SG-080 - Lead Time: 6-8 weeks ARO - Spec Sheet enclosed

We acknowledge receipt of the following Addenda: #1, #2
(please indicate numbers)

THIS BID SUBMITTED BY:

Company (Legal Registration) American Generators Sales + Service LLC

Address 6158 Delfield Dr.

City Waterford State MI Zip 483

Telephone 248.623.4919 Fax 248.623.4918

Representative's Name (please print) Leah Cavalier

Representative's Title Project Manager

Representative's Signature Leah Cavalier

E-mail Lcavalier@american-generator.com

Date 12-5-12

CITY OF NOVI
LIFT STATION GENERATOR

COPY

Please return this page with your bid form

If your company is awarded the item(s) referenced in the bid proposal, other governmental entities may wish to use this contract and will issue a purchase order or contract for the item(s) awarded in the bid proposal following minimum order/contract requirements set forth in the bid documents. Each entity will provide their own purchase order and delivery location(s) and must be invoiced separately to the address indicated on their purchase order.

1. EXTENSION OF AWARD TO THE MITN (MICHIGAN INTER-GOVERNMENTAL TRADE NETWORK)
PURCHASING COOPERATIVE: **OPTIONAL**

Numerous Counties, Cities, Townships, and Authorities of the State of Michigan are members of the MITN (Michigan Inter-governmental Trade Network) Purchasing Cooperative. Other associate entities are also members of the Cooperative in the Tri-County area. Please visit www.mitn.info website to view the entire list of participating agencies.

() If an award is made to _____, it is agreed that the contract will be extended to other MITN Purchasing Cooperative members and associate entities under the same prices, terms, and conditions.

Our company is **NOT** interested in extending the contract to those MITN members listed on the website.

2. EXTENSION OF AWARD TO THE CITY OF NORTHVILLE: **OPTIONAL**

The City of Novi is working with the Novi Community School District, City of Northville, Northville Community School District and the Walled Lake Consolidated Schools to discover opportunities to optimize procurement services.

() If an award is made to _____, it is agreed that the contract will be extended to Novi Community School District, City of Northville, Northville Community School District and the Walled Lake Consolidated Schools under the same prices, terms, and conditions.

Our company is **NOT** interested in extending the contract to Novi Community School District, City of Northville, Northville Community School District and the Walled Lake Consolidated Schools under the same prices, terms, and conditions.

Contractor Signature: _____

Company Name: _____

Date: _____

BID BOND
(Percentage)

Bond No. 61535407

KNOW ALL PERSONS BY THESE PRESENTS, That we American Generators Sales and Service, LLC
of 6158 Delfield Dr., Ste. C, Waterford, MI 48329

_____, hereinafter referred to as the Principal, and
WESTERN SURETY COMPANY

as Surety, are held and firmly bound unto City of Novi

of _____, hereinafter referred to as the Oblige, in the amount of
Five Percent of the Amount Bid
(5%), for the payment of which we bind ourselves, our legal representatives,
successors and assigns, jointly and severally, firmly by these presents.

WHEREAS, Principal has submitted or is about to submit a proposal to Oblige on a contract for _____
Wixom Road Lift Station Generator

NOW, THEREFORE, if the said contract be awarded to Principal and Principal shall, within such time as may be specified, enter into the contract in writing and give such bond or bonds as may be specified in the bidding or contract documents with surety acceptable to Oblige; or if Principal shall fail to do so, pay to Oblige the damages which Oblige may suffer by reason of such failure not exceeding the penalty of this bond, then this obligation shall be void; otherwise to remain in full force and effect.

SIGNED, SEALED AND DATED this 5th day of December, 2012.

Principal

American Generators Sales and Service, LLC

BY: 

Surety

WESTERN SURETY COMPANY

BY: 

Jeanne D. Schatz, Attorney-in-Fact

Western Surety Company

POWER OF ATTORNEY - CERTIFIED COPY

Bond No. 61535407

Know All Men By These Presents, that WESTERN SURETY COMPANY, a corporation duly organized and existing under the laws of the State of South Dakota, and having its principal office in Sioux Falls, South Dakota (the "Company"), does by these presents make, constitute and appoint Jeanne D Schatz

its true and lawful attorney(s)-in-fact, with full power and authority hereby conferred, to execute, acknowledge and deliver for and on its behalf as Surety, bonds for:

Principal: American Generators Sales and Service, LLC

Obligee: City of Novi

Amount: \$500,000.00

and to bind the Company thereby as fully and to the same extent as if such bonds were signed by the Senior Vice President, sealed with the corporate seal of the Company and duly attested by its Secretary, hereby ratifying and confirming all that the said attorney(s)-in-fact may do within the above stated limitations. Said appointment is made under and by authority of the following bylaw of Western Surety Company which remains in full force and effect.

"Section 7. All bonds, policies, undertakings, Powers of Attorney or other obligations of the corporation shall be executed in the corporate name of the Company by the President, Secretary, any Assistant Secretary, Treasurer, or any Vice President or by such other officers as the Board of Directors may authorize. The President, any Vice President, Secretary, any Assistant Secretary, or the Treasurer may appoint Attorneys in Fact or agents who shall have authority to issue bonds, policies, or undertakings in the name of the Company. The corporate seal is not necessary for the validity of any bonds, policies, undertakings, Powers of Attorney or other obligations of the corporation. The signature of any such officer and the corporate seal may be printed by facsimile."

All authority hereby conferred shall expire and terminate, without notice, unless used before midnight of March 5th, 2013, but until such time shall be irrevocable and in full force and effect.

In Witness Whereof, Western Surety Company has caused these presents to be signed by its Vice President, Paul T. Bruflat, and its corporate seal to be affixed this 5th day of December, 2012.



WESTERN SURETY COMPANY

Paul T. Bruflat
Paul T. Bruflat, Vice President

On this 5th day of December, in the year 2012, before me, a notary public, personally appeared Paul T. Bruflat, who being to me duly sworn, acknowledged that he signed the above Power of Attorney as the aforesaid officer of WESTERN SURETY COMPANY and acknowledged said instrument to be the voluntary act and deed of said corporation.



S. Petrik
Notary Public - South Dakota

I the undersigned officer of Western Surety Company, a stock corporation of the State of South Dakota, do hereby certify that the attached Power of Attorney is in full force and effect and is irrevocable, and furthermore, that Section 7 of the bylaws of the Company as set forth in the Power of Attorney is now in force.

In testimony whereof, I have hereunto set my hand and seal of Western Surety Company this 5th day of December, 2012.

WESTERN SURETY COMPANY

Paul T. Bruflat
Paul T. Bruflat, Vice President

ACKNOWLEDGMENT OF SURETY

STATE OF Michigan }
COUNTY OF Oakland }

ss (Attorney-in-Fact)

Bond No. 61535407

On this 5th day of December, 2012, before me, a notary public in and for said County, personally appeared Jeanne D Schatz to me personally known and being by me duly sworn, did say, that he is the Attorney-in-Fact of WESTERN SURETY COMPANY, a corporation of Sioux Falls, South Dakota, created, organized and existing under and by virtue of the laws of the State of South Dakota, that the said instrument was executed on behalf of the said corporation by authority of its Board of Directors and that the said Jeanne D Schatz acknowledges said instrument to be the free act and deed of said corporation and that he has authority to sign said instrument without affixing the corporate seal of said corporation.

IN WITNESS WHEREOF, I have hereunto subscribed my name and affixed my official seal at 725 S Adams Rd STE 2 - 105 Billmeyer, MI 48009, 12-05-2012 the day and year last above written.

My commission expires

Mytia Viola Kencaid

Notary Public

Form 108-4-2000 Mytia Viola Kencaid Notary Public of Michigan Wayne County Expires 11/27/2014 Acting in the County of Oakland

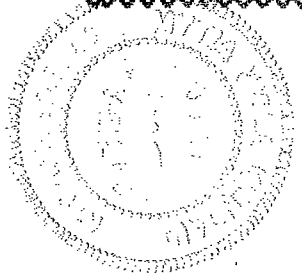

GM100-03

BLUE STAR

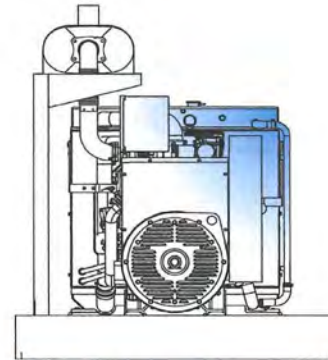
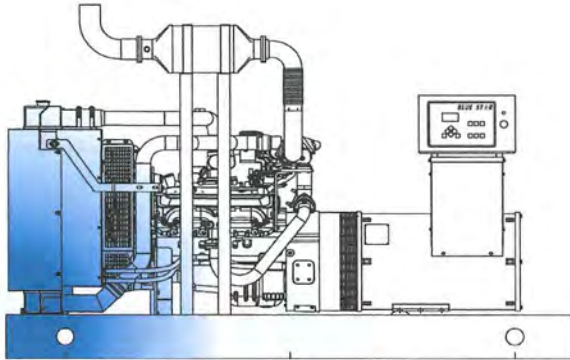

UNIT DIMENSIONS (OPU Less Silencer)

Unit Type	Dimensions (L x W x H)
OPU	96 x 54 x 65 in
LEVEL 1	96 x 54 x 76 in
LEVEL 2	96 x 54 x 104 in
LEVEL 3	136 x 54 x 96 in

UNIT WEIGHT

Unit Type	Weight (Less Tank): lbs (kg)
OPU	2847 (1291)
LEVEL 1	3364 (1526)
LEVEL 2	3856 (1749)
LEVEL 3	4146 (1881)

Dimensions and weights based on standard 480V open power unit. All dimensions and weights may vary with other voltages. Consult factory for installation drawings and accurate weights for your particular unit.

SOUND DATA

Unit Type	Standby		Prime	
	No Load	Full Load	No Load	Full Load
OPU w/ Std Critical Silencer	85 dBA	89 dBA	N/A	N/A
LEVEL 1	82 dBA	87 dBA	N/A	N/A
LEVEL 2 (w/o foam)	81 dBA	85 dBA	N/A	N/A
LEVEL 3	79 dBA	82 dBA	N/A	N/A

INSTALLATION DATA

	Standby		Prime	
Exhaust System				
Gas Temp. (Stack): °F (°C)	1,427 (775)		N/A	
Gas Volume at Stack Temp: CFM (m³/min)	846 (24.0)		N/A	
Maximum Allowable Exhaust Restriction: in. H ₂ O (kPa)	40.8 (10.2)		N/A	
Cooling System				
Ambient Capacity of Radiator: °F (°C)	122 (50)		N/A	
Maximum Allowable Static Pressure on Rad. Exhaust: in. H ₂ O (kPa)	0.5 (0.12)		N/A	
Water Pump Flow Rate: Gpm (lit/min)	39 (147.6)		N/A	
Heat Rejection to Coolant: BTUM (kW)	6,300 (110.3)		N/A	
Heat Rejection to CAC: BTUM (kW)	711 (12.4)		N/A	
Heat Radiated to Ambient: BTUM (kW)	925 (16.2)		N/A	
Air Requirements				
Aspirating: CFM (m³/min)	263 (7.0)		N/A	
Air Flow Required for Rad. Cooled Unit: CFM (m³/min)	16,500 (467)		N/A	
Air Flow Required for Heat Exchanger/Rem. Rad. CFM (m³/min)	Consult Factory For Remote Cooled Applications		N/A	
Fuel Consumption				
	NG	LP	NG	LP
At 100% of Power Rating: ft³/hr (m³/hr)	1,150 (40.4)	420 (11.9)	N/A	N/A
At 75% of Power Rating: ft³/hr (m³/hr)	950 (26.9)	340 (9.6)	N/A	N/A
At 50% of Power Rating: ft³/hr (m³/hr)	870 (24.6)	288 (8.2)	N/A	N/A
Fuel Inlet Size: NPT	1.25"	1.25"	N/A	N/A
Fluids Capacity				
Total Oil System: gal (lit)	1.5 (5.7)		N/A	
Engine Jacket Water Capacity: gal (lit)	2.3 (8.7)		N/A	
System Coolant Capacity: gal (lit)	9.0 (34.0)		N/A	

Specifications subject to change at any time without notice.
FORM #: GM100-03 11-15-11

Deration Factors
Temperature: Derate 1% Per 10°F Over 77°F
Altitude: Derate 3% Per 1000ft Over 328ft

BLUE STAR

Power Systems Inc.

52146 Ember Road
P.O. Box 360
Lake Crystal, MN 56055

Office: 507-726-2508
Fax: 507-726-2670
www.bluestarps.com

Distributed by: _____

Standby Power Rating
100kVA 80kW 60 Hz

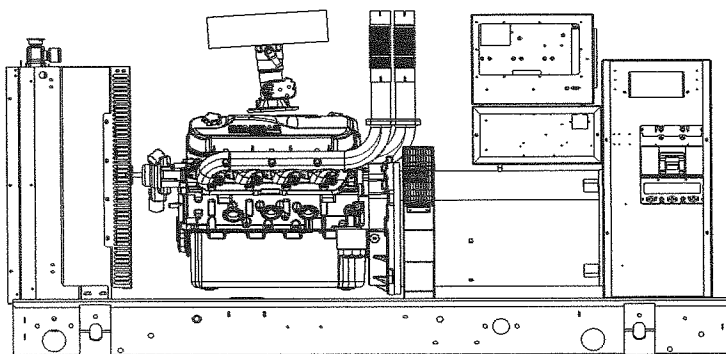

Generator image used for illustration purposes only

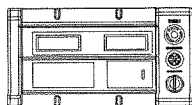
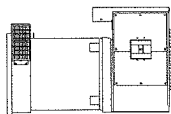
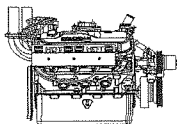
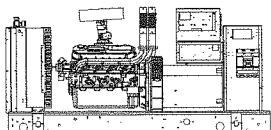

features

benefits

Generator Set

- PROTOTYPE & TORSIONALLY TESTED
- UL2200 TESTED
- RHINOCOAT PAINT SYSTEM
- WIDE RANGE OF ENCLOSURES
- ▶ PROVIDES A PROVEN UNIT
- ▶ ENSURES A QUALITY PRODUCT
- ▶ IMPROVES RESISTANCE TO ELEMENTS
- ▶ PROVIDES A SINGLE SOURCE SOLUTION

Engine

- EPA COMPLIANT
- INDUSTRIAL TESTED, GENERAC DESIGNED
- POWER-MATCHED OUTPUT
- INDUSTRIAL GRADE
- ▶ ENVIRONMENTALLY FRIENDLY
- ▶ ENSURES INDUSTRIAL STANDARDS
- ▶ ENGINEERED FOR PERFORMANCE
- ▶ IMPROVES LONGEVITY AND RELIABILITY

Alternator

- TWO-THIRDS PITCH
- LAYER WOUND ROTOR & STATOR
- CLASS H MATERIALS
- DIGITAL 3-PHASE VOLTAGE CONTROL
- ▶ ELIMINATES HARMFUL 3RD HARMONIC
- ▶ IMPROVES COOLING
- ▶ HEAT TOLERANT DESIGN
- ▶ FAST AND ACCURATE RESPONSE

Controls

- ENCAPSULATED BOARD W/ SEALED HARNESS
- 4-20mA VOLTAGE-TO-CURRENT SENSORS
- SURFACE-MOUNT TECHNOLOGY
- ADVANCED DIAGNOSTICS & COMMUNICATIONS
- ▶ EASY, AFFORDABLE REPLACEMENT
- ▶ NOISE RESISTANT 24/7 MONITORING
- ▶ PROVIDES VIBRATION RESISTANCE
- ▶ HARDENED RELIABILITY

primary codes and standards



SG080

operating data (60Hz)

POWER RATINGS (kW)

	Natural Gas		Propane Vapor	
Single-Phase 120/240VAC @1.0pf	80	Amps: 333	80	Amps: 333
Three-Phase 120/208VAC @0.8pf	80	Amps: 278	80	Amps: 278
Three-Phase 120/240VAC @0.8pf	80	Amps: 241	80	Amps: 241
Three-Phase 277/480VAC @0.8pf	80	Amps: 120	80	Amps: 120
Three-Phase 346/600VAC @0.8pf	80	Amps: 96	80	Amps: 96

STARTING CAPABILITIES (sKVA)

		sKVA vs. Voltage Dip											
		480VAC						208/240VAC					
Alternator	kW	10%	15%	20%	25%	30%	35%	10%	15%	20%	25%	30%	35%
Standard	80	59	88	117	147	176	205	44	66	88	110	132	154
Upsize 1	100	79	118	157	197	236	275	59	89	118	148	177	206
Upsize 2	130	116	174	232	290	348	406	87	131	174	218	261	305

FUEL

Fuel Consumption Rates*

Natural Gas			Propane Vapor			
Percent Load	ft ³ /hr	m ³ /hr	Percent Load	ft ³ /hr	gal/hr	m ³ /hr
25%	343	9.7	25%	147	4.0	4.1
50%	556	15.8	50%	246	6.8	7.0
75%	781	22.1	75%	343	9.4	9.7
100%	1008	28.5	100%	433	11.9	12.3

* Refer to "Emissions Data Sheet" for maximum fuel flow for EPA and SCAQMD permitting purposes.

COOLING

STANDBY		
Air Flow (inlet air combustion and radiator)	ft ³ /min (m ³ /min)	5797 (164.2)
System Coolant Capacity	Gal (Liters)	6 (22.7)
Heat Rejection to Coolant	BTU/hr	159,996
Max. Operating Air Temp on Radiator	°F (°C)	122 (50)
Max. Ambient Temperature	°F (°C)	104 (40)
Maximum Radiator Backpressure	in H ₂ O	0.50

COMBUSTION AIR REQUIREMENTS

STANDBY	
Flow at Rated Power	cfm 282

ENGINE

STANDBY		
Rated Engine Speed	rpm	1800
Horsepower at Rated kW**	hp	127
Piston Speed	ft/min	1275
BMEP	psi	103

EXHAUST

STANDBY		
Exhaust Flow (Rated Output)	cfm (m ³ /min)	866 (24.5)
Maximum Recommended Back Pressure	inHg	1.5
Exhaust Temp (Rated Output)	°F (°C)	1200 (649)
Exhaust Outlet Size (Open Set)	in	2 1/2 x 2

** Refer to "Emissions Data Sheet" for maximum bHP for EPA and SCAQMD permitting purposes.

Deration – Operational characteristics consider maximum ambient conditions. Derate factors may apply under atypical site conditions. Please consult a Generac Power Systems Industrial Dealer for additional details. All performance ratings in accordance with ISO3046, BS5514, ISO8528 and DIN6271 standards.

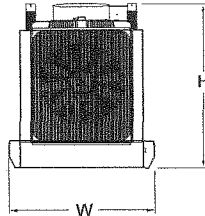
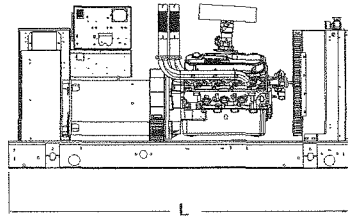

OPEN SET (Includes Exhaust Flex)

L	W	H
93	40	48

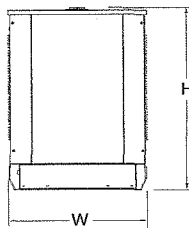
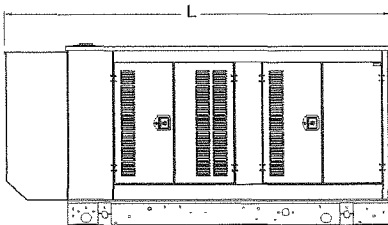

STANDARD ENCLOSURE

L	W	H
112	40	56

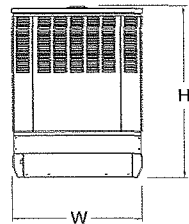
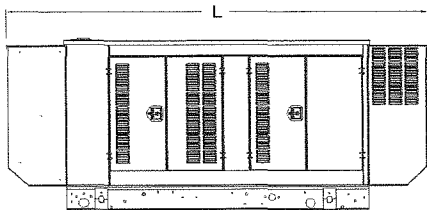

LEVEL 1 ACOUSTIC ENCLOSURE

L	W	H
129	40	56

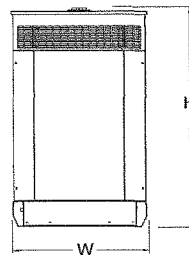
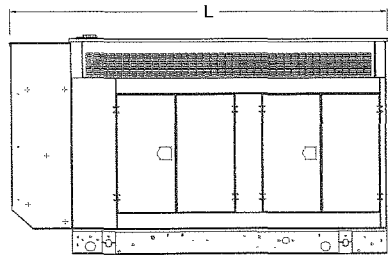

LEVEL 2 ACOUSTIC ENCLOSURE

L	W	H
112	40	69

*All measurements are approximate and for estimation purposes only.

YOUR FACTORY RECOGNIZED GENERAC INDUSTRIAL DEALER

Specification characteristics may change without notice. Dimensions are for preliminary purposes only. Please consult a Generac Power Systems Industrial Dealer for detailed installation drawings.

Generac Power Systems, Inc. • S45 W29290 HWY. 59, Waukesha, WI 53189 • generac.com

©2012 Generac Power Systems, Inc. All rights reserved. All specifications are subject to change without notice. Bulletin 0196180SBY-A / Printed in U.S.A. 08/02/12

INVITATION TO BID



**NOTICE - CITY OF NOVI
INVITATION TO BID**

LIFT STATION GENERATOR

The City of Novi will receive sealed bids for **LIFT STATION GENERATOR** according to the specifications of the City of Novi.

A mandatory pre-bid meeting will be held Tuesday, November 13, 2012 promptly at 2:00 P.M. at the Lift Station located at 25694 Wixom Road, Novi, MI 48374 (between Ten Mile and Eleven Mile Roads).

Sealed bids will be received until **11:00 A.M.** prevailing Eastern Time, **Wednesday, December 5, 2012** at which time bids will be opened and read. Bids shall be addressed as follows and delivered to:

**CITY OF NOVI
CITY CLERK'S OFFICE**
45175 W. Ten Mile Rd.
Novi, MI 48375-3024

All bids must be signed by a legally authorized agent of the bidding firm. **OUTSIDE OF MAILING ENVELOPES/PACKAGES MUST BE PLAINLY MARKED "LIFT STATION GENERATOR BID" AND MUST BEAR THE NAME OF THE BIDDER.**

The City reserves the right to accept any or all alternative bids and award a contract to other than the lowest bidder, to waive any irregularities or informalities or both; to reject any or all bids; to subdivide the award, and in general to make the award of the contract in any manner deemed by the City, in its sole discretion, to be in the best interest of the City of Novi.

Sue Morianti
Purchasing Manager

Notice Dated: November 7, 2012

NOTICE TO BIDDERS:

The City of Novi officially distributes bid documents through the Michigan Intergovernmental Trade Network (MITN). **Copies of bid documents obtained from any other source are not considered official copies.** The City of Novi cannot guarantee the accuracy of any information not obtained from the MITN website and is not responsible for any errors contained by any information received from alternate sources. Only those vendors who obtain bid documents from the MITN system are guaranteed access to receive addendum information, if such information is issued. If you obtained this document from a source other than the source indicated, it is recommended that you register on the MITN site, www.mitn.info and obtain an official copy.



CITY OF NOVI
LIFT STATION GENERATOR
INSTRUCTIONS TO BIDDERS

This bid is issued by the Purchasing Office of the City of Novi.

IMPORTANT DATES

Bid Issue Date	November 7, 2012
Mandatory Pre-bid Meeting	Tuesday, November 13, 2012 promptly at 2:00 P.M. At: 25694 Wixom Road, Novi, MI 48374
Last Date for Questions	Wednesday, November 28, 2012 by 12:00 P.M. Please submit all questions via email to: Sue Morianti, Purchasing Manager smorianti@cityofnovi.org
Response Due Date	Wednesday, December 5, 2012 by 11:00 A.M.
Anticipated Award Date	December 17, 2012

MANDATORY PRE-BID MEETING

The mandatory pre-bid meeting begins promptly at the time listed above and will be closed thereafter to latecomers. It is the vendor's responsibility to take traffic, weather, etc. into consideration in order to arrive at the pre-bid meeting on time.

QUESTIONS

Please email all questions to the person listed above. Please put the name of the Bid/RFP in the subject line. If you put anything else in the subject line, your email may be deleted as spam.

TYPE OF CONTRACT

If a contract is executed as a result of the bid, it stipulates a fixed price for products/ services.

BID SUBMITTALS

An **ORIGINAL and Three (3) copies** of each bid must be submitted. No other distribution of the bids will be made by the Contractor. Bids must be signed by an official authorized to bind the Contractor to its provisions.

FAILURE TO SUBMIT PRICING ON THE BID FORM PROVIDED BY THE CITY OF NOVI MAY CAUSE THE BID TO BE CONSIDERED NON-RESPONSIVE AND INELIGIBLE FOR AWARD.

CHANGES TO THE BID/ADDENDUM

Should any prospective Bidder be in doubt as to the true meaning of any portion of the ITB, or should the Bidder find any patent ambiguity, inconsistency, or omission therein, the Bidder shall make a written request (via email) for official interpretation or correction. Such request shall be submitted to the staff member indicated above. The individual making the request shall be held responsible for its prompt delivery.

Such interpretation or correction, as well as any additional Bid provisions that the City may decide to include, will be made as an addendum, which will be posted on the MITN website at www.mitn.info. Any addendum issued by the City shall become part of the ITB and subsequent contract and shall be taken into account by each bidder in preparing its bid. Only written addenda is binding. It is the Bidder's responsibility to be sure they have obtained all addenda. Receipt of all addenda must be acknowledged on bid form.

SUBMISSION OF BID

Bids must be submitted in a sealed envelope, box, or package, and clearly marked with: ITB Title, Deadline, Respondent's name, address, phone, fax, and contact name. Failure to do so may result in a premature opening or failure to open such proposal.

To be considered, sealed bids must arrive at City Clerk's Office on or before the specified time and date. There will be no exceptions to this requirement. The Clerk's Department time stamp will determine the official receipt time. Contractors mailing bids should allow ample time to ensure the timely delivery of their bid. Bids received after the closing date and time will not be accepted or considered. Faxed, emailed, or telephone bids are not acceptable. The City of Novi shall not be held responsible for lost or misdirected bids. The City reserves the right to postpone a bid opening for its own convenience.

All prices and notations must be typed or printed in ink. No erasures are permitted. Mistakes may be crossed out and corrections must be initialed in ink by the person signing the bid. Bids must be signed by an Authorized Representative of the submitting Company on the enclosed form. Bids must show unit and total prices if requested. In case of mistakes in price extension, unit pricing shall govern.

A bid may be withdrawn by giving written notice to the Purchasing Manager before the stated due date/closing time. After the stated closing time, the bid may not be withdrawn or canceled for a period of One Hundred and Twenty (120) days from closing time.

Failure to include in the bid all information requested may be cause for rejection of the bid.

Bidders are expected to examine all specifications and instructions. Failure to do so will be at the bidder's risk.

Any samples, CDs, DVDs or any other items submitted with your bid will not be returned to the contractor.

No bid will be accepted from, or contract awarded to any person, firm, or corporation that is in arrears or is in default to the City Novi upon any debt or contract, or that is in default as surety or otherwise, or failed to perform faithfully any previous contract with the City.

USE OF THE CITY LOGO IN YOUR BID OR IN ANY OTHER MANNER IS PROHIBITED.

CONSIDERATION OF BIDS

In cases where items are requested by a manufacturer's name, trade name, catalog number or reference, it is understood that the bidder/proposer intends to furnish the item so identified or an item of "equal" quality and value as determined by the City of Novi.

Reference to any of the above is intended to be descriptive, but not restrictive, and only indicates articles that will be satisfactory. Bids of "equal" quality and value will be considered, provided that the bidder states in his/her bid what he/she proposed to furnish, including literature, or other descriptive matter which will clearly indicate the character of the item covered by such bid.

The Purchasing Manager hereby reserves the right to approve as an "equal", any item proposed which contains minor or major variations from specification requirements, but which may comply substantially therewith.

RESPONSIVE BIDS

All pages and the information requested herein shall be furnished completely in compliance with instructions. The manner and format of submission is essential to permit prompt evaluation of all bids on a fair and uniform basis. Unit prices shall be submitted if space is provided on bid form. In cases of mistakes in extension, the unit price shall govern. Accordingly, the City reserves the right to declare as non-responsive, and reject an incomplete bid if material information requested is not furnished, or where indirect or incomplete answers or information is not provided. Any exceptions to the specifications must be noted on the bid form.

EXCEPTIONS

The City will not accept changes or exceptions to the bid documents/specifications unless Contractor indicates the change or exception in the "Exceptions" section of the bid form. If Contractor neglects to make the notation on the bid form but writes it somewhere else within the bid documents and is awarded the contract, the change or exception will not be included as part of the contract. The original terms, conditions and specifications of the bid documents will be applicable during the term of the contract.

CONTRACT AWARD

The contract will be awarded to that responsible, responsive bidder whose bid, conforming to this solicitation, will be most advantageous to the City of Novi. Qualifications, experience, references, comparable projects, price, previous experience with vendor/contractor, delivery, and other factors will be considered in the evaluation process and award of contract. The City reserves the right to accept any or all alternative bids and award the contract to other than the lowest bidder, to waive any irregularities or informalities or both; to reject any or all bids; and in general to make

the award of the contract in any manner deemed by the City, in its sole discretion, to be in the best interest of the City of Novi.

After contract award, a summary of total price information for all submissions will be posted on the MITN website at www.mitn.info.

The City may, from time to time, find it necessary to continue this contract on a month-to-month basis only, not to exceed a six (6) month period. Such month-to-month extended periods shall be by mutual agreement of both parties, with all provisions of the original contract or any extension thereof remaining in full force and effect.

BID BOND

A Bid must be accompanied by Bid security made payable to OWNER (City of Novi) in an amount of 5% of Bidder's maximum Bid price. The required security must be in the form of a certified or bank cashier's check made payable to the City of Novi or a Bid bond by a surety licensed to conduct business in the State of Michigan and named in the current list of "Surety Companies Acceptable on Federal Bonds" as published in the Federal Register by the Audit Staff Bureau of Accounts, U.S. Treasury Department. Attorneys-in-fact who execute the Bid Security or Bid Bond on behalf of the Surety shall affix to the bond a certified copy of the power of attorney. The Bid security of the successful Bidder will be retained until the Agreement has been executed and the successful bidder has furnished the required Contract security, whereupon Bid Security will be returned. If Bidder fails to execute and deliver the Agreement and furnish the required Contract security within ten days of receipt of the Notice of Award, Owner may annul the Notice of Award and the Bid security of that Bidder will be forfeited. The Bid Security of any bidder whom owner believes to have a reasonable chance of receiving the Award may be retained by the OWNER until the earlier of the seven (7) days after the effective date of the Agreement or 90 days after the bid opening. Bid Security of other Bidders will be returned within seven (7) days of the Bid Award.

GENERAL CONDITIONS

INSURANCE

A certificate of insurance naming the City of Novi as an additional insured must be provided by the successful bidder prior to commencement of work. A current certificate of insurance meeting the requirements in Attachment A/Schedule B of the attached Sample Agreement is to be provided to the City and remain in force during the entire contract period.

PERMITS

Where required by code, permits and all required inspections must be obtained by the Contractor. Fees for permits and inspections obtained from the City of Novi will be waived by the City for work on City buildings. Upon completion, all work will be subject to the State Laws and City Ordinance Codes.

TAX EXEMPTION

It is understood that the City of Novi is a governmental unit, and as such, is exempt from the payment of all Michigan State Sales and Federal Excise taxes. Do not include such taxes in the bid prices. The City will furnish the successful bidder with tax exemption certificates when requested. The City's tax-exempt number is 38-6032551.

The following exception shall apply to installation projects: When sales tax is charged to the successful bidder for materials to be installed during the project, that cost shall be included in the "Complete for the sum of" bid price and not charged as a separate line item. The City is not tax exempt in this case and cannot issue an exemption certificate.

FREIGHT CHARGES/SHIPPING/HANDLING

All bid pricing is to be quoted as F.O. B. destination.

DOWN-PAYMENTS OR PRE-PAYMENTS

Any bid proposal submitted which requires a down-payment or prepayment prior to delivery and full acceptance of the item(s) as being in conformance with specifications will not be considered for award.

INVOICING

Invoice must be mailed to: City of Novi, Attn: Finance Department, 45175 W. Ten Mile Road, Novi, MI 48375

CONTRACT TERMINATION

The City may terminate and/or cancel this contract (or any part thereof) at any time during the term, any renewal, or any extension of this contract, upon thirty days (30) days written notice to the Contractor, for any reason, including convenience without incurring obligation or penalty of any kind. The effective date for termination or cancellation shall be clearly stated in the written notice.

TRANSFER OF CONTRACT/SUBCONTRACTING

The successful bidder will be prohibited from assigning, transferring, converting or otherwise disposing of the contract agreement to any other person, company or corporation without the expressed written consent of the City of Novi. Such approval shall not constitute a basis for privity between the City and any subcontractor. Any

subcontractor, so approved, shall be bound by the terms and conditions of the contract. The contractor shall be fully liable for all acts and omissions of its subcontractor(s) and shall indemnify the City of Novi for such acts or omissions.

NON-DISCRIMINATION

In the hiring of employees for the performance of work described in this ITB and subsequent contract, neither the contractor, subcontractor, nor any person acting in their behalf shall by reason of religion, race, color, national origin, age, sex, height, weight, handicap, ancestry, place of birth, sexual preference or marital status discriminate against any person qualified to perform the work required in the execution of the contract.

ACCEPTANCE OF BID CONTENT

Should a contract ensue, the contents of the bid of the successful Bidder may become contractual obligations. Failure of a contractor to accept these obligations may result in cancellation of the award.

DISCLOSURE

All documents, specifications, and correspondence submitted to the City of Novi become the property of the City of Novi and are subject to disclosure under the provisions of Public Act No. 442 of 1976 known as the "Freedom of Information Act". This Act also provides for the complete disclosure of contracts and attachments hereto. This means that any informational material submitted as part of this ITB is available without redaction to any individual or organization upon request.

ECONOMY OF PREPARATION

Bids should be prepared simply and economically, providing a straightforward and concise description of the bidder's ability to meet the requirements of the bid. Emphasis should be on completeness and clarity of content. Included in the response must be a point by point response to the Requirements and other sections of the bid.

The City of Novi is not liable for any costs incurred by bidders prior to issuance of a contract.

INDEPENDENT PRICE DETERMINATION

By submission of a proposal, the offerer certifies, and in case of a joint proposal, each party hereto certifies as to its own organization, that in connection with the proposal:

(a) The prices in the proposal have been arrived at independently without consultation, communication, or agreement, for the purpose of restricting competition, as to any matter relating to such prices with any other offerer or with any other Competitor; and

(b) No attempt has been made or will be made by the offerer to induce any other person or firm to submit or not submit a proposal for the purpose of restricting competition.

Each person signing the proposal certifies that:

(c) He is the person in the offerer's organization responsible within that organization for the decision as to prices being offered in the proposal and that he has not participated and will not participate in any action contrary to (a) and (b) above; or

(d) He is not the person in the offerer's organization responsible within that organization for the decision as to prices being offered in the proposal but that he has been authorized in writing to act as agent for the persons responsible for such decisions in verifying that such persons have not participated, and will not participate, in any action contrary to (a) and (b) above, and that as their agent, does hereby so certify; and that he has not participated, and will not participate in any action contrary to (a) and (b) above.

A proposal will not be considered for award if the sense of the statements required in the proposal has been altered so as to delete or modify the above.



CITY OF NOVI
LIFT STATION GENERATOR
SPECIFICATIONS

Summary

During a recent load bank test of the standby generator located at Island Lake Lift Station #1, the engine component of the generator failed resulting in damage beyond repair. The generator will be replaced as a whole unit as opposed to replacing the damaged engine only. The site has an existing automatic transfer switch (ATS) that may be utilized with the replacement generator.

Location

25694 Wixom Road, Novi, MI 48374 (between Ten Mile and Eleven Mile Roads)

Specifications for Standby 80-90 kW Generator for Sanitary Pumping Station

60Hz-80-90kW

U.S. EPA, stationary emergency application

Natural gas, 60Hz, 80-90 kW standby rating

Duty rated- standby power

Listing UL 2200

Fuel system: natural gas

Enclosure-steel, sound attenuated with quiet exhaust

Voltage – 277/480, 3 phase

Regulator 3 phase sensor

Engine governor-electric, isochronous only

Circuit breaker- single breaker

Circuit breaker-150A, 3 phase, 600/525V, TM, UL/IEC

Skid base – housing ready

Engine starter – 12 VDC motor

Battery charging alternator – normal output

Engine cooling – high ambient air temperature

Shutdown- low coolant level

Coolant heater- 120 Volt AC, single phase

Minimum 1-year warranty

Literature- English

Rack- battery

Fuel strainer- gaseous- 2" NPT inlet/outlet

2 hour on-site full load test with load bank

12 VDC engine starting battery- 750 cold cranking amps

Standard emergency generator start up during normal business hours

Installation

Vendor must provide a new ATS if existing one on site is not compatible.

Vendor must complete plumbing of natural gas pipe, as needed.

Vendor must extend exhaust piping beyond factory mounted components, as needed.

Vendor must install louvers/ducting beyond radiator duct adapter, as needed.

Vendor must provide all equipment and labor for complete installation of components after delivery to the jobsite.

Vendor must make all interconnections between transfer switch and generator set.



**CITY OF NOVI
INSURANCE REQUIREMENTS
ATTACHMENT A**

1. The Contractor shall maintain at its expense during the term of this Contract, the following insurance:
 - a. **Worker's Compensation** insurance with the Michigan statutory limits and Employer's Liability insurance with minimum limits of **\$100,000** (One Hundred Thousand Dollars) each accident.
 - b. **Commercial General Liability Insurance** – The Contractor shall procure and maintain during the life of this contract, Commercial General Liability Insurance, Personal Injury, Bodily Injury and Property Damage on an "Occurrence Basis" with limits of liability not less than **\$1,000,000** (One Million Dollars) per occurrence combined single limit.
 - c. **Automobile Liability** insurance covering all owned, hired and non-owned vehicles with Personal Protection insurance to comply with the provisions of the Michigan No Fault Insurance Law including Residual Liability insurance with minimum bodily injury limits of **\$1,000,000** (One Million Dollars) each person and **\$1,000,000** (One Million Dollars) each occurrence and minimum property damage limits of **\$1,000,000** (One Million Dollars) each occurrence.
2. All policies shall name the Contractor as the insured and shall be accompanied by a commitment from the insurer that such policies shall not be canceled or reduced without at least thirty (30) days prior notice date to the City; alternately, contractor may agree to provide notice of such cancellation or reduction.
3. The City of Novi shall be named as Additional Insured for General Liability and Auto Liability. Certificates of Insurance evidencing such coverage shall be submitted to City of Novi, Purchasing Department, 45175 West Ten Mile Road, Novi, Michigan 48375-3024 prior to commencement of performance under this Contract and at least fifteen (15) days prior to the expiration dates of expiring policies. A current certificate of insurance must be on file with the City for the duration of the contract. Said coverage shall be primary coverage rather than any policies and insurance self-insurance retention owned or maintained by the City. Policies shall be issued by insurers who endorse the policies to reflect that, in the event of payment of any loss or damages, subrogation rights under those contract documents will be waived by the insurer with respect to claims against the City
4. The Contractor shall be responsible for payment of all deductibles contained in any insurance required hereunder.
5. If, during the term of this Contract, changed conditions or other pertinent factors should in the reasonable judgment of the City render inadequate insurance

limits, the Contractor will furnish on demand such additional coverage as may reasonably be required under the circumstances. All such insurance shall be effected at the Contractor's expense, under valid and enforceable policies, issued by the insurers of recognized responsibility which are well-rated by national rating organizations and are acceptable to the City.

6. If any work is sublet in connection with this Contract, the Contractor shall require each subcontractor to effect and maintain at least the same types and limits of insurance as fixed for the Contractor.
7. The provisions requiring the Contractor to carry said insurance shall not be construed in any manner as waiving or restricting the liability of the Contractor under this contract.
8. The City has the authority to vary from the specified limits as deemed necessary.

ADDITIONAL REQUIREMENTS
Indemnity/Hold Harmless

1. The Contractor agrees to save harmless and defend the City against and from any or all liability, loss or damages (including without limitations, fees and expenses of attorneys, expert witnesses and other consultants) which the City may suffer as a result of claims, demands, costs, or judgments against it arising from, out of or in consequence of the performance of this Agreement, excepting only such liability, loss or damage as shall have been occasioned by the sole negligence of the City of Novi, its officers, agents or employees.
2. The Contractor agrees that it is its responsibility and not the responsibility of the City to safeguard the property and materials used in performing this Contract. Further the Contractor agrees to hold the City harmless for any loss of such property and materials used pursuant to the Contractor's performance under this Contract.
3. The Contractor shall not discriminate against any employee, or applicant for employment because of race, color, sex, age, or handicap, religion, ancestry, marital status, national origin, place of birth, or sexual preference. The Contractor further covenants that it will comply with the Civil Rights Act of 1973, as amended; and the Michigan Civil Rights Act of 1976 (78. Stat. 252 and 1976 PA 453) and will require a similar covenant on the part of any consultant or subcontractor employed in the performance of this contract.



**CITY OF NOVI
BID FORM**

LIFT STATION GENERATOR

We the undersigned, as bidder, propose to furnish to the City of Novi, according to the terms, conditions, and instructions attached hereto and made a part thereof:

A. Lift Station Generator \$ _____ Lump Sum

Make/Model _____

B. Transfer Switch (choose one)

- We are able to use the existing transfer switch.
- We are unable to use the existing transfer switch. The additional cost for a new transfer switch is \$ _____.

Delivery date _____

Warranty: _____

REFERENCES: Please provide at least three client (3) references for projects of similar scope done in the last 3 years.

Company _____

Address _____

Phone _____ Contact name _____

Company _____

Address _____

Phone _____ Contact name _____

Company _____

Address _____

Phone _____ Contact name _____

EXCEPTIONS TO SPECIFICATIONS (all exceptions must be indicated here):

COMMENTS: _____

We acknowledge receipt of the following Addenda: _____
(please indicate numbers)

THIS BID SUBMITTED BY:

Company (Legal Registration) _____

Address _____

City _____ State _____ Zip _____

Telephone _____ Fax _____

Representative's Name (please print) _____

Representative's Title _____

Representative's Signature _____

E-mail _____

Date _____

**CITY OF NOVI
LIFT STATION GENERATOR**

Please return this page with your bid form

If your company is awarded the item(s) referenced in the bid proposal, other governmental entities may wish to use this contract and will issue a purchase order or contract for the item(s) awarded in the bid proposal following minimum order/contract requirements set forth in the bid documents. Each entity will provide their own purchase order and delivery location(s) and must be invoiced separately to the address indicated on their purchase order.

1. EXTENSION OF AWARD TO THE MITN (MICHIGAN INTER-GOVERNMENTAL TRADE NETWORK) PURCHASING COOPERATIVE: OPTIONAL

Numerous Counties, Cities, Townships, and Authorities of the State of Michigan are members of the MITN (Michigan Inter-governmental Trade Network) Purchasing Cooperative. Other associate entities are also members of the Cooperative in the Tri-County area. Please visit www.mitn.info website to view the entire list of participating agencies.

() If an award is made to _____, it is agreed that the contract will be extended to other MITN Purchasing Cooperative members and associate entities under the same prices, terms, and conditions.

() Our company is **NOT** interested in extending the contract to those MITN members listed on the website.

2. EXTENSION OF AWARD TO THE CITY OF NORTHVILLE: OPTIONAL

The City of Novi is working with the Novi Community School District, City of Northville, Northville Community School District and the Walled Lake Consolidated Schools to discover opportunities to optimize procurement services.

() If an award is made to _____, it is agreed that the contract will be extended to Novi Community School District, City of Northville, Northville Community School District and the Walled Lake Consolidated Schools under the same prices, terms, and conditions.

() Our company is **NOT** interested in extending the contract to Novi Community School District, City of Northville, Northville Community School District and the Walled Lake Consolidated Schools under the same prices, terms, and conditions.

Contractor Signature: _____

Company Name: _____

Date: _____

SAMPLE AGREEMENT

CONTRACT FOR _____

This Agreement shall be considered as made and entered into as of the date of the last signature ("Effective Date"), and is between the City of Novi, a Michigan municipal corporation, whose address is 45175 W. Ten Mile, Novi, Michigan 48375, (hereinafter referred to as "Client"), and _____, whose address is _____, (hereinafter referred to as "Contractor").

THE CLIENT AND CONTRACTOR AGREE AS FOLLOWS:

Article I. Statement and Performance of Work.

For payment by the Client as provided under this Contract, Contractor shall provide the materials and perform the services described on and in Schedule A (the "Work"), which is attached hereto and made a part of this Contract by this reference, in a competent, accurate, efficient, timely, good, professional, thorough, complete and responsible manner, and in compliance with the terms and conditions set forth below.

Article II. Timing of Performance.

Performance of this Contract shall commence on _____, delivery of the materials and performance of the work shall be completed according to the timing set forth as part of Schedule A. The completion date for all services and delivery of all materials as described in Schedule A shall be _____, provided, however, that if delays in construction of the building delay contractor's performance, the completion date shall be extended for a period equal to the period of delay. The timing for performance of any such work may also be extended, if allowed in writing by the Client in its sole discretion.

Article III. Contract Price and Payment.

Subject to the terms and conditions of this Contract, the Client agrees to pay Contractor an amount not to exceed \$_____ for services and materials as specifically set forth in the completed Proposal attached which are part of the attached Schedule A. Such payments are in exchange for and consideration of the timely and satisfactory performance and completion of the work required under and pursuant to this Contract. The Client agrees to pay Contractor amounts due within thirty (30) days of receipt of an itemized billing/invoice from Contractor detailing all materials provided and work performed in connection with the billing and the hours and charges applicable to each such item. Such itemized billings shall be submitted and shall be paid only upon satisfactory completion of the work itemized in the billing.

All costs and expenses incurred by Contractor under this Contract are deemed to be included in the amounts set forth in Schedule A, unless specifically identified in Schedule A as reimbursable expenses and such expenses have been approved by the Client or its designee. Contractor will obtain written approval of the Client prior to proceeding with any work that is not stated on Schedule A; otherwise, the Client will not be billed for such extra/additional work.

SAMPLE AGREEMENT

Payments shall be made upon verification of invoices received by the Client. All payments to Contractor shall be submitted by mail at Contractor's address first listed above, unless Contractor provides written notice of a change in the address to which such payments are to be sent.

Article IV: Termination.

A. 1. For cause: In the event that either party shall breach the terms and conditions of this Contract, the aggrieved party may notify the other party, in writing via certified mail, of such breach and demand that the same be remedied within ten (10) days. If the defaulting party fails to remedy the breach as demanded, the aggrieved party shall then have the right to terminate by giving the defaulting party thirty (30) days written notice. In addition, if at any time a voluntary petition in bankruptcy shall be filed against either party and shall not be dismissed within thirty (30) days, or if either party shall take advantage of any insolvency law, or if a receiver or trustee of any of a party's property shall be appointed and such appointments shall not be vacated within thirty (30) days, the other party shall have the right, in addition to any other rights of whatsoever nature that it may have at law or in equity, to terminate by giving thirty (30) days notice in writing of such termination.

2. For convenience: The Client may terminate the agreement, in whole or in part, without showing cause upon giving thirty (30) days written notice to the Contractor. The Client shall pay all reasonable costs incurred by the Client up to the date of notice of termination. The Contractor will not be reimbursed for any anticipatory profits that have not been earned up to the date of notice of termination.

B. In the event this Contract is terminated before completion, the Client shall not be responsible to make any further payments for work performed after the effective date of such termination, and shall pay Contractor for such materials as have been delivered and for such work as has been completed and is eligible for payment under the terms of this Contract through the date of such termination. In all events, the Client shall only be responsible to make the payments described in the preceding sentence if, at the Client's request, Contractor continues to fully perform its duties and obligations in full compliance with the terms of this Contract through the effective date of the termination.

Article V: Independent Contractor/Vendor Relationship.

A. In the performance of this Contract, the relationship of Contractor to the Client shall be that of an independent contractor and/or vendor and not that of an employee or agent of Client. Contractor is and shall perform under this Contract as an independent contractor and/or vendor, and no liability or responsibility with respect to benefits of any kind, including without limitation, medical benefits, worker's compensation, pension rights, or other rights or liabilities arising out of or related to a contract for hire or employer/employee relationship shall arise or accrue to either party as a result of the performance of this Contract.

SAMPLE AGREEMENT

Contractor, as an independent contractor and/or vendor, is not authorized to enter into or sign any agreements on behalf of the Client or to make any representations to third parties that are binding upon the Client.

- B. Contractor represents that it will dedicate sufficient resources and provide all necessary personnel required to perform the work described in Schedule A in accordance with the terms and conditions of this Contract. Except as may be specifically stated and agreed to in Schedule A, Contractor shall perform all of the work under this Contract and no other person or entity shall be assigned or sub-contracted to perform the work, or any part thereof, unless approved by the Client in advance.

Article VI: Liability and Insurance.

- A. Contractor agrees to indemnify and hold harmless the Client, its elected and appointed officials and employees, from and against any and all claims, demands, suits, losses and settlements, including actual attorney fees incurred and all costs connected therewith, for any damages which may be asserted, claimed or recovered against the Client by reason of (i) personal injury, death and/or property damages which arises out of or is in any way connected or associated with the actions or inactions of Contractor in performing or failing to perform the work; or (ii) civil damages which arise out of any dispute between Contractor and its subcontractors, affiliates, employees or other private third parties in connection with this Contract. Contractor specifically agrees that it is Contractor's responsibility, and not the responsibility of the Client, to safeguard the property and materials used in performing this Contract. Contractor agrees to hold the City harmless from any loss of or damage to such property and materials used in connection with Contractor's performance of this Contract.
- B. Contractor shall provide evidence of adequate insurance coverage in the types and amounts set forth on Schedule B, which is attached hereto and incorporated herein by this reference. Such insurance shall be maintained at the specified level of coverage throughout the term of this Contract, including any extension of such term, and will cover all work, acts and omissions by and on behalf of Contractor in connection with this Contract, with the Client as named additional insureds, but with such coverage being primary and non-contributory as described in the attached Schedule B.

Article VII: Information.

It is expressly acknowledged and agreed that all reports, opinions, compilations, research work, studies, data, materials, artifacts, samples, documents, plans, drawings, specifications, correspondence, ledgers, permits, manuals, applications, contracts, accountings, schedules, maps, logs, invoices, billings, photographs, videotapes and all other materials generated by and/or coming into the possession of Contractor during the term of this Contract, and any extension thereof, that in any way relate to the performance of work by Contractor under this Contract or that are otherwise related or relevant to the work, belong exclusively to the Client and shall be promptly delivered to

SAMPLE AGREEMENT

the Client upon the termination of this Contract or, at any time, upon the Client's request.

Article VIII: **General Provisions.**

- A. Entire Agreement. This instrument, together with the attached Schedules, contains the entire Contract between the Client and Contractor. No verbal agreement, conversation, or representation by or between any officer, agent, or employee of the parties hereto, either before or after the execution of this Contract, shall affect or modify any of the terms or obligations herein contained.
- B. Compliance with Laws. This Contract and all of Contractor's work and practices shall be subject to all applicable state, federal and local laws, ordinances, rules or regulations, including without limitation, those which apply because Client is a public governmental agency or body. Contractor represents that it is in compliance with all such laws and eligible and qualified to enter into this Contract.
- C. Governing Law. This Contract shall be governed by the laws of the State of Michigan.
- D. Assignment. Contractor shall not assign this Contract or any part thereof without the written consent of the Client. This Contract shall be binding on the parties, their successors, assigns and legal representatives.
- E. Dispute Resolution/Arbitration. The parties agree that any disputes regarding a claimed violation of this agreement shall first be submitted in writing to the other party in an attempt to settle the matter before pursuing other legal actions or notices provided for in this agreement. Such written communication shall clearly state the problem or concern, allow sufficient time for a written response from the other party, and culminate in a face-to-face meeting to determine if a remedial action is possible. In no event shall this process take more than thirty (30) days, unless a specific extended period of time is agreed to by both parties in writing as being necessary. The aforementioned initial written communications between the parties also shall indicate whether the party is willing to submit the dispute to binding arbitration, non-binding mediation or other form of alternate dispute resolution, and share equally the costs for same. Upon the parties agreeing to any such method of dispute resolution and a timetable for doing so, pursuit of other legal actions shall be deferred until the process has been completed. In any binding arbitration, the arbitrator shall provide a written statement of the reasons and basis for an award or decision, a judgment of the Oakland County Circuit Court may be entered based on the arbitration award or decision, and each party shall be responsible for their own costs and attorney fees.
- F. Third Parties. It is the intention of the parties hereto that this Agreement is not made for the benefit of any private third party. It is acknowledged that Client may receive a portion of the funding for the payments under this Contract from one or more private sources, and it is understood by Contractor that it is hired by Client to work exclusively for Client (and by extension for the Township should the work be

SAMPLE AGREEMENT

accepted and implemented by the Township) and Contractor agrees that no private party or parties will be allowed to hold sway or influence, in any way, over Contractor's performance of the work.

G. Notices. Written notices under this Contract shall be given to the parties at their addresses contained in this Contract by personal or registered mail delivery to the attention of the following persons:

Client: City Manager Clay J. Pearson and City Clerk Maryanne Cornelius
Contractor:

H. Changes. Any changes in the provisions of this Contract must be in writing and signed by the Client and Contractor.

I. Waivers. No waiver of any term or condition of this Contract shall be binding and effective unless in writing and signed by all parties, with any such waiver being limited to that circumstance only and not applicable to subsequent actions or events.

J. Jurisdiction and Venue of Contract. This Contract shall be considered for all purposes, including the establishment of jurisdiction and venue in any court action between the parties, as having been entered into and consummated in the City of Novi, Oakland County, Michigan.

K. Conflict. In the event of any conflict or inconsistency between the above provisions of this Contract and either or both of the attached Schedules, the provisions in the above text shall govern.

IN WITNESS WHEREOF, the Client and the Contractor have executed this Contract in Oakland County, Michigan, as of the date first listed above.

WITNESS:

CITY OF NOVI

Date: _____

By: Robert J. Gatt
Its: Mayor

Date: _____

By: Maryanne Cornelius
Its: Clerk

CONTRACTOR

Date: _____

By:
Its:

SCHEDULE B

A. Insurance Requirements

The vendor will not commence work, nor will the City of Novi sign a contract, until vendor has obtained and delivered to the City of Novi the certificate of insurance required under this contract. All insurance carriers must be acceptable to the City of Novi and licensed and admitted to do business in the State of Michigan.

A new certificate of insurance will be provided to the City of Novi at the time of policy renewal any time during the entire length of the contract.

1. Coverage: The Vendor shall maintain at its expense during the term of this Contract, the following insurance:
 - a. **Worker's Compensation** insurance with the Michigan statutory limits and Employer's Liability insurance with minimum limits of **\$100,000** (One Hundred Thousand Dollars) each accident.
 - b. **Commercial General Liability Insurance** – The Contractor shall procure and maintain during the life of this contract, Commercial General Liability Insurance, Personal Injury, Bodily Injury and Property Damage on an "Occurrence Basis" with limits of liability not less than **\$1,000,000** (One Million Dollars) per occurrence combined single limit.
 - c. **Automobile Liability** insurance covering all owned, hired and non-owned vehicles with Personal Protection insurance to comply with the provisions of the Michigan No Fault Insurance Law including Residual Liability insurance with minimum bodily injury limits of **\$1,000,000** (One Million Dollars) each person and **\$1,000,000** (One Million Dollars) each occurrence and minimum property damage limits of **\$1,000,000** (One Million Dollars) each occurrence.
2. Deductibles: The Vendor shall be responsible for payment of all deductibles contained in any insurance required hereunder.
3. Insured: All policies shall name the Vendor as the insured.
4. Cancellation Notice: All policies shall include the following language: "Should any of the above policies be cancelled before the expiration date thereof, the issuing insurer will mail 30 days written notice to the certificate holder named on this certificate; alternately, contractor may agree to provide notice of such cancellation or reduction".
5. Additional Insured: All policies include the following language "The City of Novi, their officers, agents, employees and volunteers, all boards, commissions and/or authorities and board members, including employees and volunteers thereof are added as additional insured." Certificates of Insurance evidencing such coverage shall be submitted to Purchasing Manager, City of Novi, 45175 W. Ten

SAMPLE AGREEMENT

Mile Rd., Novi, MI 48375 prior to commencement of performance under this Contract and at least 15 days prior to the expiration dates of expiring policies.

6. If any work is sublet in connection with this Contract, the Vendor shall require each subcontractor to effect and maintain at least the same types and limits of insurance as fixed for the Contractor.
7. The provisions requiring the Vendor to carry said insurance shall not be construed in any manner as waiving or restricting the liability of the Contractor under this contract.
8. The City of Novi has the authority to vary from the specified limits as deemed necessary.
9. If, during the term of this Contract, changed conditions or other pertinent factors should in the reasonable judgment of the City of Novi render inadequate insurance limits, the Vendor will furnish on demand such additional coverage as may reasonably be required under the circumstances. All such insurance shall be effected at the Vendor's expense, under valid and enforceable policies, issued by the insurers of recognized responsibility which are well-rated by national rating organizations and are acceptable to the City.
10. Hold harmless/Indemnity
 - a. The Vendor agrees to save harmless and defend the City of Novi against and from any or all liability, loss or damages (including without limitations, fees and expenses of attorneys, expert witnesses and other consultants) which the City of Novi may suffer as a result of claims, demands, costs, or judgments against it arising from , out of or in consequence of the performance of this agreement, excepting only such liability, loss or damage as shall have been occasioned by the sole negligence of the City of Novi, it's officers, agents, or employees.
 - b. The Vendor agrees that is it its responsibility and not the responsibility of the City of Novi to safeguard the property and materials used in performing this contract. Further, the Vendor agrees to hold the City of Novi harmless for any loss of such property and materials used pursuant to the Vendors performance under this contract.
 - c. The Vendor shall not discriminate against any employee, or applicant for employment who is qualified to perform the work required in the execution of this contract because of religion, race, color, national origin, age, sex, height, weight, handicap, ancestry, place of birth, sexual preference or marital status. The Vendor further covenants that it will comply with the Civil Rights Act of 1973, as amended; and the Michigan Civil Rights Act of 1976 (78. Stat. 252 and 1976 PA 453) and will require a similar covenant on the part of any consultant or subcontractor employed in the performance of this contract.

**CITY OF NOVI
SIGN-IN SHEET FOR MANDATORY PRE-BID MEETING FOR
LIFT STATION GENERATOR**

Pre-bid meeting 11/13/12 2:00 p.m.
Bids due 12/5/12 11:00 a.m.

Company Name	Address	Representative name	Phone Number
PHOENIX Environmental Inc	11042 HITECH DR. WHITMORE LAKE	BRUCE CARY	734-449-1266
GREAT LAKES PWR & LTB.	9646 MARINE CRY HWY CASCO MI	MIKE TOBAUGH	586-716-4000
J. Bonck Electric	3015 AIRPARK DR. FLINT MI	Adam Gots	989-239-4116
CUMMINS BRIDGEWAY	21810 CLESSIE CT. ^{NEW} HUDSON, MI	FRED KLEMM	248-573-1522
Airport Lighting	PO Box 810 LUTHER MI 49656	Jordan Gault	(517) 930-5053
WILLIAMS	4600 STEELER DENVERBORO MI	MIKE PETERS	526-454-6396
Waterline Power Sys. GENERAC	50160 Pontiac Trl, Wixom 48393	John Castro	616-218-4566
Mark McVicar	6001 Siskiwit Dr Berkshire MI 48111	Mark McVicar	734 547 9237
American Generators	6150 DETFIELD ST Waterford	Leah Cavalieri	248 623 4919
GEN Power Products	29905 ANTHONY DR. ^{Wixom} MI 48393	BOB NARRAGAN	P 248-624-7320 F 248-624-6440



CITY OF NOVI
LIFT STATION GENERATOR
ADDENDUM #1

INTENT: This addendum has been issued to modify and/or interpret the original specifications for the bid/RFP named above. Unless otherwise instructed, the information contained within this Addendum shall take precedence over anything contrary in the original specifications, and shall hereinafter be considered as part of the package.

RESPONSE: The Contractor shall verify receipt of this Addendum on the Bid Form.

CONTENTS: Included in this Addendum is one (1) page of written addenda description, plus one page consisting of the pre-bid meeting sign-in sheet.

CLARIFICATIONS:

1. The City will be removing the battery and battery charger prior to the start of the project. The City will be keeping them in stock to be used on other units in the future.
2. Contractor will include the removal and installation of a new concrete pad in the lump sum price.

QUESTIONS:

1. Do you want a sound attenuated enclosure even though the current one is not sound attenuated?
Answer: Yes, we want a sound attenuated enclosure.
2. Where is the current grounding?
Answer: We are not sure.

Sue Morianti
Purchasing Manager

Notice dated: November 27, 2012



CITY OF NOVI
LIFT STATION GENERATOR
ADDENDUM #2

INTENT: This addendum has been issued to modify and/or interpret the original specifications for the bid/RFP named above. Unless otherwise instructed, the information contained within this Addendum shall take precedence over anything contrary in the original specifications, and shall hereinafter be considered as part of the package.

RESPONSE: The Contractor shall verify receipt of this Addendum on the Bid Form.

CONTENTS: Included in this Addendum is one (1) page of written addenda description plus a photo.

QUESTIONS:

1. Can you verify that the existing transfer switch currently is a "2 wire" start system?

Answer: Yes, it is a 2 wire start. See attached photo.

2. The addendum states that the City will remove the battery charger and battery and will keep them in stock to be used on other units in the future. Are you going to reuse them on this new generator purchase? If not, please note that you have not requested a battery charger in the advertisement for bid.

Answer: No, we do not intend to use the current battery or battery charger on the new generator. Contractor should include a new battery and a battery charger (installed) in the lump sum price.

Sue Morianti
Purchasing Manager

Notice dated: November 28, 2012

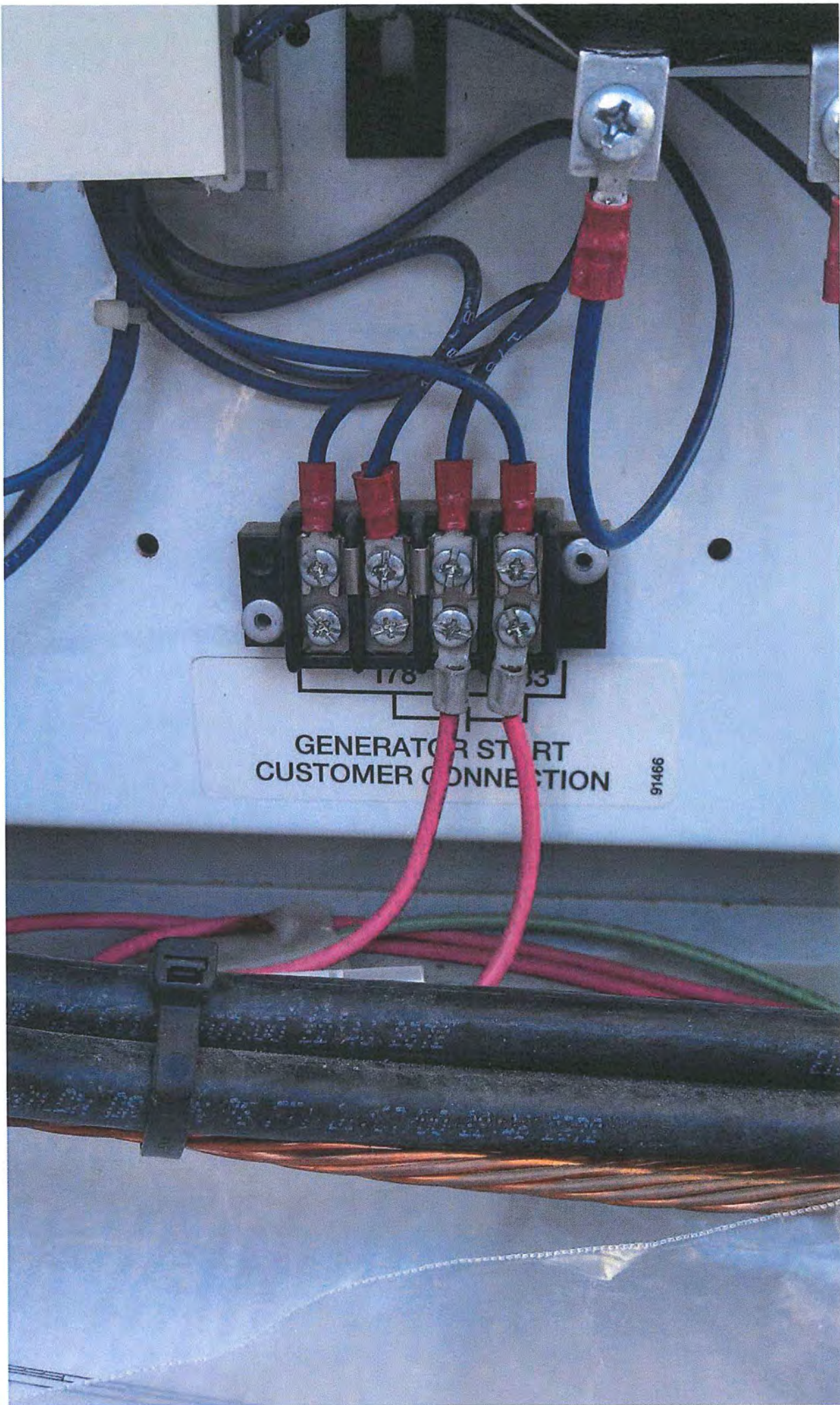

GENERATOR START
CUSTOMER CONNECTION

91466