

RECEIVED
OCT 09 2007
CITY OF NOVI
COMMUNITY DEVELOPMENT

To Whom It May Concern:

I am writing with regard to Mixx Lounge and its appeal to the Novi ZBA to allow the following: Move the current Mixx Lounge sign to the rear of the building and construct a new sign to be put on the front of the building.

This appeal is based on the following grounds:

- New customers are having a difficult time locating the Lounge. By adding the rear elevation sign, we feel potential customers will be able to view the sign from Grand River Avenue. Also, the majority (90% plus) of available parking is located in the rear of the Main Street development and this sign would allow customers to locate Mixx Lounge.
- New customers are not able to see the current sign on the front of the building until they are directly in front of the location. A projecting sign would allow potential customers to see the sign from either direction on Main Street and not have to be directly in front of Mixx to know where we are.
- With anticipation of the Triangle development, which we fully support, construction will limit traffic flow on Main Street and more customers will be using the Grand River side to approach Main Street and park.

We appreciate the Zoning Board of Appeals consideration of this application.

Sincerely,
Randy Gregory
Mixx Lounge
248.640.6721

RECEIVED

NOV 09 2007

CITY OF NOVI
COMMUNITY DEVELOPMENT

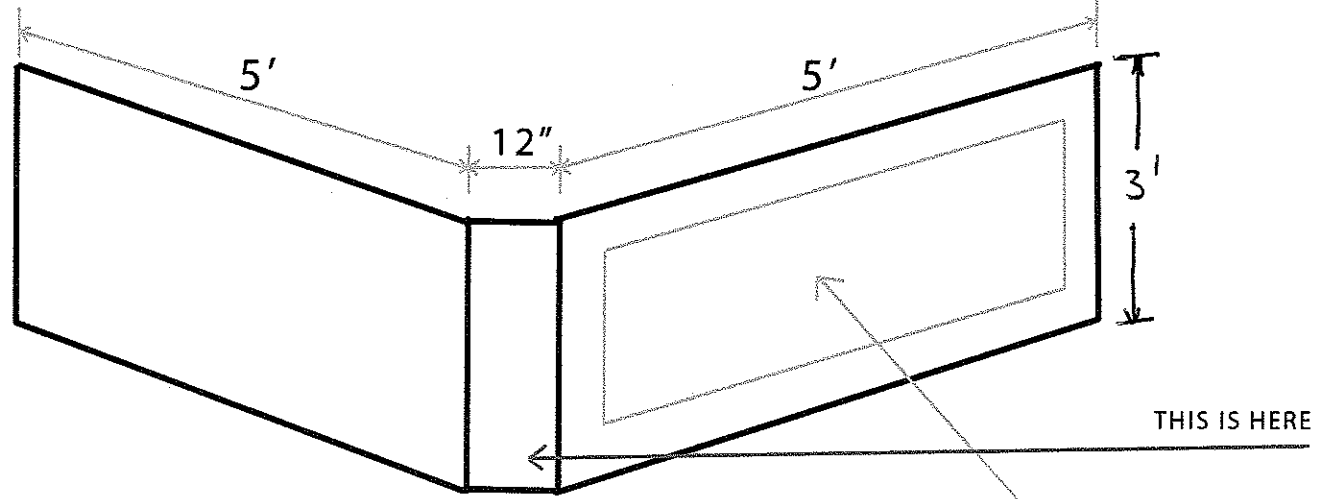

COCKTAILS

THIS IS HERE

TOP VIEW

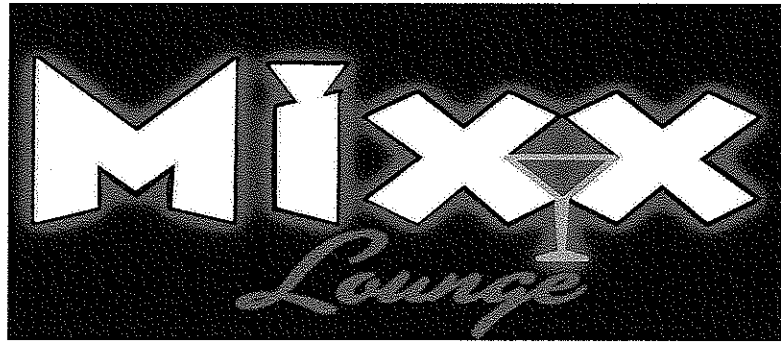

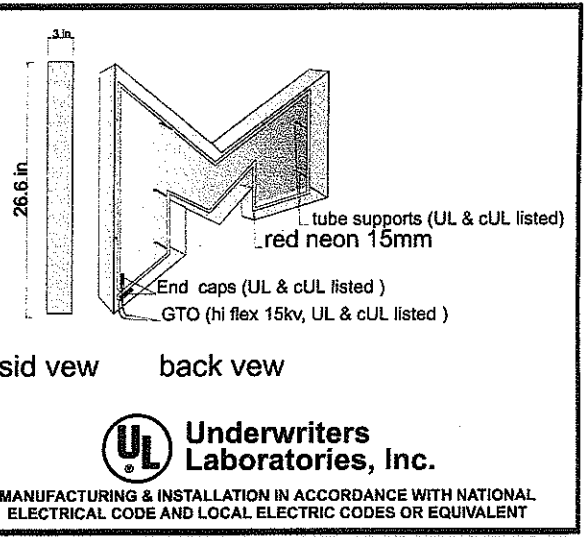

UL Underwriters Laboratories, Inc.
 MANUFACTURING & INSTALLATION IN ACCORDANCE WITH NATIONAL ELECTRICAL CODE AND LOCAL ELECTRIC CODES OR EQUIVALENT

Sign Description:

Text Information:
 (A) U/C: _____ L/C: _____ Font: _____
 (B) U/C: _____ L/C: _____ Font: _____
 (C) U/C: _____ L/C: _____ Font: _____

File Name:	mixx luonge xx	Date:	mar 06
Sales Person:	scott david	Revised:	00/00/00
Artwork By:	xx	Scale:	x=x
Customer:			
Address:			
	XX		
Phone#:		Sq. Footage:	30.96 SFT

ACCEPTANCE OF ARTWORK - The drawing above is an artistic interpretation ONLY; elements may vary based on field measurements. This color proof is intended for verification of spelling, layout, color and composition. (PLEASE HELP AVOID UNNECESSARY COSTS BY CHECKING THIS PROOF VERY CAREFULLY) Signature constitutes authorization to proceed with specifications and conditions of this document as specified. All artwork and designs are property of Art One Signs and may not be used without the expressed written permission of Art One Signs.

Approval _____ Date _____

Phone: 248-591-ART1 (2781)
 8915 Northend, Royal Oak Twp., MI 48220
 Copy Right by Art One Signs



MainStreet Partnership, LLC. 43155 Main Street, Suite 500, Novi, Mi 48375
P. 248-305-9154 F. 248-374-2089 email: atriumofnovi@gmail.com

November 9, 2007

To Whom it May Concern

We have reviewed the art work for a proposed signs for MIXX Lounge.

MainStreet Partnership does not have any objection to such signs as proposed by Novi Cocktail Lounge dba: MIXX Lounge.

In case of any questions we can be contacted at 248-305-9154.

Sincerely,

A. Hafeez Shaikh
Partner

3. Dimensional Letter Sign - Dimensional Letter Signs shall be defined as individual letters with opaque face and sides, pin mounted to the building facade. Sides of letters shall not be greater than 4". Text shall be 3" minimum height, and 36" maximum height. All Dimensional Letter Signs shall be illuminated using externally mounted "gooseneck" style fixtures spaced as required to provide even illumination over full area of the sign. Illumination of the Wall Sign may be eliminated if the Projecting Sign on the same establishment is illuminated. Letters shall be fabricated of metal or acrylic (note that wood is prohibited) designed to resist deleterious effects of weather exposure, and shall be mounted to the building facade using stainless steel anchors to prevent staining.

Examples of Allowable Wall Signs are provided in Figures "A" and "D", attached.

Prohibited Wall Signs: Translucent Internally Illuminated Signs such as Channel Letter Signs, Box Signs, and exposed luminaires of any type including neon are prohibited. Examples of Prohibited Wall Signs are provided in Figure "E", attached.

Allowable Projecting Signs:

1. Pedestrian Level Projecting Sign - Pedestrian Level Projecting Signs shall be defined as signs mounted perpendicular (90 degrees) to the building facade, located in its entirety between twelve (12) feet and eight (8) feet above the pedestrian walkway. Pedestrian Level Projecting Signs shall be securely mounted using ornamental brackets attached to either the building facade or from permanent overhanging canopies (chain or hinge mounting is prohibited). Projecting signs shall be "double sided" having text on two faces. The overall shape and design of the sign and mounting brackets shall be consistent with the neo traditional style associated with the Main Street project. All signs and brackets shall exhibit ornamental features consistent with the examples shown in Figure "C", attached. All text shall be raised from the background by not less than 3/4" nor more than 2", and be of a contrasting color from the background. The background shall be framed on both faces by a decorative molded edge raised above the background not less than the dimension that the letters are raised above the background. Logos, graphics, and features other than text are encouraged and may be painted directly on the background. All signs shall be illuminated using externally mounted "gooseneck" style fixtures mounted on the sign bracket or the building facade. Illumination of the Pedestrian Level Projecting Signs may be eliminated if the Wall Sign on the same establishment is illuminated. Signs shall be fabricated of wood, metal, or acrylic letters mounted to a solid background designed to resist deleterious effects of weather exposure.

TC-1 SIGN DESIGN REVIEW MANUAL - FIGURE "C" PEDESTRAIN LEVEL PROJECTION SIGNS

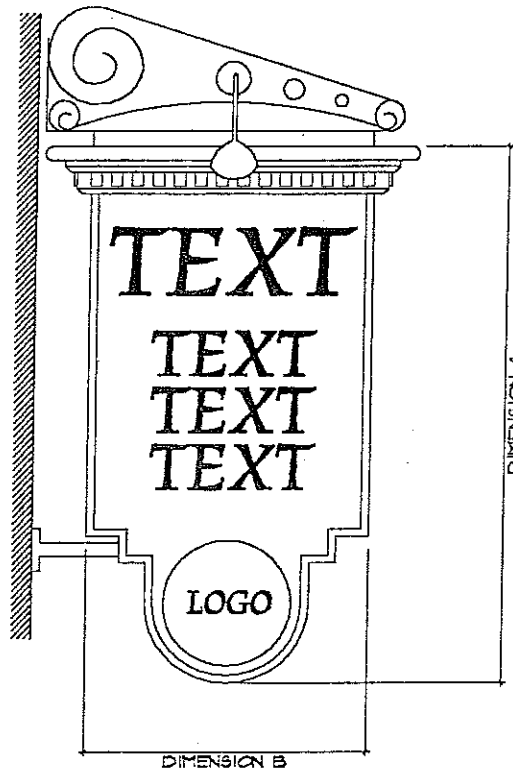

AREA = A X B

