

ZONING BOARD OF APPEALS
CITY OF NOVI
Community Development Department
(248) 347-0415

Case No. 12-020 28125 Cabot Drive

Location: 28125 Cabot Drive

Zoning District: OST, Office Service Technology District

The applicant is requesting an exception from Section 28-5(3)f. of the Novi Sign Ordinance to allow an additional 40.0 sq. ft. wall sign for a business within a multi-tenant office building. The property is located north of Twelve Mile Road and west of Haggerty Road.

Ordinance Sections:

CITY OF NOVI, CODE OF ORDINANCES, Section 28-5(3)f. allows a maximum of 1 sign for a multi-tenant business building unless a business has a separate entrance. The allowable second sign permitted under 28-5 (i) for buildings over 40,000 square feet, has already been utilized by another tenant.

City of Novi Staff Comments:

The applicant is requesting approval for an additional wall sign for a tenant within an existing office building. As the tenants share a common entrance, a single sign for the building is allowed by right with a second sign allowed if the building exceeds 40,000 square feet. The building already has (2) wall signs and a 3rd is proposed. Staff does not support the request as the failure to grant relief will not unreasonably prevent or limit the use of the property and will not result in substantially more than mere inconvenience or inability to attain a higher economic or financial return.

Standards for Granting a Sign Variance

- The request is based upon circumstances or features that are exceptional and unique to the property and do not result from conditions that exist generally in the City or that are self-created.
- The failure to grant relief will unreasonably prevent or limit the use of the property and will result in substantially more than mere inconvenience or inability to attain a higher economic or financial return.
- The grant of relief will not result in a use of structure that is incompatible with or unreasonably interferes with adjacent or surrounding properties, will result in substantial justice being done to both the applicant and adjacent or surrounding properties, and is not inconsistent with the spirit of the ordinance.

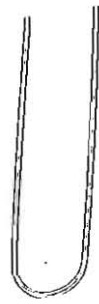
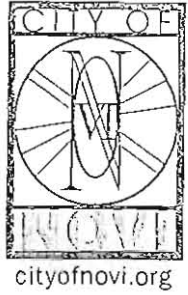

April 19, 2012

Townsend Sign Company
31550 Gossett Drive
Rockwood, Michigan 48173

RE: TIMKEN – 28125 CABOT DRIVE

The sign permit for the above location has been reviewed and DENIED.

Sign Code Section 28-5 (3)f. allows separately owned and operated businesses that occupy a building on a single parcel of land, each having a separate exterior entrance, a single identification wall sign.

This tenant does not have a separate exterior entrance.

Additional signage permitted under Section 28-5 (3) i: which allows a second sign for buildings over 40,000 square feet, has already been utilized by another tenant.

Should you wish to request consideration of a variance from the Zoning Board of Appeals, you may do so by contacting the board secretary, Angie Pawlowski, at 248-347-0459.

Please feel free to contact me at 248-347-0438 if you have any questions.

Sincerely,

CITY OF NOVI

Jeannie Niland
Ordinance Enforcement Officer



WEST ELEVATION

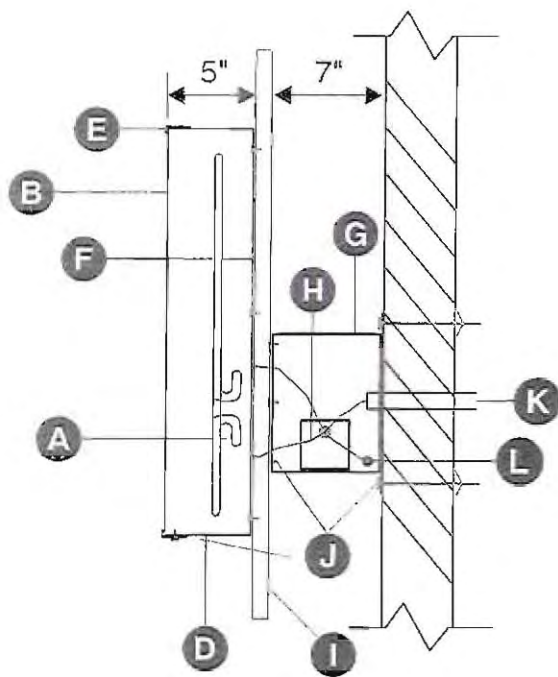

A	NEON	COLOR	QUANTITY	WHITE SHORT SLEEVE BOOTS OVER ELECTRODE
		WHITE	1 EA LETTER	
B	FACE	THICKNESS	COLOR	
		.125" ALUMINUM	PANTONE ORANGE 151C	
C	FONT	CUSTOM		
D	RETURN	DEPTH	COLOR	GAUGE
		5"	ORANGE	.063
E	RETAINER	SIZE	COLOR	TYPE
		1"	ORANGE	TRIM CAP
F	BACKS	MATERIAL	GAUGE	COLOR
		ALUMINUM	.125"	ORANGE
G	RACEWAY	SIZE	COLOR	MOUNTING
		7"x7"x143"	COOL GRAY 11	TOGGLE BOLTS
H	POWER SUPPLY	REMOTE TRANSFORMER IN TRANSFORMER BOX		
I	SIGN BACKING	SIZE	COLOR	
		1/8" ALUMINUM	COOL GRAY 11	
J	MOUNTING	INTERNAL	EXTERNAL	
		1/4" SELF DRIVING SCREWS	3/8" TOGGLE BOLTS	
K	CONDUIT	PRIMARY ELECTRICAL SOURCE NEC 500.4 & 500.71 (2) 3/2 & (1) 1/2 - 125 W 1/2" CONDUIT		
L	SWITCH	NEC 110-3(b), 560.2, 560.4, 500.5		

CANTON SIGN CO.
 • Since 1910 •
 Phone (330) 456-7151 Mailing ADDRESS:
 Fax (330) 456-7152 PO Box 80137
 E-mail: cantonsign@aol.com CANTON, OHIO 44708

CUSTOMER: **Timken Novi**

PHONE:

Fax:

DATE: **3-31-2012**

eMail:

31550 Gosset Drive
 Rockwood MI 48173
 734.379.4000
 info@TownsendSign.com
 www.TownsendSign.com



**SIGNS
 LIGHTING
 GRAPHICS**

**TIMKEN
 28125 CABOT
 NOVI, MICHIGAN**