



ROSE SENIOR LIVING AT PROVIDENCE JSP13-81

Rose Senior Living at Providence JSP13-81

Public hearing at the request of Edward Rose and Sons for recommendation to the City Council for approval of a revised Planned Suburban Low-Rise (PSLR) Overlay Development Agreement application and revised Concept Plan, and conditional approval of the Preliminary Site Plan. The property is located on the west side of Beck Road north of Eleven Mile Road. The applicant is proposing to add a seven-bay garage building to the west side of the property which is currently being developed as a 182 unit senior living facility with both congregate care and assisted living accommodations.

Required Action

Recommend approval/denial of the Revised Planned Suburban Low-Rise (PSLR) Overlay Concept Plan, and conditional approval of Preliminary Site Plan (subject to City Council's approval of the revised Concept Plan and revised PSLR Agreement).

REVIEW	RESULT	DATE	COMMENTS
Planning	Approval recommended	06-13-16	City Council deviation to reduce the garage setback from the property line (30 feet required, ~ 22 feet 2 inches proposed) – staff supported
Engineering	Approval recommended	05-19-16	
Landscaping	Approval recommended	05-24-16	Items to be addressed on the Final Site Plan submittal
Façade	Approval recommended	06-13-16	Items to be addressed on the Final Site Plan submittal
Fire	Approval recommended	05-20-16	Items to be addressed on the Final Site Plan submittal

Motion Sheet

Approval – PSLR Overlay Revised Concept and Preliminary Site Plan

In the matter of Rose Senior Living at Providence, JSP13-81, motion to **recommend approval** of the Revised Concept Plan and to conditionally approve the Preliminary Site Plan (pending City Council's action to approve the Revised Concept Plan and Revised PSLR Overlay Agreement) based on the following findings, City Council deviations, and conditions:

- a. The PSLR Overlay Development Agreement and PSLR Overlay Concept Plan will result in a recognizable and substantial benefit to the ultimate users of the project and to the community;
- b. In relation to the underlying zoning or the potential uses contemplated in the City of Novi Master Plan, the proposed type and density of the use will not result in an unreasonable increase in the use of public services, facilities and utilities, and will not place an unreasonable burden upon the subject property, surrounding land, nearby property owners and occupants, or the natural environment;
- c. In relation to the underlying zoning or the potential uses contemplated in the City of Novi Master Plan, the proposed development will not cause a negative impact upon surrounding properties (*as the proposed garage has been substantially buffered by existing and created natural features and should minimally impact the surrounding properties*);
- d. The proposed development will be consistent with the goals and objectives of the City of Novi Master Plan, and will be consistent with the requirements of the PSLR regulations (*as the proposed development meets the stated intent of the PSLR Overlay District to encourage transitional uses between higher intensity office and retail uses and lower intensity residential uses while maintaining the residential character of the area as outlined in the planning review letter*);
- e. City Council deviation for the following (*as the Concept Plan provides substitute safeguards for each of the regulations and there are specific, identified features or planning mechanisms deemed beneficial to the City by the City Council, which are designed into the project for the purpose of achieving the objectives for the District as stated in the Planning Review Letter*):
 1. City Council approval of a deviation of the ordinance standards to reduce the setback of the proposed garage from the property line (30 feet required, approximately 22 feet 2 inches provided);
- f. The findings of compliance with Ordinance standards in the staff and consultant review letters and the conditions and the items listed in those letters being addressed on the Final Site Plan; and
- g. (*additional conditions here if any*)

This motion is made because the plan is otherwise in compliance with the approved PSLR Overlay Agreement and PSLR Overlay Concept Plan, Section 3.1.27, Section 4.19, Section 4.20, Section 4.70, Section 4.73, Article 5.0, Article 6.0, and all other applicable provisions of the Ordinance.

-OR-

Denial

In the matter of Rose Senior Living at Providence, JSP13-81 motion to **recommend denial** of the Revised Concept Plan, for the following reasons... (because the plan is not in compliance with the approved PSLR Overlay Agreement and PSLR Overlay Concept Plan and Section 3.1.27, Section 4.19, Section 4.20, Section 4.70, Section 4.73, Article 5.0, and Article 6.0 of the Zoning Ordinance.)

Maps
Location
Zoning
Future Land Use
Natural Features

Rose Senior Living at Providence JSP13-81

Location



Map Legend

 Subject Property



1 inch = 318 feet



City of Novi
Planning Division
Community Development Dept.
45175 W Ten Mile Rd
Novi, MI 48375
cityofnovi.org

Map Author: Kristen Kapelanski
Date: 03-31-14
Project: Rose Senior Living JSP13-81
Version #: 1.0

MAP INTERPRETATION NOTICE

Map information depicted is not intended to replace or substitute for any official or primary source. This map was intended to meet National Map Accuracy Standards and use the most recent, accurate sources available to the people of the City of Novi. Boundary measurements and area calculations are approximate and should not be construed as survey measurements performed by a licensed Michigan Surveyor as defined in Michigan Public Act 132 of 1970 as amended. Please contact the City GIS Manager to confirm source and accuracy information related to this map.

Rose Senior Living at Providence JSP13-81

Zoning

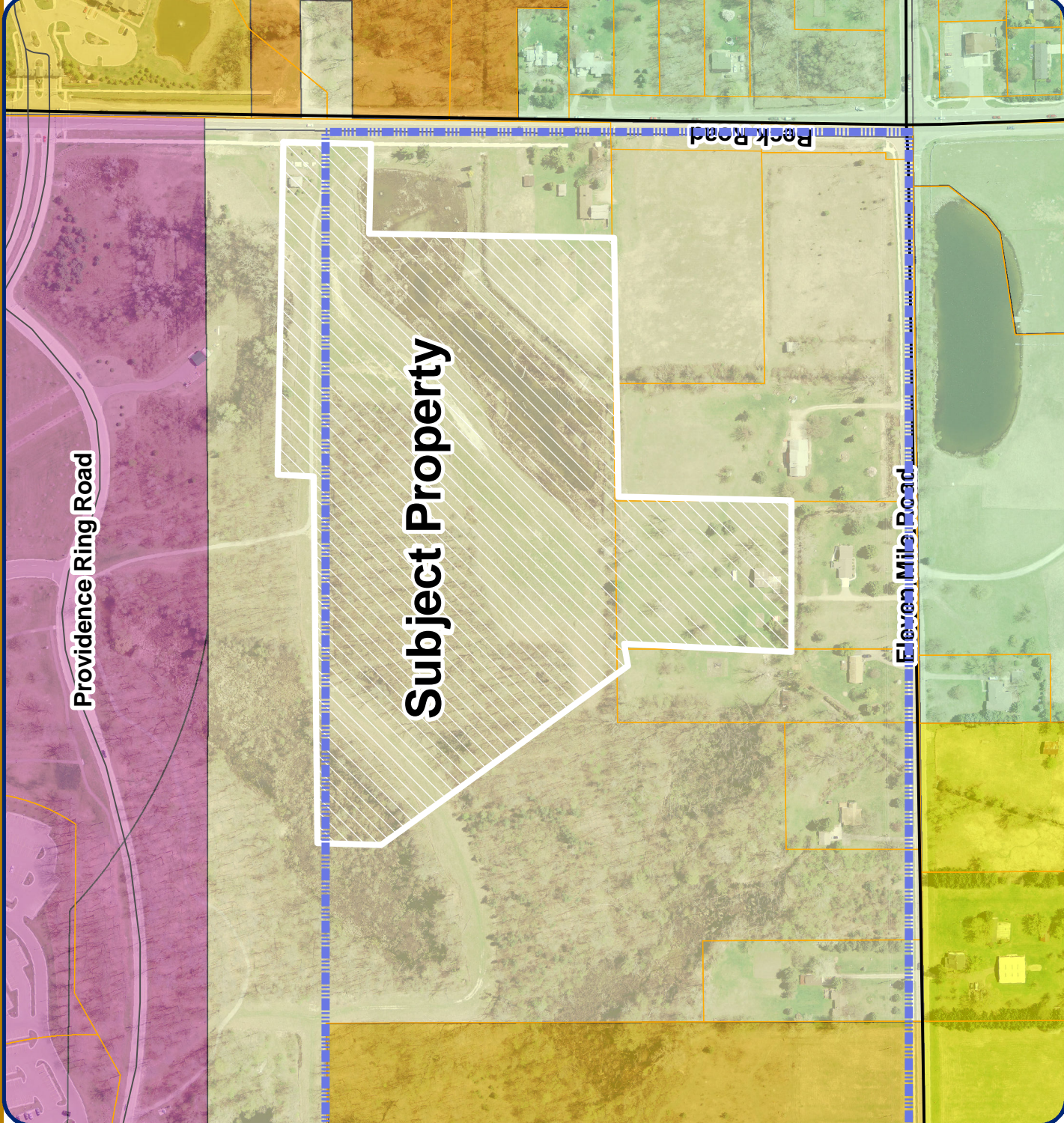

Map Legend

- Subject Property
- PSLR Overlay
- R-A: Residential Acreage
- R-3: One-Family Residential District
- R-4: One-Family Residential District
- RM-1: Low-Density Multiple Family
- RM-2: High-Density Multiple Family
- OSC: Office Service Commercial



City of Novi
 Planning Division
 Community Development Dept.
 45175 W Ten Mile Rd
 Novi, MI 48375
cityofnovi.org

Map Author: Kristen Kapelanski
 Date: 03-31-14
 Project: Rose Senior Living JSP13-81
 Version #: 1.0

MAP INTERPRETATION NOTICE





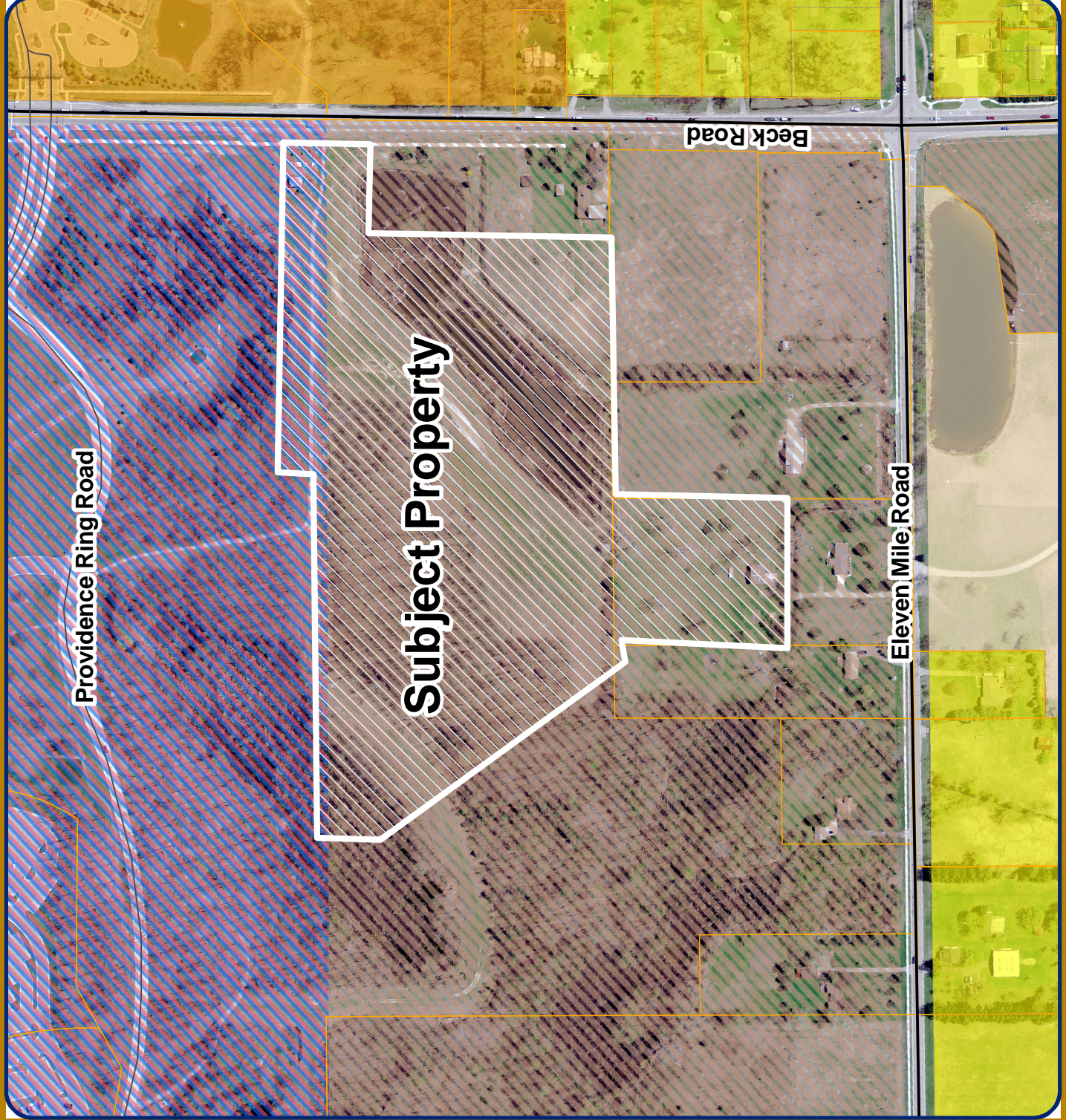

Map information depicted is not intended to replace or substitute for any official or primary source. This map was intended to meet National Map Accuracy Standards and use the most recent, accurate sources available to the people of the City of Novi. Boundary measurements and area calculations are approximated and should not be construed as survey measurements performed by a licensed Michigan Surveyor as defined in Michigan Public Act 132 of 1970 as amended. Please contact the City GIS Manager to confirm source and accuracy information related to this map.

Rose Senior Living at Providence JSP13-81

Future Land Use



Map Legend

-  Subject Property
-  Single Family
-  Multiple Family
-  PSLR
-  Office Commercial
-  Educational



City of Novi
 Planning Division
 Community Development Dept.
 45175 W Ten Mile Rd
 Novi, MI 48375
cityofnovi.org

Map Author: Kristen Kapelanski
 Date: 03-31-14
 Project: Rose Senior Living JSP13-81
 Version #: 1.0

MAP INTERPRETATION NOTICE

Map information depicted is not intended to replace or substitute for any official or primary source. This map was intended to meet National Map Accuracy Standards and use the most recent, accurate sources available to the people of the City of Novi. Boundary measurements and area calculations are approximate and should not be construed as survey measurements performed by a licensed Michigan Surveyor as defined in Michigan Public Act 132 of 1970 as amended. Please contact the City GIS Manager to confirm source and accuracy information related to this map.

Rose Senior Living at Providence JSP13-81

Natural Features



Map Legend

	Subject Property
	Wetlands
	Woodlands



City of Novi
 Planning Division
 Community Development Dept.
 45175 W Ten Mile Rd
 Novi, MI 48375
cityofnovi.org

Map Author: Kristen Kapelanski
 Date: 03-31-14
 Project: Rose Senior Living JSP13-81
 Version #: 1.0

MAP INTERPRETATION NOTICE

Map information depicted is not intended to replace or substitute for any official or primary source. This map was intended to meet National Map Accuracy Standards and use the most recent, accurate sources available to the people of the City of Novi. Boundary measurements and area calculations are approximate and should not be construed as survey measurements performed by a licensed Michigan Surveyor as defined in Michigan Public Act 132 of 1970 as amended. Please contact the City GIS Manager to confirm source and accuracy information related to this map.

Site Plan

(Full plan set available for viewing at the Community Development Department.)

ROSE SENIOR LIVING

at Providence Park

HRC 100 YEARS
CONSULTING ENGINEERS SINCE 1915

WARREN W. HARRIS
REGISTERED PROFESSIONAL ENGINEER
PHONE: 410-336-6000
FAX: 410-336-6001
410-336-6002
WWW.HRC100.COM

NO.	DESCRIPTION	DATE	STATUS
1	CONCEPT PLAN	10/1/14	APPROVAL
2	PRELIMINARY SITE PLAN	11/1/14	APPROVAL
3	PRELIMINARY CONSTRUCTION PLAN	12/1/14	APPROVAL
4	CONCEPT PLAN	1/1/15	APPROVAL
5	PRELIMINARY SITE PLAN	2/1/15	APPROVAL
6	PRELIMINARY CONSTRUCTION PLAN	3/1/15	APPROVAL
7	CONCEPT PLAN	4/1/15	APPROVAL
8	PRELIMINARY SITE PLAN	5/1/15	APPROVAL
9	PRELIMINARY CONSTRUCTION PLAN	6/1/15	APPROVAL
10	CONCEPT PLAN	7/1/15	APPROVAL
11	PRELIMINARY SITE PLAN	8/1/15	APPROVAL
12	PRELIMINARY CONSTRUCTION PLAN	9/1/15	APPROVAL
13	CONCEPT PLAN	10/1/15	APPROVAL
14	PRELIMINARY SITE PLAN	11/1/15	APPROVAL
15	PRELIMINARY CONSTRUCTION PLAN	12/1/15	APPROVAL
16	CONCEPT PLAN	1/1/16	APPROVAL
17	PRELIMINARY SITE PLAN	2/1/16	APPROVAL
18	PRELIMINARY CONSTRUCTION PLAN	3/1/16	APPROVAL
19	CONCEPT PLAN	4/1/16	APPROVAL
20	PRELIMINARY SITE PLAN	5/1/16	APPROVAL
21	PRELIMINARY CONSTRUCTION PLAN	6/1/16	APPROVAL
22	CONCEPT PLAN	7/1/16	APPROVAL
23	PRELIMINARY SITE PLAN	8/1/16	APPROVAL
24	PRELIMINARY CONSTRUCTION PLAN	9/1/16	APPROVAL
25	CONCEPT PLAN	10/1/16	APPROVAL
26	PRELIMINARY SITE PLAN	11/1/16	APPROVAL
27	PRELIMINARY CONSTRUCTION PLAN	12/1/16	APPROVAL
28	CONCEPT PLAN	1/1/17	APPROVAL
29	PRELIMINARY SITE PLAN	2/1/17	APPROVAL
30	PRELIMINARY CONSTRUCTION PLAN	3/1/17	APPROVAL

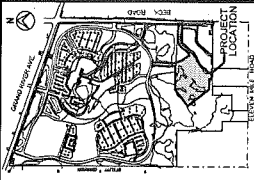

ROSE SENIOR LIVING AT PROVIDENCE PARK
CITY OF NOVI

PROPOSED SITE PLAN - ENLARGED -

NOVI, MI 48242
DATE: FEBRUARY 2016
SCALE: 1" = 40'-0"
SHEET: C 02

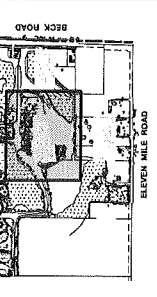
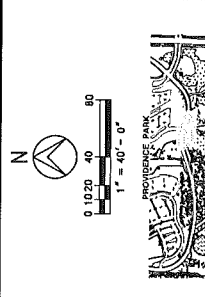

- UNIT MIX**
- 69 CONGREGATE CARE / INDEPENDENT LIVING UNITS
 - 75 ASSISTED LIVING UNITS (81 BEDS)
 - 38 MEMORY CARE UNITS (58 BEDS)
 - 182 TOTAL UNITS (PLUS 2 GUEST ROOMS)

- REQUIRED PARKING**
- 119 ASSISTED LIVING / MEMORY CARE BEDS
 - 30 - PARKING SPACES REQUIRED
 - 69 CONGREGATE LIVING UNITS
 - 52 - PARKING SPACES REQUIRED
 - 65 PEAK NUMBER OF GUEST VEHICLES
 - 65 - PARKING SPACES REQUIRED
 - 147 TOTAL PARKING SPACES REQUIRED
 - 186 TOTAL PARKING SPACES PROVIDED

*NO CURBS OR CURBS ALLOWING A CURB, BUMPER BLOCK, OR A RAISED SIDEWALK ARE TO BE NEAR FACE OF CURB, BLOCK, OR WALK. ALL OTHER DIMENSIONS ARE TO BACK OF CURB UNLESS OTHERWISE INDICATED.

NOTE: EMERGENCY ACCESS GATE IS TO BE INSTALLED AND CLOSED PRIOR TO ISSUANCE OF TCO FOR THE PROPOSED BUILDING.

LEGEND

[Symbol]	EXISTING PAVEMENT
[Symbol]	EXISTING GRAVEL
[Symbol]	EXISTING BUILDINGS
[Symbol]	PROPOSED 2.0' CONCRETE PAVEMENT
[Symbol]	PROPOSED 2.0' CONCRETE CURB AND GUTTER - 4" HIGH
[Symbol]	PROPOSED SIDEWALK
[Symbol]	PROPOSED RETAINING WALL
[Symbol]	PROPOSED CONCRETE PAVEMENT (COMPUTER PAV)
[Symbol]	PROPOSED CONCRETE SIDEWALK
[Symbol]	CITY OF NOVI STANDARD PAVEMENT
[Symbol]	PROPOSED BITUMEN PAVEMENT
[Symbol]	PROPOSED GRAVEL
[Symbol]	PROPOSED 4" HIGH CONCRETE PAVEMENT
[Symbol]	PROPOSED 4" HIGH CONCRETE PAVEMENT (EXHIBITOR PAD AND SERVICE AREA)
[Symbol]	PROPOSED 4" HIGH YELLOW PAINT MARK

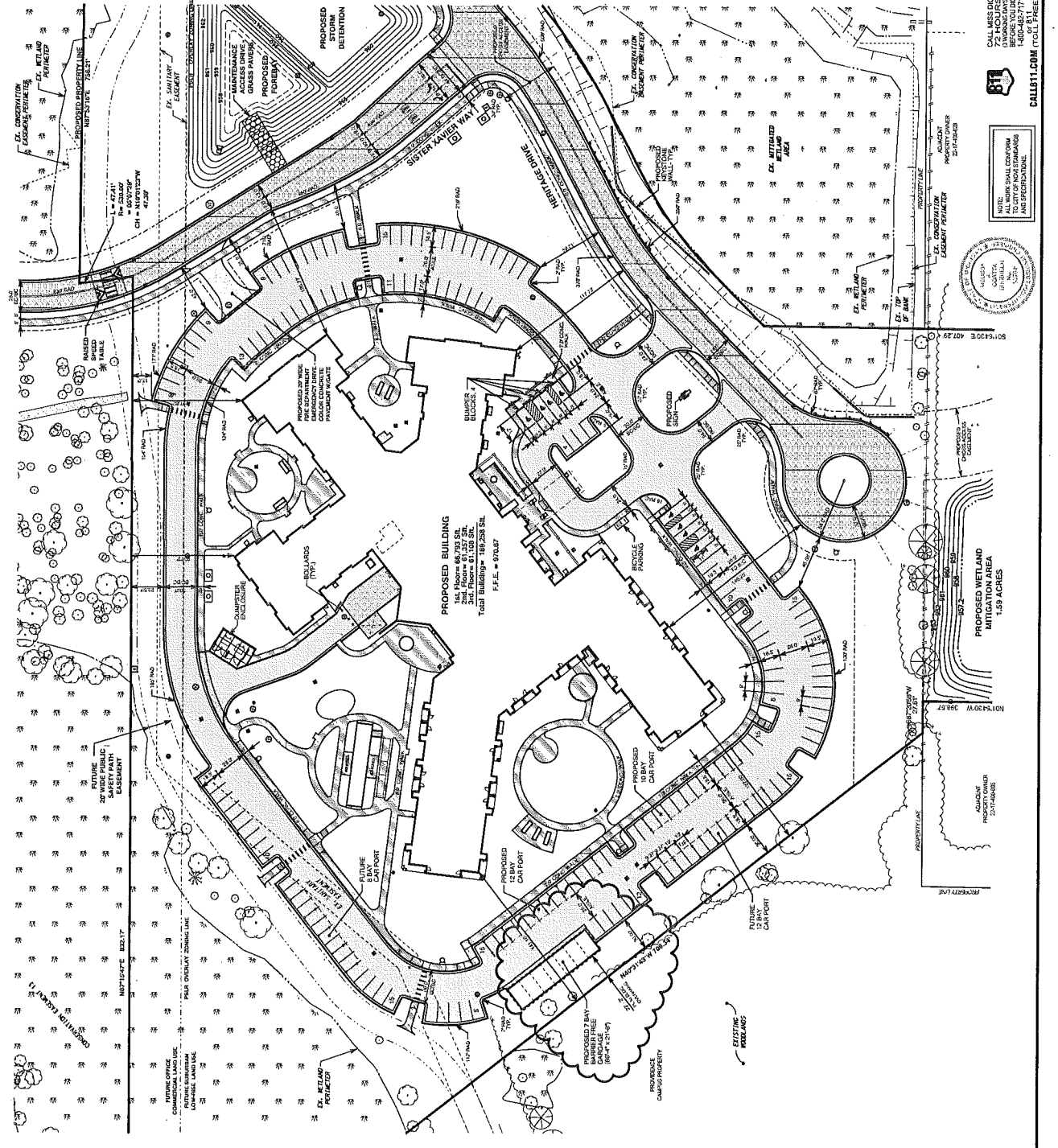

Copyright © 2018
 CONCEPT
 ASSOCIATES, INC.
 All rights reserved. No part of this document may be reproduced or transmitted in any form or by any means, electronic, mechanical, photocopying, recording, or by any information storage and retrieval system, without the prior written permission of CONCEPT ASSOCIATES, INC.
 See Title Sheet for more info.

Drawn by
 8-15-18
 Checked for
 City Number

Drawn by
 8-15-18
 Checked for

Project
 7 Bay Barrier Free Garage
 Tose Senior Living
 Tacking Garages
 Novi, Michigan
 Building Elevations

Sheet No.
 16023 A2
 Date
 08/15/18

Scale
 1/4" = 1'-0"

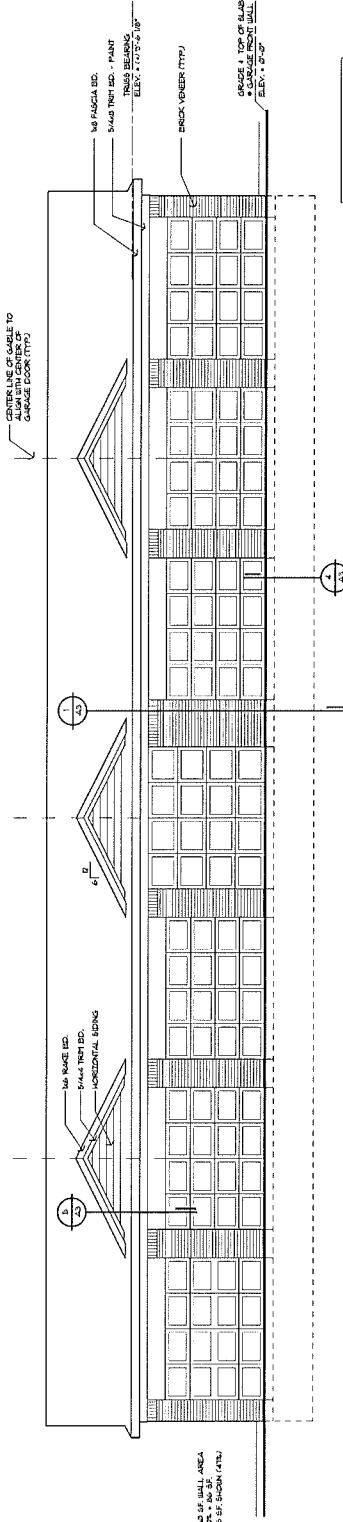
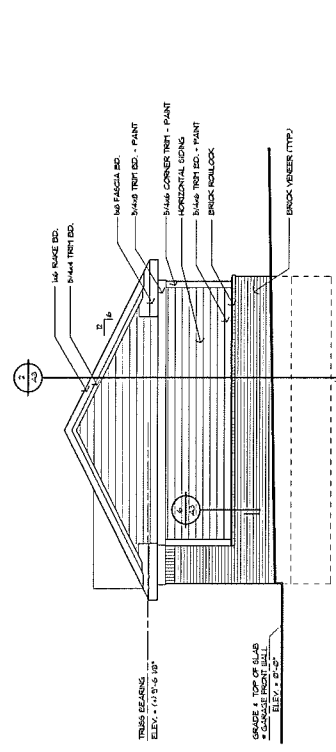
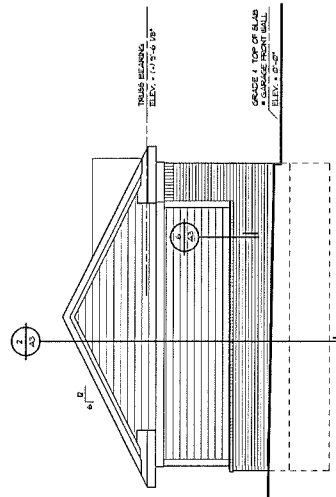
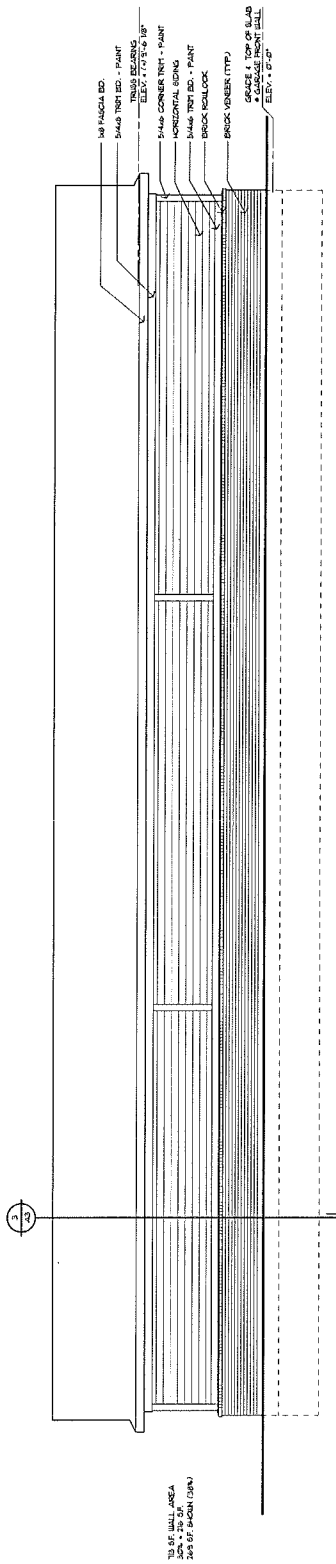

TOTAL WALL AREA = 1,071 SF
 BRICK SHOWN = 544 SF (51%)



CONCEPT ASSOCIATES, INC.
 2800 Grandville Road, Suite 107
 Grandville, Michigan 49431
 Tel: (616) 327-0222
 Fax: (616) 327-0221

FACADE COLOR SAMPLE BOARD



SIGN
PRECAST STONE



SIDING: FIBER CEMENT
COLOR: KILIM BEIGE



TRIM: COMPOSITE
COLOR: DOVER WHITE



ROOF: DIMENSIONAL ASPHALT SHINGLES
COLOR: WEATHERED WOOD



BRICK
COLOR: SHADE 488



MANUFACTURED STONE
COLOR: FAWN RIVER

Planning Review

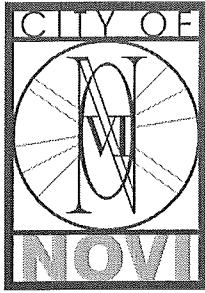

PLAN REVIEW CENTER REPORT

June 13, 2016

Planning Review

Rose Senior Living Garage at Providence

JSP13-81

Petitioner

Edward Rose and Sons

Review Type

Revised Concept and Preliminary Site Plan

Property Characteristics

- Site Location: North side of Eleven Mile Road and west of Beck Road (Section 17)
- Site Zoning: R-3 with PSLR Overlay
- Adjoining Zoning: North: R-3, One-Family Residential; East: R-3 with PSLR Overlay; West: R-3 with PSLR; South (across Eleven Mile Road): RA, Residential Acreage
- Current Site Use: Single-Family Residential
- Adjoining Uses: North: Vacant and Providence Hospital Maintenance Building; East, West and South: Single-Family Residential/Vacant
- School District: Novi Community School District
- Proposed Site Size: 20.71 acres
- Plan Date: 05-03-16

Project Summary

On May 19, 2014 the applicant received final approval from City Council for a Planned Suburban Low-Rise Overlay (PSLR) Development Agreement and Concept Plan for a 182 unit senior living facility. The facility will have both congregate care units as well as assisted living units. Recreation features for the residents are proposed along with associated site infrastructure and landscaping. An easement is being offered for the anticipated public trail connection from Beck Road through the site. The applicant is now returning with a revised Concept and Preliminary Site Plan to convert a portion of a parking bay to a seven car garage.

Recommendation

Staff recommends approval of the Revised Concept and Preliminary Site Plan to allow for the development of a seven bay garage, and supports a variance to allow for a deviation from the minimum required setback of 30' from the property line. The City Council must approve the variance request.

Approved PSLR Development Agreement and Concept Plan

The City Council approved the PSLR Development Agreement and Concept Plan on May 19, 2014. The Planning Commission approved the Preliminary Site Plan, Woodland permit, Wetland permit, and Stormwater Management Plan on May 28, 2014. Amendments to the approved PSLR Agreement and Plan shall follow the same procedures as would a new application. This modification to add the garage will require review and approval by the Planning Commission and City Council.

PSLR Overlay Standards and Procedures

The PSLR Overlay District requires the approval of a PSLR Overlay Development Agreement and Concept Plan by the City Council following a public hearing and recommendation from the Planning Commission.

In making its recommendation to the City Council, the Planning Commission considered the following factors.

- a) The PSLR Overlay Development Agreement and PSLR Overlay Concept Plan will result in a

- recognizable and substantial benefit to the ultimate users of the project and to the community.
- b) In relation to the underlying zoning or the potential uses contemplated in the City of Novi Master Plan, the proposed type and density of use(s) will not result in an unreasonable increase in the use of public services, facilities and utilities, and will not place an unreasonable burden upon the subject property, surrounding land, nearby property owners and occupants, or the natural environment.
 - c) In relation to the underlying zoning or the potential uses contemplated in the City of Novi Master Plan, the proposed development will not cause a negative impact upon surrounding properties.
 - d) The proposed development will be consistent with the goals and objectives of the City of Novi Master Plan, and will be consistent with the requirements of this Article [Article 23B].

The City Council on April 22, 2014, after review of the Planning Commission's recommendation, consideration of the input received at the public hearing, and review of other information relative to the PSLR Overlay Development Agreement Application and PSLR Overlay Concept Plan, indicated its tentative approval of the PSLR Overlay Development Agreement Application and PSLR Overlay Concept Plan, and directed the City Administration and City Attorney to prepare, for review and approval by the City Council, a PSLR Overlay Development Agreement. The City Council then approved the PSLR Overlay Development Agreement and Concept Plan on May 19, 2014.

The applicant then proceeded with the standard site plan review and approval procedures outlined in Section 6.1.

Ordinance Deviations

Section 3.21.1 permits deviations from the strict interpretation of the Zoning Ordinance within a PSLR Overlay agreement. These deviations can be granted by the City Council on the condition that *"there are specific, identified features or planning mechanisms deemed beneficial to the City by the City Council which are designed into the project for the purpose of achieving the objectives for the District."* The applicant shall provide substitute safeguards for each item that does not meet the strict requirements of the Zoning Ordinance. For ordinance deviations related to this project, please reference earlier Planning review letters and the approved PSLR development agreement.

Ordinance Requirements

For this review letter, only the proposed seven bay garage was reviewed for conformance with Section 3.1.27 (Planned Suburban Low-Rise Overlay District), Section 3.21 (PSLR Required Conditions), Section 4.19 (Accessory Uses), Section 4.20 (Housing for the Elderly), Section 4.70 (Low-Rise Multiple-Family Residential Uses in the PSLR District), Section 4.73 (Accessory Buildings, Structures, and Uses in the PSLR District), Article 5.0 (Site Standards), Article 6.0 (Development Procedures) and any other applicable provisions of the Zoning Ordinance. Items in **bold** below must be addressed by the applicant.

1. **Setbacks: The proposed seven bay garage is located 22'-2" from the property line. The minimum required setback is 30'. Staff supports approval of a variance to allow for a deviation from the minimum required setback of 30' from the property line.** The maneuvering aisle is currently 26' wide with an additional 4' wide area to transition between the garage and aisle. The Zoning Ordinance requires a 24' wide maneuvering aisle; however, the applicant states that the 26' wide drive aisle is necessary for fire truck access, and the additional 4' wide concrete strip is required in order to transition the cross-slope of the drive aisle to the flat garage entrance.

All department comments were received for the revised concept and preliminary site plan by June 13, 2016.

In a review letter dated May 19, 2016 the City Engineer recommends approval of the revised Concept and Preliminary Site Plan, and Preliminary Storm Water Management Plan for the seven bay garage.

In a review letter dated May 24, 2016 the City's Landscape Architect recommends approval of the revised Concept and Preliminary Site Plan. Review letter comments regarding transplantation of existing plantings are not applicable because no plantings have been installed.

In a review letter dated June 13, 2016 the City's Façade Consultant states that the applicant has revised the design to provide brick extending to the frieze line on the front façade, and that the design now achieves full compliance with the Façade Ordinance on all facades.

The City's Fire Marshal states in a letter dated May 20, 2016 that they recommend approval of the revised Concept and Preliminary Site Plan for the seven bay garage.

Pre-Construction Meeting

Prior to the start of any work on the site, Pre-Construction (Pre-Con) meetings must be held with the applicant's contractor and the City's consulting engineer. Pre-Con meetings are generally held after Stamping Sets have been issued and prior to the start of any work on the site. There are a variety of requirements, fees and permits that must be issued before a Pre-Con can be scheduled. If you have questions regarding the checklist or the Pre-Con itself, please contact Sarah Marchioni [248.347.0430 or smarchioni@cityofnovi.org] in the Community Development Department.

Chapter 26.5

Chapter 26.5 of the City of Novi Code of Ordinances generally requires all projects be completed within two years of the issuance of any starting permit. Please contact Sarah Marchioni at 248-347-0430 for additional information on starting permits. The applicant should review and be aware of the requirements of Chapter 26.5 before starting construction.

Response Letter

A letter from either the applicant or the applicant's representative addressing comments in this and other review letters is required with the next plan submittal.

If the applicant has any questions concerning the above review or the process in general, do not hesitate to contact me at 248.347.0586 or ajordan@cityofnovi.org.

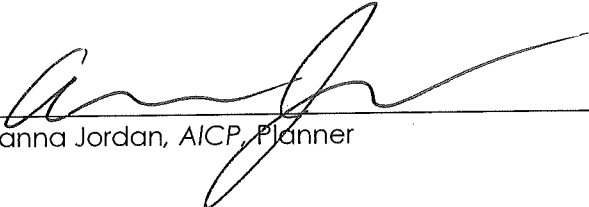

Adrianna Jordan, AICP, Planner

Engineering Review

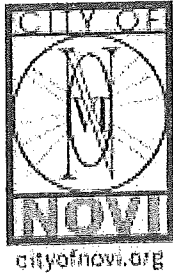

PLAN REVIEW CENTER REPORT

05/19/2016

Engineering Review

ROSE SENIOR LIVING AT PROVIDENCE PARK
JSP13-0081

Applicant

PROVIDENCE HOSPITAL

Review Type

Revised Concept and Preliminary Site Plan

Property Characteristics

- Site Location: S, of Grand River Ave. and W. of Beck Rd.
- Site Size: 20.71 acres
- Plan Date: 05/03/16

Project Summary

- Construction of an approximately 7 garages southwest of the building in place of parking spaces shown on the previously approved plan.

Recommendation

Approval of the Revised Concept and Preliminary Site Plan and Preliminary Storm Water Management Plan is recommended. No further engineering submittal is required.

Comments:

The Preliminary Site Plan meets the general requirements of Chapter 11, the Storm Water Management Ordinance and the Engineering Design Manual.

To the extent this review letter addresses items and requirements that require the approval of or a permit from an agency or entity other than the City, this review shall not be considered an indication or statement that such approvals or permits will be issued.

Please contact Jeremy Miller at (248) 735-5694 with any questions.

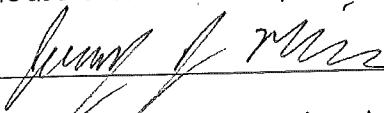

cc: Adam Wayne, Engineering
Brian Coburn, Engineering
Adrianna Jordan, Community Development
Sabrina Lilla, Water & Sewer

Landscape Review

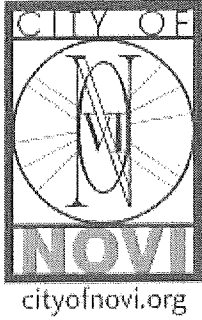

PLAN REVIEW CENTER REPORT
May 24, 2016
Revised Concept Plan Plan - Landscaping
Rose Senior Living

Review Type
Revised Concept Plan Landscape Review

Project Number
JSP13-0081

Property Characteristics

- Site Location: South of Providence Hospital, fronting on Beck Road
- Site Zoning: RM-4/PSLR
- Plan Date: 5-3-2016

Ordinance Considerations

This project was reviewed for conformance with Chapter 37: Woodland Protection, Zoning Article 5.5 Landscape Standards, the Landscape Design Manual and any other applicable provisions of the Zoning Ordinance. This review is a summary and not intended to substitute for any Ordinance.

Recommendation

This project is **recommended for approval**.

The conversion of part of a parking bay to a covered garage does not require any additional landscaping. No existing trees are being removed or impacted by this project and the only change is some rearrangement of previously proposed trees near the garage. The proposed modifications are satisfactory.

If those plantings have already been installed in the originally proposed locations, please follow these guidelines during their transplanting to the new locations:

Transplanted material guidelines (from Landscape Design Manual)

3.f. Collected or Transplanted Trees

1. All collected trees shall be from on-site and inspected by the City. Trees may be rejected for reasons of insect infestation, disease or standards set forth in this ordinance. Such plant material may be rejected either in full or in part.
2. All transplanted trees shall conform to standards set forth in Section 3c.
3. The root ball of any transplanted tree shall measure 1 foot for each inch of trunk diameter measured 12" above the ground.
4. If trees are to be stored, they shall be burlapped and heeled in with mulch in a pre-determined area approved by the City.
5. The trees shall be provided with a working irrigation system approved by the City to ensure their viability during storage.

If the applicant has any questions concerning the above review or the process in general, please do not hesitate to contact me at 248.735.5621 or rmeader rmeader@cityofnovi.org.

Rick Meader – Landscape Architect

Facade Review



Phone: (248) 880-6523
 E-Mail: dnecci@drnarchitects.com
 Web: drnarchitects.com

DRN & ASSOCIATES, ARCHITECTS, PC

50850 Applebrooke Dr., Northville, MI 48167

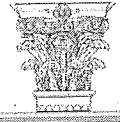

June 13, 2016

City of Novi Planning Department
 45175 W. 10 Mile Rd.
 Novi, MI 48375-3024

Façade Review Status Summary:
Approved, qualifies for administrative approval.

Re: **FACADE ORDINANCE - Façade Review**
Rose Senior Living Garage Addition, PSP16-0053
 Façade Region: 1, Zoning District: R-3

Dear Ms. McBeth;

The following is the Façade Review for the above referenced project based on the drawings prepared by Dorchen Martin Architects, dated 6/13/16. This project is subject to the Façade Ordinance Section 5.15 as well as the Suburban Low-Rise Overlay Ordinance Section 3.21.C. The percentages of materials proposed for each façade are as shown in the tables below. Materials in non-compliance, if any, are highlighted in bold.

Garages	Front	Rear	Rt. Side	Lt. Side	Façade Ordinance Section 2520 Maximum (Minimum)
Brick	30%	30%	35%	35%	100% (30% Min)
Asphalt Shingles	50%	40%	0%	0%	25%
Wood Trim	10%	10%	15%	15%	15%
Horizontal Siding	20%	30%	50%	50%	50% (Note 11)

Section 2520 – The applicant has revised the design to provide brick extending to the frieze line on the front façade (see attached). A sample board has been provided that indicates that the materials will match those used on the primary building. With this revision the design is in full compliance with the Façade Ordinance on all facades. This application therefore qualifies for administrative approval in accordance with Section 6.1.1.c.x. of the Zoning Ordinance, provided that all other requirements for administrative approval are met.

Section 2305B - With respect to Ordinance 2305B, the design exhibits “single family residential character” and otherwise complies with all requirements of this Section.

Notes to the Applicant:

1. Façade Ordinance requires inspection(s) for all projects. Materials displayed on the approved sample board will be compared to materials delivered to the site. It is the applicant's responsibility to request the inspection of each façade material at the appropriate time. Inspections may be requested using the Novi Building Department's Online Inspection Portal with the following link. Please click on "Click here to Request an Inspection" under "Contractors", then click "Façade".

<http://www.cityofnovi.org/Services/CommDev/OnlineInspectionPortal.asp>

If you have any questions regarding this project please do not hesitate to call.

Sincerely,
DRN & Associates, Architects PC

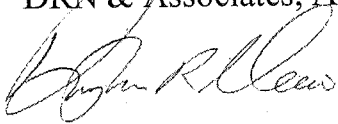

Douglas R. Necci, AIA

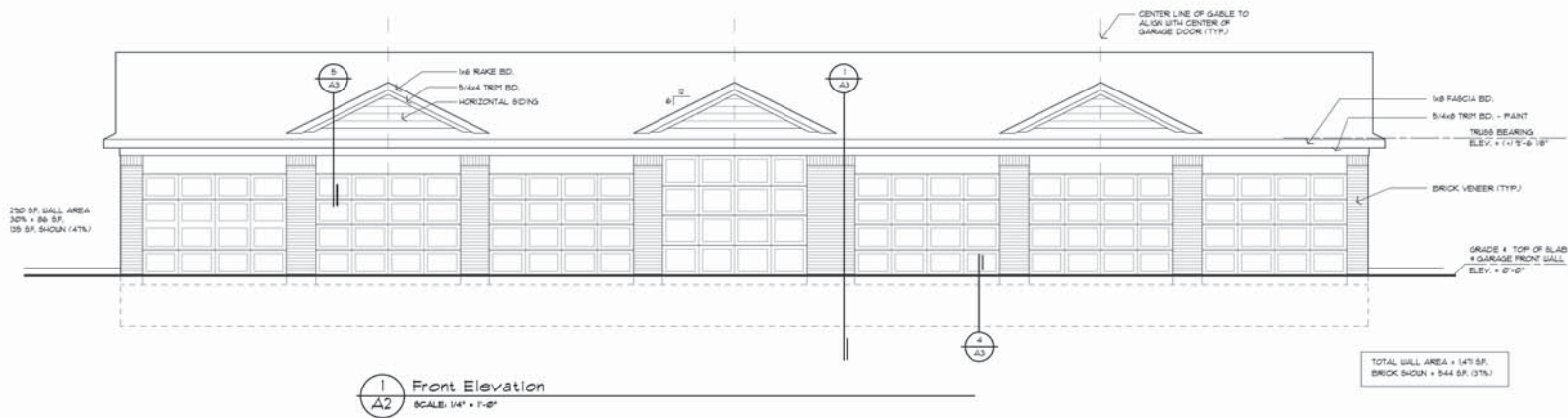
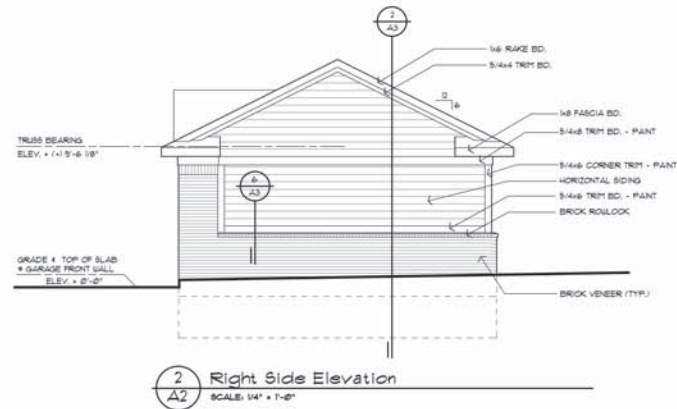
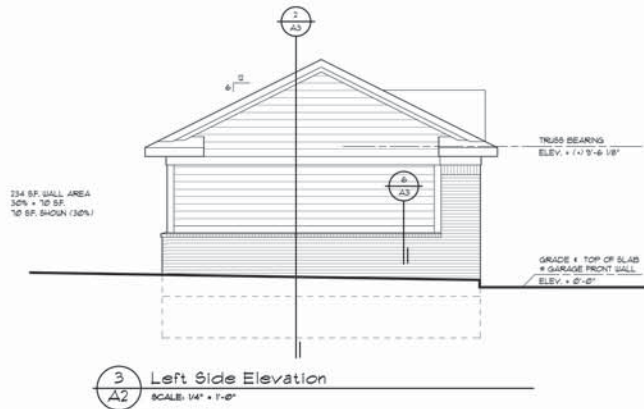
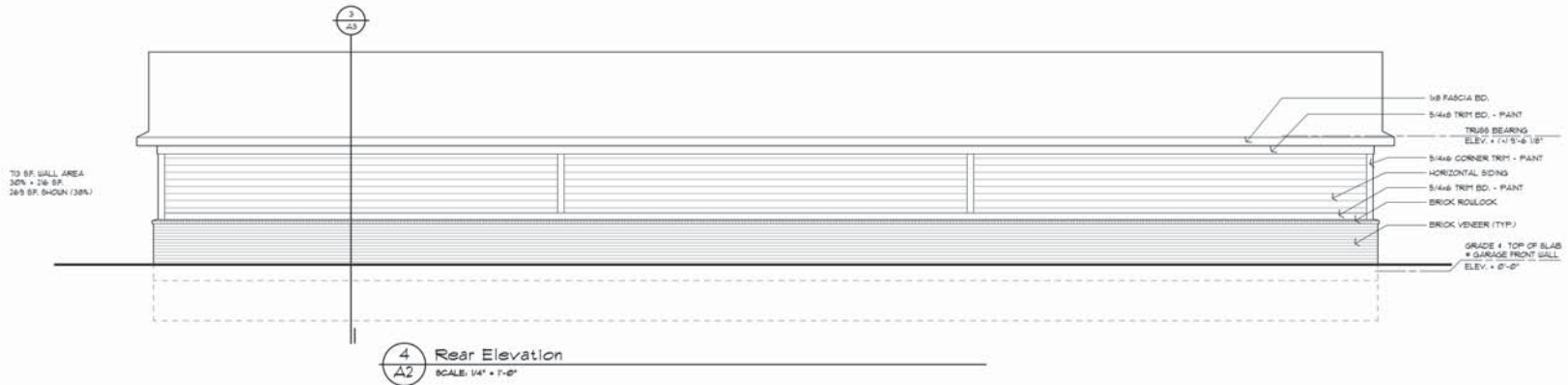

date	Issued for
5-13-18	Owner Review
5-13-18	City Review
revisions	

drawn by	checked by
Rose Senior Living Parking Garages Novi, Michigan	7 Bay Barrier-Free Garage Building Elevations
project	sheet title

DorchenMartin Associates, Inc.
 Architects/Planners
 29805 Greenfield Rd., Suite 107
 Southfield, Michigan 48078
 (248) 557-1062
 Fax: (248) 557-1231

Fire Review

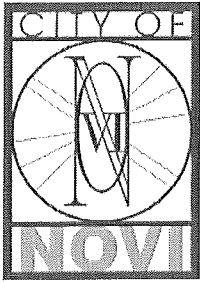

May 20, 2016

TO: Barbara McBeth- City Planner
Adrianna Jordan- Plan Review Center

RE: Rose Senior Living, Garage addition

PSP#16-0053

CITY COUNCIL

Mayor
Bob Gatt

Mayor Pro Tem
Dave Staudt

Gwen Markham

Andrew Mutch

Wayne Wrobel

Laura Marie Casey

Brian Burke

City Manager
Pete Auger

Director of Public Safety
Chief of Police
David E. Molloy

Director of EMS/Fire Operations
Jeffery R. Johnson

Assistant Chief of Police
Erick W. Zinser

Assistant Chief of Police
Jerrod S. Hart

Project Description: Addition of 7 bay garage on the west side of ring roadway.

Comments: Meets fire department standards

Recommendation: Approval

Sincerely,

Joseph Shelton- Fire Marshal
City of Novi – Fire Dept.

cc: file

Novi Public Safety Administration
45125 W. Ten Mile Road
Novi, Michigan 48375
248.348.7100
248.347.0590 fax

cityofnovi.org

Applicant Response Letter



June 8, 2016

City of Novi – Community Development
Attn: Adrianna Jordan, AIC, Planner
45125 W. Ten Mile Road
Novi, MI 48375
(248) 347-0475

ISP13-0081 Rose Senior Living Garage at Providence – Response Letter

Ms. Jordan,

In response to the **Planning Review** letter dated May 27, 2016, we have looked further for options to minimize the encroachment into the 30-foot setback. However, the 26-foot drive isles are needed for fire truck access and the additional 4-foot wide concrete strip is required in order to transition the cross-slope of the drive isle to the flat garage entrance. Being a senior facility, we need to make all slopes as gradual as possible. All other comments have been noted.

As for the **Landscape Review** letter dated May 24, 2016, no planting have been installed in the immediate or adjacent areas to the proposed garage location. All other comments have been noted for future landscape installation.

A revised garage plan has been submitted along with this response to address Mr. Necci's concern in his **Façade Review** letter dated May 26, 2016. We have provided the minimum of 30% brick coverage on all four (4) sides of the proposed garage. In this case, a Section 9 Waiver will not be required. All other comments have been noted.

Both the **Engineering Review** and **Fire Marshal Review** comments have been noted.

Feel free to contact me with any questions.

Thank You,

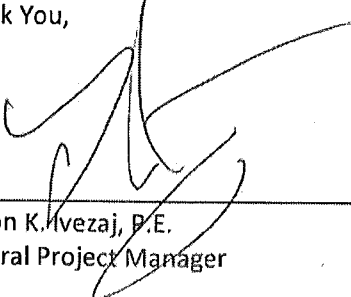

Lindon K. Ivezaj, P.E.
General Project Manager

PSLR Overlay Agreement

CITY OF NOVI
CITY CLERK'S OFFICE

2015 JUL -6 A 11:45

PLANNED SUBURBAN LOW-RISE (PSLR) OVERLAY
DEVELOPMENT AGREEMENT - PROVIDENCE
PARK SENIOR LIVING, LLC

THIS PLANNED SUBURBAN LOW-RISE (PSLR) OVERLAY DEVELOPMENT AGREEMENT (this "Agreement") is made as of the 8th day of JUNE, 2015, by and among PROVIDENCE PARK SENIOR LIVING, LLC, whose address is 38525 Woodward Ave., Bloomfield Hills, MI 48304, (herein referred to as "Developer"), PROVIDENCE HOSPITAL AND MEDICAL CENTERS, INC., whose address is 47601 Grand River Avenue, Novi, MI 48374 (herein referred to as "Land Owner"), and the CITY OF NOVI, whose address is 45175 West Ten Mile Road, Novi, MI 48375-3024 ("City").

RECITATIONS:

- I. Land Owner is the fee owner of the "Land" described on Exhibit A, attached and incorporated herein. The Land is one parcel of property approximately 20.71 acres in area as described in Exhibit A. Developer proposes to develop the Land, with the Land Owner's approval, as a senior living facility with a maximum size of 190,000 square feet and a maximum of 182 living units, including independent living/congregate care, assisted living, and memory care dwellings, plus two guest suites, with centralized dining, staff and facilities spaces, common spaces, and accessory uses (herein referred to as "Facility") as set forth in the PSLR Overlay Concept Plan, which has been submitted to the City for review and approval under applicable provisions of the City code, including the Zoning Ordinance. The PSLR Overlay Concept Plan as hereby approved is a conceptual or illustrative plan for the potential development of the Land under the PSLR Overlay District that includes building elevations and site improvements. Such Concept Plan approval is not an approval to construct any of the proposed improvements as shown. .
- II. Developer is the lessee and the Land Owner is the lessor of a 99-year term ground lease for the Land. The Developer will construct and control the proposed development on the Land, including the proposed Facility.
- III. For purposes of improving and using the 20.71-acre parcel for the Facility, Developer petitioned the City, with the Land Owner's authorization, to consider approval for the Facility under a PSLR Overlay Development

Agreement application that included a PSLR Overlay Concept Plan, dated February 18, 2014 and on file in the Community Development Office, a community impact statement, a traffic generation analysis, and proposed deviations and waivers.

- IV. The Land is zoned R-3 one-family residential, with a PSLR Overlay that covers the Land except for a small area on the north edge of the parcel. The PSLR Overlay zoning classification provides the Developer with certain material development options with respect to the Land that are not available under the R-3 one-family residential classification and that would be a distinct material benefit and advantage to the Developer. The PSLR Overlay zoning classification is consistent with the City's Master Plan for Land Use showing the Land as part of the future Suburban Low-Rise use.
- V. The City has reviewed the Developer's proposed petition to consider a PSLR Overlay Development Agreement application under the terms of the PSLR Overlay District provisions of the City's Zoning Ordinance; has reviewed the Developer's proposed PSLR Overlay Concept Plan, the Developer's community impact statement and traffic generation analysis, and the Developer's proposed deviations and waivers. The City has found that the PSLR Overlay Concept Plan meets the intent of the PSLR Overlay District ordinance.
- VI. In petitioning for consideration of a PSLR Development Agreement Application, Developer and Land Owner have expressed as a firm and unalterable intent that Developer will develop and use the Land, including the area outside the PSLR Overlay District, on the north edge of the parcel, in conformance with the following conditions, (herein referred to as the "Conditions"):
 - A. Developer shall develop and use the Land solely for the operation of the Facility. Developer and Land Owner shall forbear from developing and/or using the Land, including the area outside the PSLR Overlay District, on the north edge of the parcel, in any manner other than as authorized and/or limited by this Agreement.
 - B. Subject to the terms and conditions of this Agreement and the PSLR Overlay District ordinance, Article 23B, *et seq.*, of the Zoning Ordinance, Developer shall develop the Land in accordance with all applicable laws, ordinances, and regulations of the City pertaining to such development required under the PSLR Overlay District, including all applicable height, area, and bulk requirements of the Zoning Ordinance as relates to the PSLR Overlay District, except as expressly authorized herein.

The PSLR Overlay Concept Plan, is acknowledged and agreed by the City, Land Owner, and Developer to be a conceptual plan for the

purpose of depicting the general area contemplated for development on the Land. The Developer will be required to obtain site plan approval for the development of the improvements to be constructed on the Land (i.e., the Facility) in accordance with the terms of the PSLR Overlay District ordinance.

Some deviations and waivers from the provisions of the City's ordinances, rules, or regulations as to the Facility are depicted in the PSLR Overlay Concept Plan, as specifically described below, and are approved by virtue of this Agreement. However, except as to such specific deviations and waivers as enumerated herein, the development of the Land under the requirements of the PSLR Overlay District shall be subject to and in accordance with all applications, reviews, approvals, permits, and authorizations required under all applicable laws, ordinances, and regulations pertaining to such development, including, but not limited to, site plan approval, storm water management plan approval, woodlands and wetlands permits, facade approval, landscape approval, engineering plan approval and payment of review and inspection fees and performance guarantees pertaining to the proposed development of the Land.

The building design and layout, facade, and elevations shall be substantially similar to that submitted as part of the Developer's final approval request, as depicted in the PSLR Overlay Concept Plan, or as the same shall be approved by the City in connection with the site plan approval for the improvements to be constructed on the Land, it being acknowledged and agreed that the Concept Plan and final site plan may be modified if approved by the City.

Developer and Land Owner shall provide the following Public Benefits/Public Improvements in connection with the development of the Land:

(1) Woodland Replacement. Approximately 1,326 woodland replacement tree credits are required by the woodland ordinance. The PSLR Overlay Concept Plan shows approximately 1,147 woodland replacement tree credits through plantings, a portion of which are located outside of the regulated woodland area as depicted on Exhibit B, Woodland Replacement Plan. Any remaining required tree credits not provided for through plantings will be addressed by placing the appropriate monies into the City of Novi tree fund. The replacement trees shall not be removed and shall be provided and maintained in accordance with the woodland ordinance and the requirements of the Zoning Ordinance and any City approvals. The exact number of woodland replacement credits and any changes to the site with regard to woodland replacement tree credits are subject to review and final

determination and approval by the City in accordance with all applicable provisions of the City Code and Zoning Ordinance.

(2) Wetland Mitigation. The PSLR Overlay Concept Plan shows 2.86 acres of proposed wetland mitigation as depicted on Exhibit C, Proposed Site Plan Overall. The exact locations of the proposed wetland mitigation will be as further determined and approved by the City during the site plan approval process. The wetland mitigation areas shall not be removed and shall be provided and maintained in accordance with the wetlands and watercourse protection ordinance and the requirements of the Zoning Ordinance. The exact amount of wetland mitigation and any changes to the site with regard to wetland mitigation areas are subject to review and final determination and approval by the City in accordance with all applicable provisions of the City Code and Zoning Ordinance.

(3) Creation of a Conservation Easement. Land Owner and Developer shall place 2.86 acres of wetland mitigation areas in a perpetual conservation easement, in a form to be determined by the City. The exact locations of the proposed wetland mitigation areas will be further approved by the City during the site plan approval process. Land Owner and Developer shall also place the woodland areas depicted on the attached Exhibit D in a perpetual conservation easement, in a form to be determined by the City. The exact locations of the proposed woodland conservation areas will be further approved by the City during the site plan approval process.

(4) Dedication of City Path Easement. Land Owner and Developer shall agree to provide a 20 foot wide city path easement, in a form to be determined by the City, for the City to construct a path (the "City Path") through the Land that shall be open for public pedestrian use as shown on the PSLR Concept Plan and as further approved by the City during the site plan approval process.

(5) Limitations on Use. Developer and Land Owner hereby agree that the use of the Land shall be limited to the operation of the Facility.

(6) Limitations on Size. Developer and Land Owner hereby agree that the size of the Facility shall be limited to 190,000 square feet in area, and a maximum of 182 units, plus two guest suites.

VII. The parties acknowledge that this Agreement contains terms and conditions, which are binding on Developer and Land Owner.

NOW, THEREFORE, IT IS AGREED AS FOLLOWS:

1. Each and every provision, representation, term, condition, right, and obligation

set forth in Recitations I-VII is binding upon the parties of this Agreement and is incorporated as a part of this Agreement.

As provided in the PSLR Overlay District ordinance, Article 23B *et seq.* of the City's Zoning Ordinance:

- a. No use of the Land shall be allowed except the uses shown on the PSLR Overlay Concept Plan for the operation of the Facility. Site plan review for the development of the Land is required in accordance with the terms of the City's ordinances; provided, however, that modifications to the improvements to be constructed on the Land shall be permitted subject to the City's approval;
 - b. Developer and Land Owner and their successors, assigns, and/or transferees shall act in conformance with the PSLR Overlay Concept Plan and Conditions, including the provision of the Public Benefits/Public Improvements, all as described above and incorporated herein;
 - c. Developer and Land Owner and their successors, assigns, and/or transferees shall forbear from acting in a manner inconsistent with the PSLR Overlay Concept Plan and Conditions, and the Public Benefits/Public Improvements, all as described in the Recitations above and incorporated herein; and
 - d. Developer and Land Owner shall commence and complete all actions reasonably necessary to carry out the PSLR Overlay Concept Plan and all of the Conditions and Public Benefits/Public Improvements, all as described in the Recitations above and incorporated herein.
 - e. Developer and Land Owner consent to an extension of the PSLR Overlay District, if required by the City, to the area of the Land on the north edge of the parcel not currently subject to the overlay.
2. The following deviations and waivers from the standards of the City's Zoning Ordinance with respect to the Land are hereby authorized pursuant to Section 2304B of the City's Zoning Ordinance and as shown on the PSLR Overlay Concept Plan or final approved site plan:

(a) the permitted maximum building length of 180 feet shall be increased to 471 feet;

(b) the permitted maximum building height of 35 feet shall be increased to 41 feet;

(c) the permitted maximum 60 foot spacing of ground floor pedestrian entrance doors on all building elevations shall be waived;

(d) the permitted maximum asphalt shingle area between the eave and peak of the roof shall be waived to address the overage of the maximum use of asphalt shingles;

(e) off-street parking shall be permitted in the front yard (south) and the exterior side yard (east);

(f) the carports shall be permitted in the interior side yard (southwest);

(g) the two on-premises signs shall be permitted; one on-premises entranceway ground sign at Beck Rd. and one on-premises business ground sign in front of the Facility;

(h) full-time access to Beck Rd., a section line road, shall be permitted;

(i) a two to five foot tall undulating berm shall be permitted between the eastern proposed parking area and the proposed roadway;

(j) a one and one-half foot minimum to five foot tall maximum decorative wall fronting Beck Rd. shall be permitted in lieu the required 3 foot minimum to 5 foot maximum undulating berm; and

(k) the requirement of a 4 foot wide landscape bed around the entire building foundation is hereby waived.

3. Each of the provisions, requirements, deviations/waivers, and conditions in this Agreement and the features and components provided in the PSLR Overlay Concept Plan meet the intent of the PSLR Overlay District.

4. Developer and Land Owner acknowledge that, at the time of the execution of this Agreement, the Facility has not yet obtained site plan, engineering, and other approvals required by ordinance or other regulation. Developer and Land Owner acknowledge that the Planning Commission and Engineering Division may impose additional conditions other than those contained in this Agreement during site plan reviews and approvals as authorized by law; provided, however, that such conditions shall not be inconsistent with the PSLR Overlay Concept Plan and this Agreement and shall not change or eliminate any development right authorized thereby. Such conditions shall be incorporated into and made a part of this Agreement, and shall be enforceable against Developer and Land Owner, in the event Developer proceeds with development of the Facility.

5. In the event the Developer or its respective successors, assigns, and/or transferees attempt to proceed, or do proceed, with actions to complete any improvement of the Land, or any portion of it, in any manner other than for the development and operation of the Facility, as shown on the PSLR Overlay Concept Plan, the City shall be authorized to revoke all outstanding building permits and any certificates of occupancy issued for such building and use on the Land. In addition, any material violation of the City's Code of Ordinances by Developer or Land Owner and/or any successor owners or occupants with respect to the Land shall be deemed a breach of this Agreement, as well as a violation of the City's Code of Ordinances. A breach of this Agreement shall constitute a nuisance *per se*, which shall be abated. Developer, the Land Owner, and the City therefore agree that, in the event of a breach of this Agreement by the Developer or Land Owner, the City, in addition to any other relief to which it may be entitled at law or in equity, shall be entitled under this Agreement to relief in the form of specific performance and an order of the court requiring abatement of the nuisance *per se*. The rights in this Paragraph 5 are in addition to the legal and equitable rights that the City has by statute, ordinance, or other law. In the event of a breach of under this Paragraph, the City shall notify Developer and Land Owner of the occurrence of the breach and shall provide the Developer and/or Land Owner, as applicable, with a reasonable period of time to cure any such default and Developer and/or Land Owner, as applicable, shall cure such default during such period; provided, however, that in no event shall the notice period be less than 30 days.
6. By execution of this Agreement, Developer and Land Owner acknowledge that they have acted in consideration of the City approving the proposed use on the Land, and Developer and Land Owner agree to be bound by the provisions of this Agreement, including the recitals and all exhibits attached hereto, which are incorporated by this reference and made a part of this Agreement.
7. Developer and Land Owner acknowledge and agree that they have had the opportunity to have the PSLR Concept Plan and this Agreement, reviewed by legal counsel. Developer and Land Owner have negotiated with City the terms of this Agreement and of the PLSR Overlay Concept Plan, and such documentation represents the product of the joint efforts and mutual agreements of Developer, Land Owner, and City. Developer and Land Owner accept and agree to the final terms, conditions, requirements and obligations of the Agreement and the PLSR Overlay Concept Plan, and Developer and Land Owner shall not be permitted in the future to claim that the effect of the Agreement and PLSR Overlay Concept Plan results in an unreasonable limitation upon uses of all or a portion of the Land, or claim that enforcement of the Agreement and Concept Plan causes an inverse condemnation, other condemnation or taking of all or any portion of the Land. Developer and Land Owner and City agree that this Agreement and its terms, conditions, and requirements are lawful and consistent with the intent and provisions of local ordinances, state and federal law, and the Constitutions of the State of Michigan

and the United States of America. Developer and Land Owner have offered and agreed to proceed with the undertakings and obligations as set forth in this Agreement in order to protect the public health, safety, and welfare and provide material advantages and development options for Developer and Land Owner, all of which undertakings and obligations Developer and Land Owner and City agree are necessary in order to ensure public health, safety, and welfare, to ensure compatibility with adjacent uses of land, to promote use of the Land in a socially, environmentally, and economically desirable manner, and to achieve other reasonable and legitimate objective of City and Developer and Land Owner, as authorized under applicable City ordinances and the Michigan Zoning Enabling Act, MCL 125.3101, *et seq.*, as amended. Furthermore, Developer and Land Owner fully accept and agree to the final terms, conditions, requirements, and obligations of this Agreement and the PLSR Overlay Concept Plan, and Developer and Land Owner shall not be permitted in the future to claim that the effect of this Agreement or the PLSR Overlay Concept Plan results in an unreasonable limitation upon use of all or any portion of the Land, or to claim that enforcement of this Agreement or the PLSR Overlay Concept Plan causes an inverse condemnation or taking of all or any portion of such property. It is further agreed and acknowledged that the terms, conditions, obligations, and requirements of this Agreement and the PLSR Overlay Concept Plan are clearly and substantially related to the burdens to be created by the development and use of the Land under the approved PLSR Concept Plan and this Agreement, and are, without exception, clearly and substantially related to City's legitimate interests in protecting the public health, safety and general welfare. Nothing in this paragraph however limits Developer and Land Owner right to seek enforcement of this Agreement for City's breach of any of its terms

8. This Agreement shall be binding upon and inure to the benefit of the parties to this Agreement and their respective heirs, successors, assigns and transferees. This Agreement shall be recorded with the office of the Oakland County Register of Deeds as to all affected parcels, and the approval of the proposed use shall not become effective until such recording has occurred. Thereafter, any development of the Land shall be in accordance with this Agreement, the PLSR Overlay Concept Plan, and any approved site plans.
9. This Agreement has been duly authorized by all necessary action of the Land Owner, Developer, and the City.
10. No waiver of any breach of this Agreement shall be held to be a waiver of any other or subsequent breach. All remedies afforded in this Agreement shall be taken and construed as cumulative; that is, in addition to every other remedy provided by law.
11. In the event that there is a failure in any material respect by the Developer or Land Owner to perform any obligations required by this Agreement, the City shall serve written notice thereof setting forth such default and shall provide the

Developer and/or Land Owner, as applicable, with a reasonable period of time to cure any such default and Developer and/or Land Owner, as applicable, shall cure such default or take reasonable commercial steps to commence and pursue such a cure during such period; provided, however, in no event, shall the notice period be less than 30 days.

12. This Agreement shall be governed by the laws of the State of Michigan, both as to interpretation and performance. Any and all suits for any and every breach of this Agreement may be instituted and maintained in any court of competent jurisdiction in the County of Oakland, State of Michigan.
13. This Agreement is intended as the complete integration of all understandings among the parties related to the subject matter herein. No prior contemporaneous addition, deletion, or other amendment shall have any force or effect whatsoever, unless embodied herein in writing. Except for additional conditions imposed as part of the development approval process, as described in Section 4 above, this Agreement may be amended only as provided in the PLSR Overlay District ordinance, Article 23B *et seq.* of the City's Zoning Ordinance, including a writing signed by all parties to the Agreement.
14. The Zoning Board of Appeals shall have no jurisdiction over the Land or the application of this Agreement.
15. It is understood by Developer and Land Owner that construction of some of the improvements included in the Concept Plan may require the approval of other governmental agencies, and that failure to obtain such approvals does not invalidate this Agreement or the PLSR Overlay Concept Plan.
16. None of the terms or provisions of this Agreement shall be deemed to create a partnership or joint venture between the Developer and Land Owner and the City.
17. The parties intend that this Agreement shall create no third-party beneficiary interest.
18. Where there is a question with regard to applicable regulations for a particular aspect of the development of the Facility, or with regard to clarification, interpretation, or definition of terms or regulations, and there are no apparent express provisions of this Agreement that apply, the City, in the reasonable exercise of its discretion, shall determine the regulations of the City's Zoning Ordinance, as that Ordinance may have been amended, or other City Ordinances that shall be applicable, provided that such determination is not inconsistent with the nature and intent of the Concept Plan and the this Agreement. In the event of a conflict or inconsistency between two or more provisions of the Agreement and Concept Plan, or between the Agreement and Concept Plan and applicable City ordinances, the more restrictive provision, as determined in the

reasonable discretion of the City, shall apply.

19. This Agreement may be signed in counterparts.

THE UNDERSIGNED have executed this Agreement effective as of the day and year first written above.

PROVIDENCE PARK SENIOR
LIVING, LLC
a Michigan limited liability company

By: 
WARREN ROSE

Its: Authorized Manager

STATE OF MICHIGAN)
) ss.
COUNTY OF OAKLAND)

On this, 22 day of July, 2014, before me appeared Warren Rose, Authorized Manager of Providence Park Senior Living, LLC, a Michigan limited liability company, who states that he has signed this document of his own free will, duly authorized on behalf of Providence Park Senior Living, LLC.



Notary Public

DAWN E. SCHULTZ
NOTARY PUBLIC, STATE OF MI
COUNTY OF OAKLAND
MY COMMISSION EXPIRES Jun 26, 2016
ACTING IN COUNTY OF OAKLAND

[SIGNATURES CONTINUE ON NEXT PAGE]

Marilyn S. Troutman
Printed Name: MARILYN S. TROUTMAN

CITY OF NOVI
Robert J. Gatt
By: Robert J. Gatt, Mayor

Deborah S. Aubry
Printed Name: Deborah S. Aubry

Marilyn S. Troutman
Printed Name: MARILYN S. TROUTMAN

Maryanne Cornelius
By: Maryanne Cornelius, Clerk

Deborah S. Aubry
Printed Name: Deborah S. Aubry

STATE OF MICHIGAN)
) ss.
COUNTY OF OAKLAND)

On this 8th day of JUNE, 2014, before me appeared Robert J. Gatt, Mayor, and Maryanne Cornelius, Clerk, who each stated that they have signed this document of their own free will on behalf of the City of Novi in their respective official capacities.

MARILYN S. TROUTMAN
NOTARY PUBLIC, STATE OF MI
COUNTY OF WAYNE
MY COMMISSION EXPIRES ON 13, 2017
ACTING IN COUNTY OF OAKLAND

Marilyn S. Troutman
Notary Public

[SIGNATURES CONTINUE ON NEXT PAGE]

**PROVIDENCE HOSPITAL AND
MEDICAL CENTERS, INC.**
a Michigan not-for-profit corporation

By: 

Name: Peter Karadjoff

Its: President, Providence Park

STATE OF MICHIGAN)
) ss.
COUNTY OF OAKLAND)

On this, 16 day of January, 2014⁵, before me appeared Peter Karadjoff
President of Providence Hospital and Medical Centers, Inc., a Michigan not-for-profit corporation, who states that he has signed this document of his own free will, duly authorized on behalf of Providence Hospital and Medical Centers, Inc.



Notary Public

DAWN E. SCHULTZ
NOTARY PUBLIC, STATE OF MI
COUNTY OF OAKLAND
MY COMMISSION EXPIRES Jun 26, 2016
ACTING IN COUNTY OF OAKLAND

When recorded return to:

Maryanne Cornelius, Clerk
City of Novi
45175 West Ten Mile Road
Novi, MI 48375-3024

MB

Drafted by:

Nathan Anderson, Agent
Rose Senior Living, LLC
38525 Woodward Avenue
Bloomfield Hills, MI 48304

Exhibit A – Legal Description of Land

Part of the Southeast $\frac{1}{4}$ of Section 17, Town 1 North, Range 8 East, City of Novi, Oakland County, Michigan, described as: Beginning at a point distant South 87 degrees 17 minutes 07 seconds West 60.00 feet along the East-West $\frac{1}{4}$ line to the west right of way line of Beck Road (variable right of way) and South 01 degrees 21 minutes 47 seconds East 1,233.19 feet along said right of way line from the East $\frac{1}{4}$ corner of said Section 17 and the POINT OF BEGINNING; thence continuing along said right of way line South 01 degrees 21 minutes 47 seconds East 191.62 feet; thence South 88°30'39" West 134.26 feet; thence North 85°13'39" West 100.27 feet; thence along a curve to the left 148.13 feet; said curve having a radius of 168.00 feet, a central angle of 50°31'12", and a chord bearing South 61°40'10" West 143.38 feet; thence South 36°24'34" West 109.30 feet; thence along a curve to the right 215.91 feet, said curve having a radius of 530.00 feet, a central angle of 23°20'28", and a chord bearing South 48°04'48" West 214.42 feet; thence South 59°45'02" West 71.84 feet; thence along a curve to the left 95.14 feet, said curve having a radius of 320.00 feet, a central angle of 17°02'08", and a chord bearing South 51°13'58" West 94.79 feet; thence South 42°42'54" West 69.93 feet; thence South 01°54'30" E 808.47 feet thence South 87°21'00" West 326.50 feet; thence North 01°54'30" West 667.00 feet; thence South 87 degrees 20 minutes 58 seconds West 27.61 feet; thence North 40 degrees 32 minutes 01 seconds West 706.88 feet; thence North 02 degrees 44 minutes 13 seconds West 139.31 feet; thence North 87 degrees 15 minutes 47 seconds East 832.17 feet; thence along a curve to the right 47.41 feet, said curve having a radius of 530.00 feet, a central angle of 05 degrees 07 minutes 29 seconds and a chord bearing North 10 degrees 01 minutes 23 seconds West 47.39 feet; thence North 87 degrees 53 minutes 16 seconds East 756.21 feet to the POINT OF BEGINNING. Said description contains 902,305 square feet, or 20.71 acres, more or less.

Tax Parcel No. 22-17-400-040 (part)

MPS

Exhibit A -- Legal Description of Land

SKETCH OF DESCRIPTION

FILE - 15-MR-2014 06.39

PEN TEL - i:\msa\p\kittling\sketch.dwg

QUEIE - \np\pa\Survey_Logical_Cad28_TBL - i:\msv\N\N\Ar\Ar\color2.dwg

DESIGN FILE - i:\20130620\130648\FY13648.dwg_P02.dgn

USER NAME - dhsbert

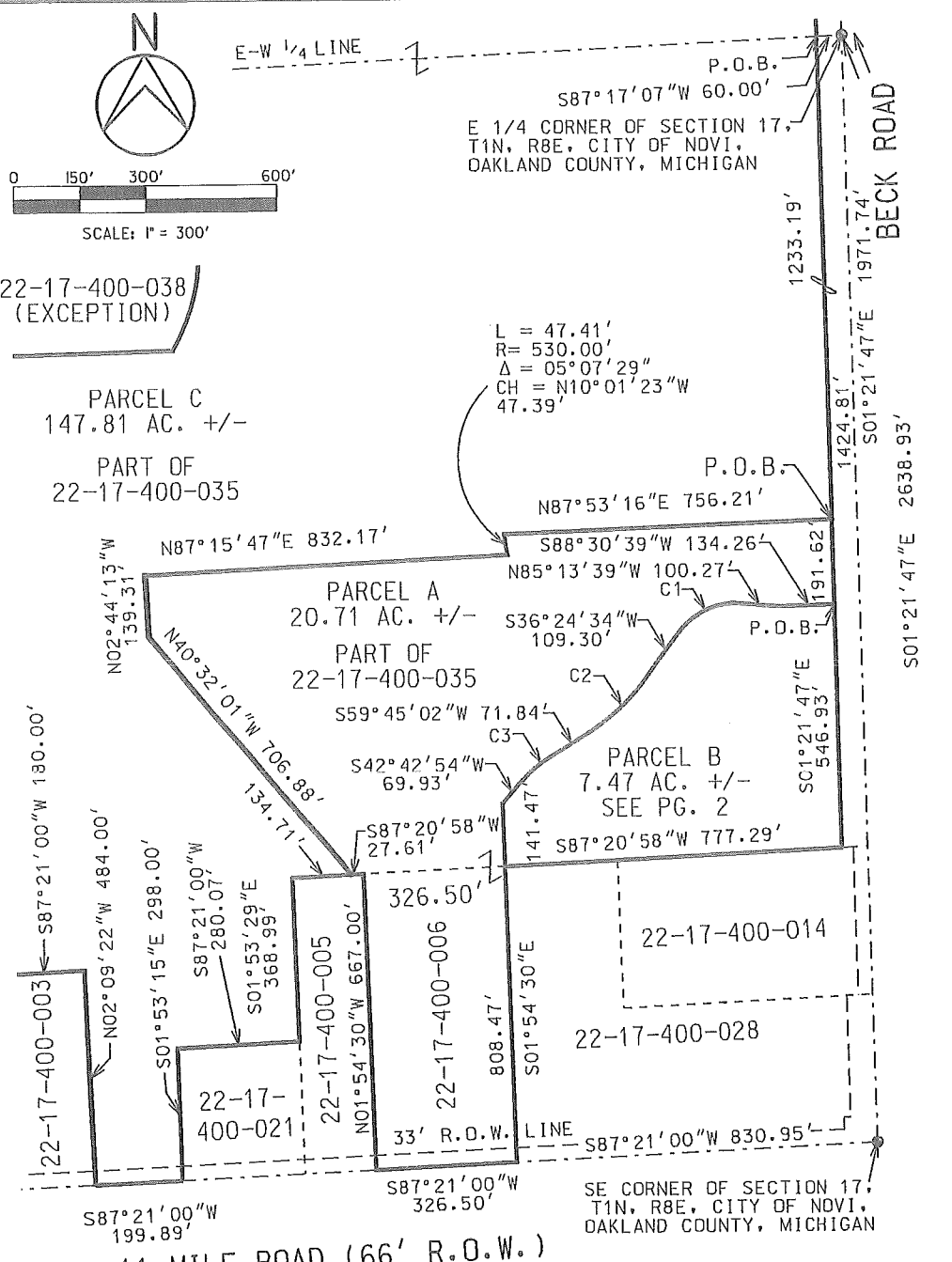

REV. 04-15-14
REV. 04-11-14

JOB NO. 20130648	HUBBELL, ROTH & CLARK, INC. CONSULTING ENGINEERS 555 HULET DRIVE BLOOMFIELD HILLS, MICH.	P.O. BOX 824 48303-0824
DATE 04-09-14		SHEET NO. 2 OF 5

MRT

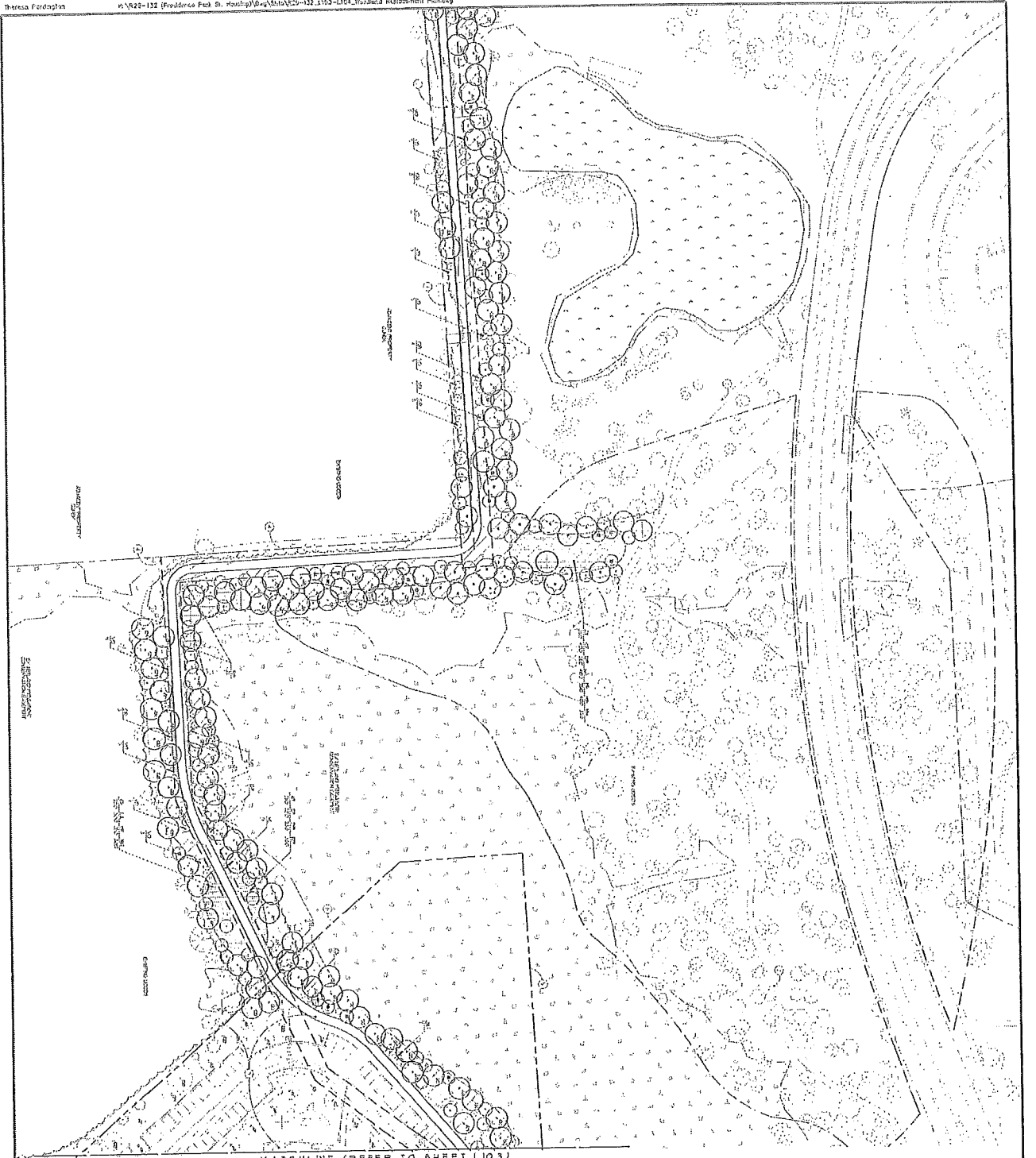

Ordinance - Cashierland Notes:
 Proposed Development:
 1. The project shall be subject to the provisions of the current Ordinance and any amendments thereto.
 2. The project shall be subject to the provisions of the current Ordinance and any amendments thereto.
 3. The project shall be subject to the provisions of the current Ordinance and any amendments thereto.
 4. The project shall be subject to the provisions of the current Ordinance and any amendments thereto.

PROJECT NO.	22-132
PROJECT NAME	ROSE SENIOR LIVING AT PROVIDENCE PARK
DATE	04/24/14
DRAWN BY	THeresa Fordgripin
CHECKED BY	[blank]
APPROVED BY	[blank]

- 1. The project shall be subject to the provisions of the current Ordinance and any amendments thereto.
- 2. The project shall be subject to the provisions of the current Ordinance and any amendments thereto.
- 3. The project shall be subject to the provisions of the current Ordinance and any amendments thereto.
- 4. The project shall be subject to the provisions of the current Ordinance and any amendments thereto.

- Notes:**
1. Refer to the attached site plan for details.
 2. All construction shall be in accordance with the attached specifications.
 3. All construction shall be in accordance with the attached specifications.
 4. All construction shall be in accordance with the attached specifications.
 5. All construction shall be in accordance with the attached specifications.

Graphic Legend:

(Symbol)	ROSE SENIOR LIVING AT PROVIDENCE PARK
(Symbol)	PROVIDENCE PARK
(Symbol)	LANDSCAPING
(Symbol)	ROADWAY
(Symbol)	UTILITY
(Symbol)	EXISTING

SCALE: 1" = 50'

GRISSIM METZ ASSOCIATES ANDRIESE
 305 West 43rd Street
 Suite 101
 Kansas City, MO 64112
 (816) 384-4400

HFC
 1000 N. Main Street
 Suite 100
 Kansas City, MO 64105
 (816) 734-1100

ROSE SENIOR LIVING AT PROVIDENCE PARK
 NORTHWEST WOODLAND RENOVATION PLAN
 SHEET L104
 DATE: 04/24/14
 DRAWN BY: Theresa Fordgripin
 CHECKED BY: [blank]
 APPROVED BY: [blank]

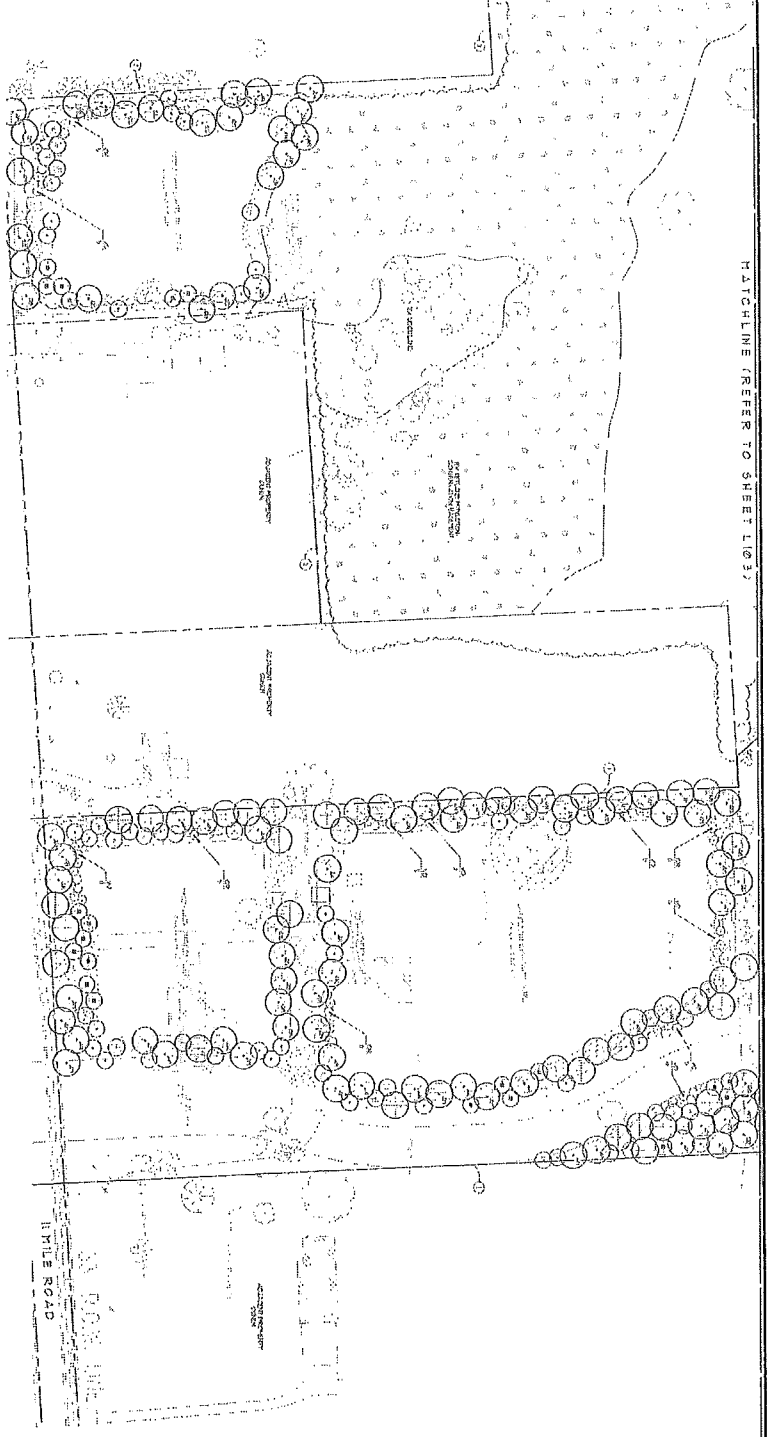

HATCHLINE (REFER TO SHEET L103)

HITLE ROAD

Ordinance Classification Notes:

1. Ordinance 15.02.010 (Ordinance 15.02.010) requires that all new construction be designed to meet the minimum standards for fire safety, including fire alarm, fire extinguishers, fire escape, and fire hydrant access. The minimum standards for fire safety are as follows:
 - a. Fire alarm: All new construction must be equipped with a fire alarm system that meets the minimum standards for fire safety.
 - b. Fire extinguishers: All new construction must be equipped with fire extinguishers that meet the minimum standards for fire safety.
 - c. Fire escape: All new construction must be equipped with fire escapes that meet the minimum standards for fire safety.
 - d. Fire hydrant access: All new construction must be equipped with fire hydrant access that meets the minimum standards for fire safety.
2. Ordinance 15.02.020 (Ordinance 15.02.020) requires that all new construction be designed to meet the minimum standards for fire safety, including fire alarm, fire extinguishers, fire escape, and fire hydrant access. The minimum standards for fire safety are as follows:
 - a. Fire alarm: All new construction must be equipped with a fire alarm system that meets the minimum standards for fire safety.
 - b. Fire extinguishers: All new construction must be equipped with fire extinguishers that meet the minimum standards for fire safety.
 - c. Fire escape: All new construction must be equipped with fire escapes that meet the minimum standards for fire safety.
 - d. Fire hydrant access: All new construction must be equipped with fire hydrant access that meets the minimum standards for fire safety.

Notes:

1. The location of the proposed site is shown on the site plan. The site is located at the intersection of Hitle Road and Little Road.
2. The proposed site is shown on the site plan. The site is located at the intersection of Hitle Road and Little Road.
3. The proposed site is shown on the site plan. The site is located at the intersection of Hitle Road and Little Road.
4. The proposed site is shown on the site plan. The site is located at the intersection of Hitle Road and Little Road.
5. The proposed site is shown on the site plan. The site is located at the intersection of Hitle Road and Little Road.
6. The proposed site is shown on the site plan. The site is located at the intersection of Hitle Road and Little Road.
7. The proposed site is shown on the site plan. The site is located at the intersection of Hitle Road and Little Road.
8. The proposed site is shown on the site plan. The site is located at the intersection of Hitle Road and Little Road.
9. The proposed site is shown on the site plan. The site is located at the intersection of Hitle Road and Little Road.
10. The proposed site is shown on the site plan. The site is located at the intersection of Hitle Road and Little Road.
11. The proposed site is shown on the site plan. The site is located at the intersection of Hitle Road and Little Road.
12. The proposed site is shown on the site plan. The site is located at the intersection of Hitle Road and Little Road.
13. The proposed site is shown on the site plan. The site is located at the intersection of Hitle Road and Little Road.
14. The proposed site is shown on the site plan. The site is located at the intersection of Hitle Road and Little Road.
15. The proposed site is shown on the site plan. The site is located at the intersection of Hitle Road and Little Road.
16. The proposed site is shown on the site plan. The site is located at the intersection of Hitle Road and Little Road.
17. The proposed site is shown on the site plan. The site is located at the intersection of Hitle Road and Little Road.
18. The proposed site is shown on the site plan. The site is located at the intersection of Hitle Road and Little Road.
19. The proposed site is shown on the site plan. The site is located at the intersection of Hitle Road and Little Road.
20. The proposed site is shown on the site plan. The site is located at the intersection of Hitle Road and Little Road.

Graphic Legend:

- 1. Proposed site boundary
- 2. Existing site boundary
- 3. Proposed site boundary
- 4. Existing site boundary
- 5. Proposed site boundary
- 6. Existing site boundary
- 7. Proposed site boundary
- 8. Existing site boundary
- 9. Proposed site boundary
- 10. Existing site boundary
- 11. Proposed site boundary
- 12. Existing site boundary
- 13. Proposed site boundary
- 14. Existing site boundary
- 15. Proposed site boundary
- 16. Existing site boundary
- 17. Proposed site boundary
- 18. Existing site boundary
- 19. Proposed site boundary
- 20. Existing site boundary

Note Key:

1. Proposed site boundary
2. Existing site boundary
3. Proposed site boundary
4. Existing site boundary
5. Proposed site boundary
6. Existing site boundary
7. Proposed site boundary
8. Existing site boundary
9. Proposed site boundary
10. Existing site boundary
11. Proposed site boundary
12. Existing site boundary
13. Proposed site boundary
14. Existing site boundary
15. Proposed site boundary
16. Existing site boundary
17. Proposed site boundary
18. Existing site boundary
19. Proposed site boundary
20. Existing site boundary

Symbol	Description
①	Proposed site boundary
②	Existing site boundary
③	Proposed site boundary
④	Existing site boundary
⑤	Proposed site boundary
⑥	Existing site boundary
⑦	Proposed site boundary
⑧	Existing site boundary
⑨	Proposed site boundary
⑩	Existing site boundary
⑪	Proposed site boundary
⑫	Existing site boundary
⑬	Proposed site boundary
⑭	Existing site boundary
⑮	Proposed site boundary
⑯	Existing site boundary
⑰	Proposed site boundary
⑱	Existing site boundary
⑲	Proposed site boundary
⑳	Existing site boundary

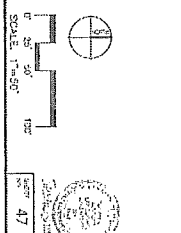

ROSE SENIOR LIVING
at Providence Park
12-88857-010

GRISSIM METZ ASSOCIATES ANDRUSSE
300 5th Ave. S.W.
Birmingham, AL 35203
Tel: 888-857-0100

HRC
Hatchline Refer to Sheet L103

NO.	DESCRIPTION	DATE	BY
1	Initial Design	4/24/2014	J. Smith
2	Revised Design	4/24/2014	J. Smith
3	Final Design	4/24/2014	J. Smith
4	Construction Documents	4/24/2014	J. Smith
5	As-Built Documents	4/24/2014	J. Smith

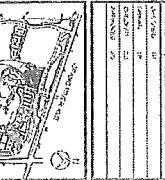

ROSE SENIOR LIVING AT PROVIDENCE PARK
CITY OF BIRMINGHAM

ROSE SENIOR LIVING AT PROVIDENCE PARK
CITY OF BIRMINGHAM

SOUTH/CENTRAL WOODLAND REDEVELOPMENT PLAN
L103

MCA

Exhibit D

Woodland Conservation Easement Areas

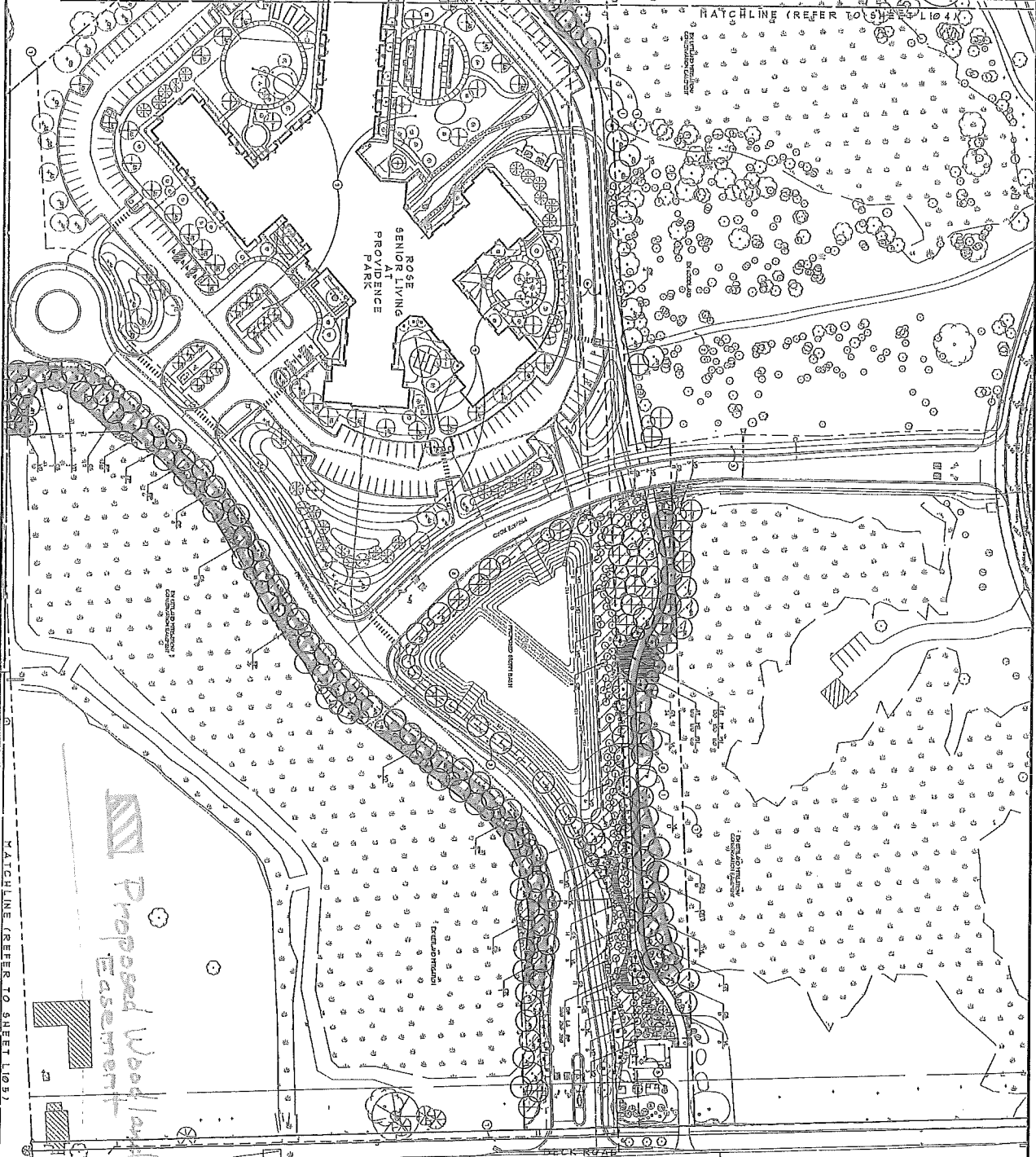

Ordinance Consideration Notes:

Residential Use Intensity:

1. The maximum number of units per acre is limited to the following:

Use Intensity	Maximum Units per Acre
Single-Family Detached	10
Single-Family Attached	20
Multi-Family (Low Density)	30
Multi-Family (Medium Density)	40
Multi-Family (High Density)	50
Multi-Family (Very High Density)	60
Multi-Family (Ultra High Density)	70
Multi-Family (Super High Density)	80
Multi-Family (Extreme High Density)	90

2. The maximum number of units per acre is limited to the following:

Use Intensity	Maximum Units per Acre
Single-Family Detached	10
Single-Family Attached	20
Multi-Family (Low Density)	30
Multi-Family (Medium Density)	40
Multi-Family (High Density)	50
Multi-Family (Very High Density)	60
Multi-Family (Ultra High Density)	70
Multi-Family (Super High Density)	80
Multi-Family (Extreme High Density)	90

Graphic Legend:

- 1. Name of street and road center
- 2. Right-of-way boundary
- 3. Property boundary
- 4. Proposed building footprint
- 5. Existing building footprint
- 6. Existing parking lot
- 7. Proposed parking lot
- 8. Existing driveway
- 9. Proposed driveway
- 10. Existing sidewalk
- 11. Proposed sidewalk
- 12. Existing utility
- 13. Proposed utility
- 14. Existing fence
- 15. Proposed fence
- 16. Existing landscape
- 17. Proposed landscape
- 18. Existing tree
- 19. Proposed tree
- 20. Existing tree to be removed
- 21. Proposed tree to be removed
- 22. Existing tree to be preserved
- 23. Proposed tree to be preserved
- 24. Existing tree to be planted
- 25. Proposed tree to be planted
- 26. Existing tree to be removed and replaced
- 27. Proposed tree to be removed and replaced
- 28. Existing tree to be preserved and replaced
- 29. Proposed tree to be preserved and replaced
- 30. Existing tree to be planted and replaced
- 31. Proposed tree to be planted and replaced

Scale: 1" = 50'

North Arrow: [Symbol]

Graphic Legend:

- 1. Name of street and road center
- 2. Right-of-way boundary
- 3. Property boundary
- 4. Proposed building footprint
- 5. Existing building footprint
- 6. Existing parking lot
- 7. Proposed parking lot
- 8. Existing driveway
- 9. Proposed driveway
- 10. Existing sidewalk
- 11. Proposed sidewalk
- 12. Existing utility
- 13. Proposed utility
- 14. Existing fence
- 15. Proposed fence
- 16. Existing landscape
- 17. Proposed landscape
- 18. Existing tree
- 19. Proposed tree
- 20. Existing tree to be removed
- 21. Proposed tree to be removed
- 22. Existing tree to be preserved
- 23. Proposed tree to be preserved
- 24. Existing tree to be planted
- 25. Proposed tree to be planted
- 26. Existing tree to be removed and replaced
- 27. Proposed tree to be removed and replaced
- 28. Existing tree to be preserved and replaced
- 29. Proposed tree to be preserved and replaced
- 30. Existing tree to be planted and replaced
- 31. Proposed tree to be planted and replaced

<p>ROSE SENIOR LIVING at Providence Park</p>	<p>GRISSIM METZ ASSOCIATES ANDRIESE 300 East 104th Street Indianapolis, IN 46240 Tel: 317.439.7210</p>	<p>HRC HERRILL, SMITH & COLLIER, INC. Architects/Engineers</p> <p>P.A. 021212 1000 North College Avenue Indianapolis, IN 46203 Tel: 317.439.7210</p>	<p>ROSE SENIOR LIVING AT PROVIDENCE PARK</p> <p>PROJECT LOCATION</p>	<p>CENTRAL WOODLAND REPLACEMENT PLAN</p> <p>SCALE: AS SHOWN</p> <p>SHEET: L103</p>
---	---	---	---	---

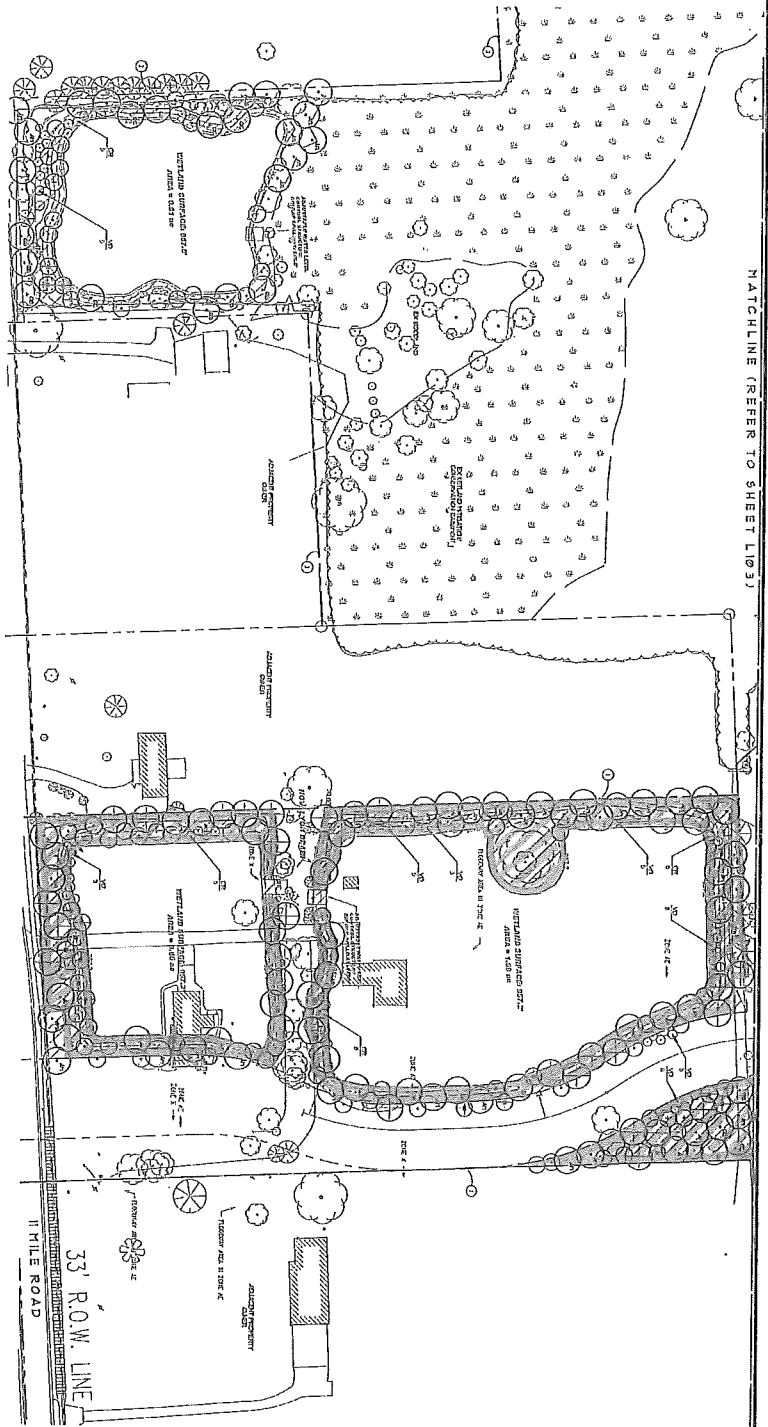

Proposed Woodland Easement

33' ROW LINE
11 MILE ROAD

MATCHLINE (REFER TO SHEET L103)

Ordinance Consideration Notes:

1. **Water/Water Treatment**
 - 1.1. Applicant is providing a Subsurface Infiltration System to treat and store stormwater runoff. The system will be installed in a wooded area of the site and will be designed to meet the requirements of the City of Providence Park Ordinance 11.02.010.
 - 1.2. The system will be installed in a wooded area of the site and will be designed to meet the requirements of the City of Providence Park Ordinance 11.02.010.
2. **Soil Stabilization**
 - 2.1. The applicant is providing a soil stabilization plan for the site. The plan includes the installation of a vegetative buffer strip along the 11 Mile Road right-of-way line. The buffer strip will be planted with native species and will be maintained for a period of five years.
 - 2.2. The applicant is providing a soil stabilization plan for the site. The plan includes the installation of a vegetative buffer strip along the 11 Mile Road right-of-way line. The buffer strip will be planted with native species and will be maintained for a period of five years.

Item	Quantity	Unit	Material	Notes
1.00	1	Lot	11 Mile Road	Right-of-way line
2.00	1	Lot	11 Mile Road	Right-of-way line
3.00	1	Lot	11 Mile Road	Right-of-way line
4.00	1	Lot	11 Mile Road	Right-of-way line
5.00	1	Lot	11 Mile Road	Right-of-way line
6.00	1	Lot	11 Mile Road	Right-of-way line
7.00	1	Lot	11 Mile Road	Right-of-way line
8.00	1	Lot	11 Mile Road	Right-of-way line
9.00	1	Lot	11 Mile Road	Right-of-way line
10.00	1	Lot	11 Mile Road	Right-of-way line

Graphic Legend:

- 1. **EXISTING**
- 2. **PROPOSED**
- 3. **PROPOSED WITH REVISIONS**
- 4. **PROPOSED WITH REVISIONS - ALL CONDITIONS**
- 5. **PROPOSED WITH REVISIONS - ALL CONDITIONS**
- 6. **PROPOSED WITH REVISIONS - ALL CONDITIONS**
- 7. **PROPOSED WITH REVISIONS - ALL CONDITIONS**
- 8. **PROPOSED WITH REVISIONS - ALL CONDITIONS**
- 9. **PROPOSED WITH REVISIONS - ALL CONDITIONS**
- 10. **PROPOSED WITH REVISIONS - ALL CONDITIONS**
- 11. **PROPOSED WITH REVISIONS - ALL CONDITIONS**
- 12. **PROPOSED WITH REVISIONS - ALL CONDITIONS**
- 13. **PROPOSED WITH REVISIONS - ALL CONDITIONS**
- 14. **PROPOSED WITH REVISIONS - ALL CONDITIONS**
- 15. **PROPOSED WITH REVISIONS - ALL CONDITIONS**
- 16. **PROPOSED WITH REVISIONS - ALL CONDITIONS**
- 17. **PROPOSED WITH REVISIONS - ALL CONDITIONS**
- 18. **PROPOSED WITH REVISIONS - ALL CONDITIONS**
- 19. **PROPOSED WITH REVISIONS - ALL CONDITIONS**
- 20. **PROPOSED WITH REVISIONS - ALL CONDITIONS**

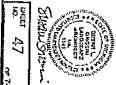
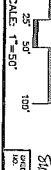

ROOSE SENIOR LIVING AT PROVIDENCE PARK
CITY OF OREGON

SOUP/GENERAL RENOVATION PLAN

SCALE: AS SHOWN
DATE: FEBRUARY 2014
SHEET: L105

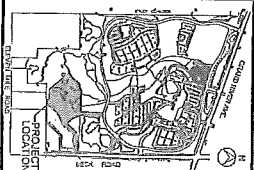

NO.	DESCRIPTION	DATE	BY	CHKD.
1	ISSUED FOR PERMIT	02/11/14	SMITH	SMITH
2	ISSUED FOR PERMIT	02/11/14	SMITH	SMITH
3	ISSUED FOR PERMIT	02/11/14	SMITH	SMITH
4	ISSUED FOR PERMIT	02/11/14	SMITH	SMITH
5	ISSUED FOR PERMIT	02/11/14	SMITH	SMITH
6	ISSUED FOR PERMIT	02/11/14	SMITH	SMITH
7	ISSUED FOR PERMIT	02/11/14	SMITH	SMITH
8	ISSUED FOR PERMIT	02/11/14	SMITH	SMITH
9	ISSUED FOR PERMIT	02/11/14	SMITH	SMITH
10	ISSUED FOR PERMIT	02/11/14	SMITH	SMITH

HRC
Housing Resource Center
11111 N. 11th St.
Portland, OR 97228
503.281.1111
www.hrcportland.org

GRISSIM METZ ASSOCIATES ANDRIESE
300 East Oak Street
Portland, OR 97214
503.281.1111

ROOSE SENIOR LIVING at Providence Park

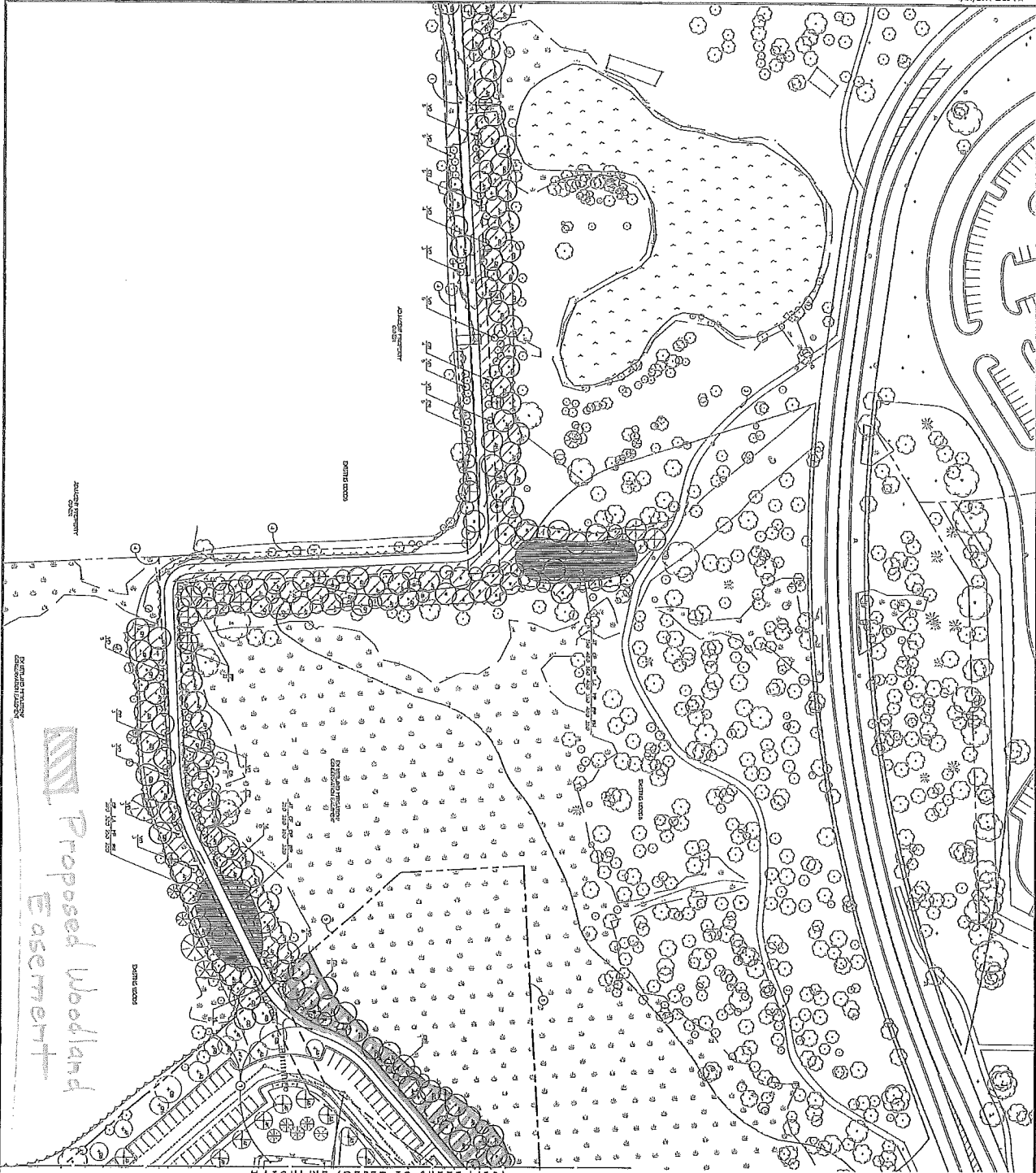

Ordinance Consideration Notes:
 1. Applicant is proposing a 3-story residential replacement for a 2-story existing structure. The proposed structure is within the same lot as the existing structure. The proposed structure is within the same lot as the existing structure.
 2. The proposed structure is within the same lot as the existing structure. The proposed structure is within the same lot as the existing structure.
 3. The proposed structure is within the same lot as the existing structure. The proposed structure is within the same lot as the existing structure.

Notes:
 1. The plan of structural replacement is based on the structural analysis of the existing structure. The structural analysis is based on the structural analysis of the existing structure.
 2. The plan of structural replacement is based on the structural analysis of the existing structure. The structural analysis is based on the structural analysis of the existing structure.
 3. The plan of structural replacement is based on the structural analysis of the existing structure. The structural analysis is based on the structural analysis of the existing structure.

Graphic Legend:
 (Symbol) Existing Structure
 (Symbol) Proposed Structure
 (Symbol) Proposed Woodland Easement
 (Symbol) Proposed Replacement

North Arrow:
 (Symbol) North Arrow

Scale:
 1" = 50'

Sheet Information:
 SHEET NO. 46
 TOTAL SHEETS 46

GRISSIM METZ ASSOCIATES ANDRIESE
 20101 44th Street
 Redmond, WA 98073
 Tel: (206) 752-7310

HRC
 HERRINGTON, ROBINSON & COMPANY, INC.
 1320 FIRST STREET
 BOSTON, MA 02114
 Tel: (617) 552-1234

ROSE SENIOR LIVING
 AT PROVIDENCE PARK
 CITY OF BIRMINGHAM

DRAWN BY: [Name] PROJECT NO: [Number]
 CHECKED BY: [Name] SHEET NO: 46 OF 46