



**CITY OF NOVI CITY COUNCIL  
JULY 10, 2023**

**SUBJECT:** Approval to purchase rapid deployment barricades for the Novi Police Department from Meridian Rapid Defense Group, sole source provider and through an existing GSA contract, for a total of \$155,646.18.

**SUBMITTING DEPARTMENT:** Public Safety – Police Department

<b>EXPENDITURE REQUIRED</b>	<b>\$155,646.18</b>
<b>AMOUNT BUDGETED</b>	<b>\$157,700</b>
<b>APPROPRIATION REQUIRED</b>	<b>N/A</b>
<b>LINE ITEM NUMBER</b>	<b>101-301.00-982.089</b>

**BACKGROUND INFORMATION:**

Approved in the 2023-24 Police Department budget is the purchase of rapid deployment barricades. The City of Novi has been a host to many major events, including the Michigan State Fair, Susan G. Komen Walk for a Cure, Motor City Comic Convention, 5K and 10K races, Island Lake Triathlon, Festival of Chariots, Memorial Day, and High School homecoming parades. Past practices for road closures have been to utilize Department of Public Works (DPW) provided Type III and single-stage barricades for primary and secondary road closures. The Type III and single-stage barricades provide an effective means for road closure to most drivers who are compliant with the law.

Unfortunately, during our city-held events, we have had several occurrences of vehicles disobeying the closures and traveling on the roadways /parking areas. This raises potential risks to participants and spectators at events. There also has been a myriad of worldwide incidents where nefarious individuals, terrorists, and home-grown extremists, that have caused death, casualties, and destruction during events. Both intentional and unintentional vehicle-borne attacks are possible and should be planned for at all major events.

This request is to procure sixteen Archer 1200 portable barricades with an Archer 8-barrier drop deck trailer. These barricades will enhance the Department's security capabilities and will be utilized during events held in the City of Novi for the safety and protection of citizens.

**RECOMMENDED ACTION:** Approval to purchase rapid deployment barricades for the Novi Police Department from Meridian Rapid Defense Group, sole source provider and through an existing GSA contract, for a total of \$155,646.18.

# Quote

177 E. Colorado Blvd, Suite 200  
 Pasadena, CA 91105  
 +1 8186419802  
 Awalter@meridian-barrier.com



**Schedule 84**  
 Contract 47QSWA19D001F

**ADDRESS**  
 Sgt Brian Woloski  
 Novi Police Department  
 45125 Ten Mile Road  
 Novi, MI 48375

**SHIP TO**  
 Sgt Brian Woloski  
 Novi Police Department  
 45125 Ten Mile Road  
 Novi, MI 48375

QUOTE #	DATE	EXPIRATION DATE
S-20230605MI-1	06/02/2023	09/02/2023

PRODUCT	DESCRIPTION	QTY	RATE	AMOUNT
<b>8 Barrier Trailer Kit - GSA</b>	8 Barrier Trailer Kit	1	84,664.34	84,664.34
<b>Archer 1200 Barrier - GSA</b>	Archer 1200 Anti-Vehicle Barrier	8	6,513.75	
<b>Archer Hauler - GSA</b>	Archer Hauler™	1	1,925.18	
<b>Archer Field Tow Bar - GSA</b>	Archer Field Tow Bar	2	574.18	
<b>Arrestor Cable (4ft) - GSA</b>	Arrestor Cable™ (4ft)	7	574.18	
<b>Arrestor Cable (10ft) - GSA</b>	Arrestor Cable™ (10ft)	2	670.68	
<b>Archer 8-Barrier Drop Deck Trailer - GSA</b>	Archer 8-Barrier Drop Deck Trailer	1	24,120.18	
<b>Archer 1200 Barrier - GSA</b>	Archer 1200 Anti-Vehicle Barrier	8	6,513.75	52,110.00T
<b>Archer Hauler - GSA</b>	Archer Hauler™	1	1,925.18	1,925.18T
<b>Archer Field Tow Bar - GSA</b>	Archer Field Tow Bar	2	574.18	1,148.36T
<b>Arrestor Cable (4ft) - GSA</b>	Arrestor Cable™ (4ft)	7	574.18	4,019.26T
<b>Arrestor Cable (10ft) - GSA</b>	Arrestor Cable™ (10ft)	2	670.68	1,341.36T
<b>In-Field Installation &amp; Certified Training-GSA</b>	In-Field Installation & Certified Training-GSA	1	1,442.68	1,442.68T

**PAYMENT TERMS:**  
 Due to high demand levels, your delivery date will be guaranteed with your 50% deposit so that your protection starts when you need it.

SUBTOTAL	146,651.18
TAX	0.00
SHIPPING	8,995.00
<b>TOTAL</b>	<b>USD 155,646.18</b>



# Archer® 1200 Vehicle Barrier

An unanchored “drop-and-stop” barrier for rapid deployment on roadways and hard surfaces.

Best-in-class for Hostile Vehicle Mitigation (HVM), MERIDIAN®'s Archer® 1200 Vehicle Barriers fill a specific need that is simply unmatched by anything currently on the market. Strength and flexibility make them a vital component of your overall security plan. MERIDIAN®'s ultimate rapidly deployable Archer® 1200 Barrier can augment fixed-in-place HVM (Hostile Vehicle Mitigation) barriers or be utilized as a primary security system for entry points, roadways and perimeters.

## PRODUCT FEATURES

### RAPID DEPLOYMENT, MODULAR DESIGN

Archer® 1200 Vehicle Barriers provide drop and stop convenience with no heavy equipment required.

- » Allows for one-person deployment of an 8 barrier trailer kit in under 10 minutes.
- » Permits pedestrian and emergency vehicle access without moving a barrier.
- » Archer Hauler allows for easy movement of barriers by adults of any stature.
- » No maintenance, electricity, hydraulics or batteries required.
- » Full ballistic protection for any armor piercing 50 caliber rounds

### REUSABLE

Unlike fixed bollards, our barriers are non-lethal to the driver and minimize shrapnel spray. They are 100% reusable after impact and have a lifetime warranty.

### CERTIFICATIONS



### FEATURES & SPECIFICATIONS

1. Archer® 1200s can be connected into sets of two or more barriers.
2. Heavy-duty back plate digs in to force barrier into the vehicle.
3. Barriers feature ballistic-rated front plate and back gusset.
4. Ramped front plate levers into vehicle undercarriage.

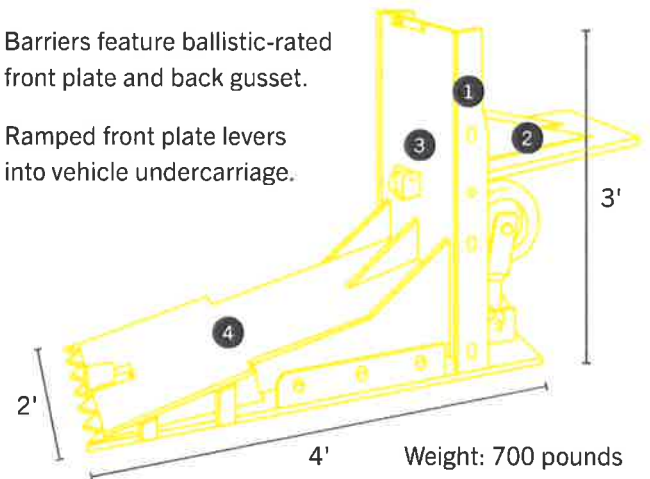

betterbarriers.com | (323) 282-7827

## ARCHER DIRECTIONAL WAYFINDING SIGN



These are collapsible frames which when in the raised position work to communicate with passing people and vehicles. The frames are available in sets of 4 or 8 and 2 with standard signage. They come available in a pack for easy transport. When Archer Barriers are to be moved, the frame is to be lowered so it rests on the back kick plate for easy storage. Keeping the frame on the barriers will help with the speed of deployment during setup. The frames can be colored to match the barriers so that they complete the correct safety look and feel for the community.

### FEATURES

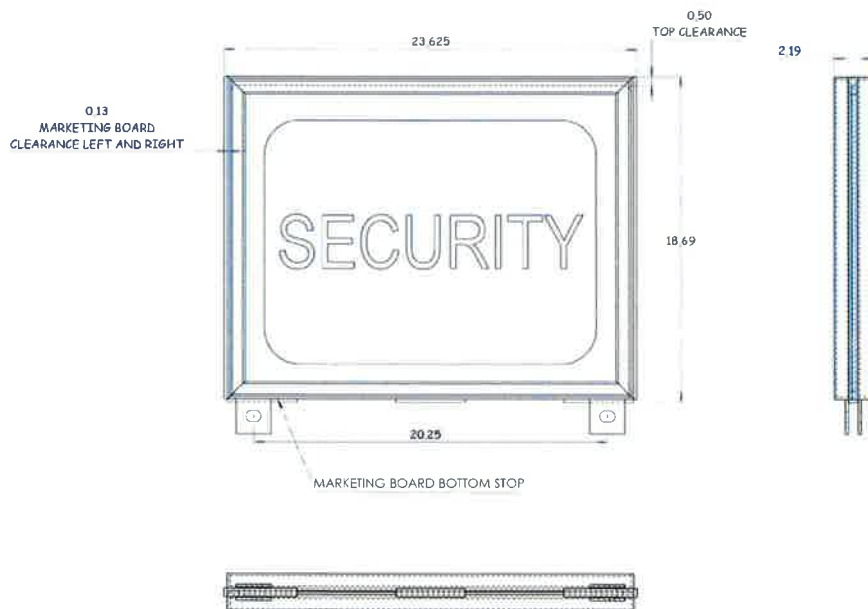

Our Safety Department has put together a series of signs that will ensure that directing traffic and people is made easy. The signs are displayed between 3 and 4 ft. ensuring visual compliance to pedestrians and vehicles. All signs are consistent with standard safety colors and layout so there is no confusion reading them when the barriers or beam gates are deployed.

The Archer Directional Signage frames are bolted on top of the Archer 1200 Barriers. When set in the upright position they can give directions to people and vehicles and can easily go into the down position for transportation. The signs come in two boxes, each which house 4 frames, and a separate box for the signs themselves. All boxes fit on the Archer Trailer for easy transportation. The frames can be matched to any Archer Barrier color for a complete and seamless look. When hit, unsightly traditional signage can act as shrapnel to people and vehicles, The Directional Signage Package allows customers to have a safer and better looking alternative.

**WE OFFER BUYING AND RENTING OPTIONS. GIVE US A CALL TO DISCUSS YOUR NEEDS!**





# MERIDIAN®'s SAFETY Act Designations

Awards by the U.S. Department of Homeland Security:

The SAFETY Act

DESIGNATION as QUALIFIED ANTI-TERRORISM TECHNOLOGY (QATT)

CERTIFICATION for APPROVED PRODUCTS LIST FOR U.S. DEPARTMENT OF HOMELAND SECURITY

**MERIDIAN® Rapid Defense Group has been awarded the highest official recognitions, accreditations and approvals by the U.S. Department of Homeland Security (DHS) pursuant to The SAFETY Act.**

The SAFETY Act creates a liability management system for providers of approved anti-terrorism technologies and products. The SAFETY Act protects MERIDIAN®, its customers, and users of its products from liabilities for claims arising out of an act of terrorism. In the almost twenty-year history of The SAFETY Act, only about 1000 companies have been granted these invaluable protections backed up the U.S. Government.

## PRODUCTS

The MERIDIAN® products and technology covered by these elite awards are the **Archer® 1200 Barrier**, **Archer® Field Tow Bar**, and **Archer® Hauler**. These products and technology form the core of MERIDIAN®'s anti-terrorist vehicle protections and solutions. Use of these Best-in-Industry MERIDIAN® products affords the customer or user the extraordinary SAFETY Act protections from liabilities resulting from acts of terrorism.

## CUSTOMERS

The protections awarded to MERIDIAN® under The SAFETY Act extend to and flow down to all MERIDIAN® customers, suppliers, vendors, users and others in its supply chain from third party claims related to any act of terrorism as determined by DHS. These protections by the U.S. Federal Government are extended to both U.S. and international customers. They also cover acts of terrorism that occur or originate within or outside of the U.S.

## COVERAGE

The protections are truly extraordinary in substance and process. Customers of MERIDIAN® are immune from liability for the use of MERIDIAN® DESIGNATED and CERTIFIED products and technology. MERIDIAN®'s liability is strictly limited to its approved insurance coverage. All claims arising from a terrorist act in any way allegedly involving or impacting MERIDIAN® and its products may only be brought in U.S. Federal Courts. All claims for punitive damages and noneconomic damages are barred.

What this means is that MERIDIAN® will not be destroyed by either the amount of claims or the costs of defending against such claims. MERIDIAN® cannot be forced into faraway courts in another country. MERIDIAN® will be there to service and provide to its customers before and after any act of terrorism. And MERIDIAN®'s customers will also be protected from liability in U.S. Federal Courts with these protections backed up by the obligations of the U.S. Government as established in the formal laws of the U.S. under The SAFETY Act.

MERIDIAN® has been specifically authorized by DHS on behalf of the U.S. Government to inform you—the customers, clients, subcontractors, vendors, and users of MERIDIAN®'s Qualified Anti-Terrorism Technology—that you are immune from liability and claims of liability arising from acts of terrorism. DHS has backed up this message by also specifically authorizing our display of the official marks for DESIGNATION and CERTIFICATIONS under The SAFETY Act as set forth above.



**MERIDIAN®**  
RAPID DEFENSE GROUP

[meridian-barrier.com](http://meridian-barrier.com)



June 20th, 2023

Sergeant Brian Woloski  
Public Safety Police Department  
City of Novi  
45125 Ten Mile Road  
Novi, MI 48375

Brian Woloski,

This is a sole source letter to certify that the Archer 1200 Barrier, the Archer 1200 Trailer Barrier Kit, and the Archer Beam Gate are exclusive MERIDIAN products that are manufactured and sold by Meridian Rapid Defense Group LLC ("MERIDIAN"). MERIDIAN is the creator, manufacturer, and patent holder of these products.

1 Archer 1200 is manufactured in US with 700 lbs. of American made steel and has been tested to MASH, ASTM, PAS 68, and IWA14. No other product on the market meets this standard except the Archer 1200 Barrier.

We are glad to make ourselves available to provide further technical information on materials and the proper use of the above-listed items. MERIDIAN provides the in-field training of the equipment to ensure the safety and effectiveness of the Archer 1200 Barrier.

The following items detail the unique, and one of its kind, characteristics of the Archer 1200 Barrier:

- No other product on the market provides unanchored stopping power certified to US DOD and PAS 68 standards. Unbolted units stop a vehicle traveling 30 mph within 14 feet; no other product on the market meets this standard.
- No other product on the market is rated for armor-piercing NATO ammunition up to .50 cal. ballistic rounds.
- No other barrier on the market is designed as a non-electric and non-hydraulic unit.
- The Archer 1200 Barrier has easily deployable wheels that are self-contained on the barrier and effortlessly positioned. No other product on the market has this unique characteristic.
- No other product on the market can be installed as a complete barrier system with MERIDIAN's 4-foot and 10-foot Arrestor Cables.
- MERIDIAN's unique, one-of-a-kind barriers can be deployed at any desired length, as unit can be "daisy chained" together. This cannot be achieved with any other product on the market.
- MERIDIAN's unique products are transported and positioned using a specially designed Drop Deck Trailer.
- A remaining unique feature of the Archer 1200 Barrier is that the unit allows for the installation of directional or informational signage.

Please feel free to contact me with any specific questions or additional requests for information.

Many thanks,

A handwritten signature in black ink that reads 'J. Eric Alms'.

President

Cell: (626) 755-6493 or (213) 400-9811

[ealms@meridian-barrier.com](mailto:ealms@meridian-barrier.com)

177 E. Colorado Boulevard, Suite 200  
Pasadena, California 91105  
[www.meridian-barrier.com](http://www.meridian-barrier.com)

# MEMORANDUM



**TO:** ERICK E. ZINSER  
DIRECTOR OF PUBLIC SAFETY / CHIEF OF POLICE

**FROM:** BRIAN K. WOLOSKI  
SERGEANT, UNIFORM OPERATIONS 

**SUBJECT:** ARCHER 1200 RAPID DEPLOYMENT BARRICADES BUDGET REQUEST

**DATE:** JUNE 21, 2023

---

The City of Novi has been a host to many major events including the Michigan State Fair, Susan G. Komen Walk for a Cure, Motor City Comic Convention, 5K and 10K races, Island Lake Triathlon, Festival of Chariots, Memorial Day and High School homecoming parades. Past practices for road closures have been to utilize Department of Public Works (DPW) provided Type III and single stage barricades for primary and secondary road closures. These barricades are usually pre-staged by DPW and set up by Novi Officers prior to shutting down roadways and entrance/egress routes. The Type III and single stage barricades provide an effective means for road closure to most drivers who are compliant with the law.

Unfortunately, during our city held events, we have had several occurrences of vehicles disobeying the closures and traveling on the roadways /parking areas. This raises potential risk to participants and spectators at events. There also has been a myriad of world-wide incidents where nefarious individuals, terrorists, home-grown extremists, and those with contaminated thought have caused death, casualties, and destruction during events.

Vehicle-borne ramming attacks are the most common type of vehicle-borne attack in the United States according to the Joint Counter Terrorism Assessment Team (JCAT). In the last several decades there have been approximately 200 vehicle-borne attacks in the world. Since 2020, there have been over a dozen malicious or intentional vehicle-borne attacks in the United States. The April 2020, third issue of the pro-ISIS online magazine Sawt al-Hind gave a call for vehicular attacks as one of the multiple inexpensive and easy ways to attack non-believers. The following list includes some of the most recent vehicle-borne incidents:

January 2018: Charlottesville Virginia, Car rams into crowd at 'Unite the Right' rally killing one and injuring 19.

November 2021: Waukesha Wisconsin, driver of SUV intentionally rams into crowd during a Christmas parade killing five.

May 2022: Deadly Lincoln Nebraska, crash kills two and injures 19 after cars slam into a pedestrian crowd watching a Memorial Day parade.



### Vehicle-Borne Attacks: Mitigation:

The Joint Counter Terrorism Assessment Team (JCAT) has created a First Responders Toolbox which addresses mitigation techniques to thwart vehicle-borne attacks. They purpose a layered security approach which includes traffic management, physical barriers with routine maintenance, and other access controls to restrict and prevent vehicle access without compromising emergency response. The following lists some of the mitigation techniques addressed:

**Deception:** Vehicles modified to replicate official vehicles, drivers using false pretenses to gain access to targeted location

**Mitigation:** Employ layered screening approach that includes visual inspection, use of technology, K-9 specialists.

**Duress:** An individual is forced to grant vehicle access into a secured or restricted area. Or an innocent driver with authorized legitimate access is forced to conduct an attack unwittingly.

**Mitigation:** Use of passive vehicle barriers with established standoff distances.

**Encroachment:** Vehicle may exploit in incomplete or incorrectly spaced security barrier or piggyback a legitimate vehicle through an access point.

**Mitigation:** Establish a layered approach and ensure and ensure appropriate spacing of barriers; block adjacent sidewalks to protect pedestrians; and space vehicles appropriately to prevent piggybacking of vehicles.

**Parked Vehicle-Borne Improvised Explosive Device (VBIED):** Explosive device within a vehicle is located near a target or vulnerable location.

**Mitigation:** Enforce standoff between potential targets and authorized parking. Utilize mirrors to check under vehicles and explosive detection canines to locate hidden devices.

**Penetrative:** A vehicle is used to weaken or breach a perimeter in order to get a vehicle closer to the intended target.

**Mitigation:** Hinder access or limit speed through bends, chicanes (serpentine), and offset approaches; use traffic calming measures. And establish standoff distances from the target and vehicle security barriers (gates, bollards, public art, water features, seating, street furniture, fences, ditches, topography or landscaping and raised planters).

The JCAT also lists several considerations regarding a collective approach between government and industry stakeholders who can ensure an effective and proportionate response to prevent vehicle-borne attacks or minimize the effects.

- A combination of architectural design and traffic movement engineering can improve site security measures to channel a vehicle's movement, and reduce a vehicle's momentum.
- A shared understanding among all security stakeholders of current terrorist tactics aids in the development of tailored security assists and inform risk and vulnerability assessments, as the threat evolves.

- Understand the changes in landscape, construction, land development, traffic flow, adjacent streets, and other approach avenues such as multi-use paths, bike lanes, and pedestrian crosswalks.

**Event Planning:** Special events and their associated security footprints often encompass not only a central location or venue, but also much of the surrounding area, including adjacent buildings, roads, sidewalks, multi-use paths, and mass transit.

- Consider pedestrian friendly streetscapes, physical security measures, and conventional traffic principles to prevent vehicle access or limit proximity to the site by closing as many roads as possible in the surrounding area of the event.
- Crowds may have to be screened prior to the event entry. Flows of people typically bottleneck at the predictable locations such as security checkpoints and public transit stations.
- Anticipate locations where large crowds might not regularly gather.
- Review security modifications to ensure emergency response routes are not impeded.
- Ensure all potential security and response stakeholders are familiar with changes made to venue and its surrounding areas.

**Vehicle Barriers:** Can be passive (static), active (operable), re-deployable, and improvised. The appropriate use, type, and location of vehicle barriers may require a site assessment, traffic engineering study, and site survey. When deciding vehicle barrier types (bollards, trees, street art), consider intended use, routine maintenance needs and costs, accessibility and safety.

- Passive security barriers include landscape features, large immovable landmarks, integrated street furniture, level changes (high curbs or steps), water features, vegetation, chain link fences supplemented with high-strength cables, and concrete walls.
- Active barriers include the use of retractable bollards and raising arm gates that can be used if legitimate vehicle access is required past the standoff perimeter.
- Re-deployable barriers are quick to set up and used during a short notice event or during an increased threat to a planned event.
- Improvised barriers such as large vehicles, are used to fill gaps and control access to roadways, sidewalks or paths. Consider the size, weight, and placement of improvised barriers relative to the potential threat.

#### Future Event Planning:

Vehicle-borne attacks, both intentional and unintentional, are a possibility and should be planned for at all major events. The City of Novi recently organized and hosted a Memorial Day 5K run and parade after which an after-action review was conducted. Recommendations were made as to limiting the length of the parade route due to the inability to secure and control vehicle access across the entire route. Further recommendations were made regarding the acquisition of rapid deployment barricades which can be used to mitigate or hinder access and control vehicle and or pedestrian movement at future events. Meridian Rapid Defense Group provided seven Archer 1200

vehicle barriers which were utilized at the Memorial Day parade. The barricades were placed on Ten Mile Road West of Novi Way to prohibit vehicle movement eastbound towards the parade.

Archer 1200 Vehicle Barrier:

The Archer 1200 vehicle barrier is a 700-pound individual portable barrier system that can be moved by one adult with the use of a designated dolly. The Archer 1200 requires no maintenance, electricity, hydraulics, or batteries. The Archer 1200 portable barrier system is designed to stop moving vehicles upon impact with the system. It can be configured with multiple barriers to control movement of vehicles and pedestrians, prohibit access, and enforce standoff. The Archer 1200 portable barrier is on the approved products list for the Department of Homeland Security and is in use across the United States by multiple law enforcement agencies. Archer 1200 portable barricades are 100% reusable after impact and have a lifetime warranty.

Budget Request:

The Novi Police Department would like to procure sixteen Archer 1200 portable barricades with an Archer 8-barrier drop deck trailer. These barricades will be utilized during events held in the City of Novi for the safety and protection of citizens. The Archer 1200 portable barricades would allow the Novi Police Department to enhance its security capabilities as outlined in the Joint Counter Terrorism Assessment Team's (JCAT) vehicle-borne attack mitigation first responder's toolbox.

The attached quote from Meridian Rapid Defense Group addresses the Novi Police Departments current inability to provide a proper layered approach to event security. The following is a list of the requested items from Meridian Rapid Defense Group:

<b>8 Barrier Trailer Kit with trailer</b>	(1)	\$84,664.34	\$84,664.34
<b>Archer 1200 Barrier</b>	(8)	6,513.75	
<b>Archer Hauler</b>	(1)	1,925.18	
<b>Archer Field Tow Bar</b>	(2)	574.18	
<b>Arrestor Cable (4ft)</b>	(7)	574.18	
<b>Arrestor Caba (10ft)</b>	(2)	670.68	
<b>Archer 8-Barrier Drop Deck Trailer</b>	(1)	24,120.18	
<b>Archer 1200 Barrier Kit- no trailer</b>	(8)	6,513.75	52,110.00
<b>Archer Hauler</b>	(1)	1,925.18	1,925.18
<b>Archer Field Tow Bar</b>	(2)	574.18	1,148.36
<b>Arrestor Cable (4ft)</b>	(7)	574.18	4,019.26
<b>Arrestor Caba (10ft)</b>	(2)	670.68	1,341.36
<b>In-Field Installation and Certified Training</b>		1,442.68	1,442.68
<b>Freight/Shipping</b>		8,995.00	8,995.00
		<b>Total:</b>	<b>\$155,646.18</b>

Michigan Agencies Utilizing the Product:

There are several State of Michigan law enforcement agencies in the quote/purchasing process for the Archer 1200 barricade system. The following agencies are currently utilizing Archer 1200 barricades:

- Auburn Hills Police Department
- Holland Police Department
- Grand Haven Police Department
- Zeeland Police Department
- Ferndale Police Department
- Farmington Hills Police Department
- Oakland County Tactical Training Consortium





