



**CITY OF NOVI CITY COUNCIL
DECEMBER 18, 2023**

SUBJECT: Consideration of approval to award our currently contracted vendor, American Generator Sales and Service, LLC, the City of Novi Fire Station #2 and Fire Station #3 generator replacement project in the amount of \$163,311.09.

SUBMITTING DEPARTMENT: Public Safety and Integrated Solutions

EXPENDITURE REQUIRED	\$163,311.09
AMOUNT BUDGETED	\$163,500.00
APPROPRIATION REQUIRED	\$0
LINE ITEM NUMBER	101-265.00-976.150

BACKGROUND INFORMATION:

The current Cummins generators and automatic transfer switches (ATS) located at Fire Station #2 and Fire Station #3 were manufactured in 2001. Both generators are identical and supply 35kW of energy to each building in the event of a power outage.

In early 2023, back-to-back ice storms resulted in multiple days without power at both locations. While both backup generators started running during the outage, they could not supply power to the entire building, which forced us to utilize a second temporary generator. After performing load test studies on each generator and calculating energy requirements for each building, it was determined that the current 35kW generators are drastically underpowered. As a result, the existing generators were never configured to supply power to a second breaker panel that runs essential items in the living space areas including heat, lighting, and outlets. Configuring the current generators to power the entire building would put them at over 100% capacity.

The attached quotes for consideration are to replace the generators at Fire Station #2 and Fire Station #3, including the automatic transfer switches. The replacement generator for Fire Station #2 is a Blue Star 60kW generator while the latter is a Blue

Star 50kW generator. Each replacement generator and ATS is spec'd to supply power to the entire building including essential items based on the studies from each location. The total cost includes removal and disposal of the current units, installation, new concrete pads, connection to the existing gas lines, permits, training, and the re-installation of our GenTracker system which was installed in 2022 and is compatible. Installation of both units will be provided by American Generator Sales and Service, LLC which is currently under contract with the City of Novi to perform all of our generator service needs. The Blue Star generator brand comes with a 2-year 2000-hour warranty and matches those recently installed at Meadowbrook Commons and DPW.

RECOMMENDED ACTION: Consideration of approval to award our currently contracted vendor, American Generator Sales and Service, LLC, the City of Novi Fire Station #2 and Fire Station #3 generator replacement project in the amount of \$163,311.09.



American Generators Sales & Service, LLC

6158 Delfield Drive, Ste. C

Waterford, MI 48329

Phone: (248) 623-4919 Fax: (248) 623-4918

August 10, 2023

City of Novi

Fire Station #2

1919 Paramount, Novi, MI 48377

REF: 60 kW Generator Installation Project

ATTN: Matt Turco

Mr. Turco,

Thank you for your interest in American Generators Sales & Service, LLC, products and services.

Below is a description of the Scope of Work for installing a "Standby Natural Gas Generator System" for above mentioned building

This System will allow complete power backup of the mentioned building, in its entirety.

This Scope is based on our conversations, site visit, and meeting with yourself. Please review this document and contact me with any questions.

SCOPE of WORK:

Provide and install the following:

- Blue Star PS60 (See Attached Spec Sheet)
 - 120/240V
 - Level 1 Weather Enclosure
 - 10A 12V Premium Battery Charger
 - Coolant Heater
- Concrete Pad – Per Manufacturers Specs
- Electrical Materials
- Gas Line Materials
- Labor
- Electrical Permit
- Mechanical Permit
- Freight / Delivery / Crane Service
- Project Commissioning & Testing
- Owners Training
- Project Close-out (Drawings, Manuals, Documentation, etc.)
- Reinstall existing Remote System Monitoring (cellular based) - Remote Start Capable Monitoring. (Annual Subscription of \$365.00) First Year Monitoring is Included. (optional, but included)
- Sales tax EXEMPT

NOT INCLUDED IN TOTAL PRICE

- Overtime

BLUE ST★R

Power Systems Inc.

Submittal

4/12/2023

Project Title	CoN FS#2
Quote Number:	0095489-0
Model:	GM60-02

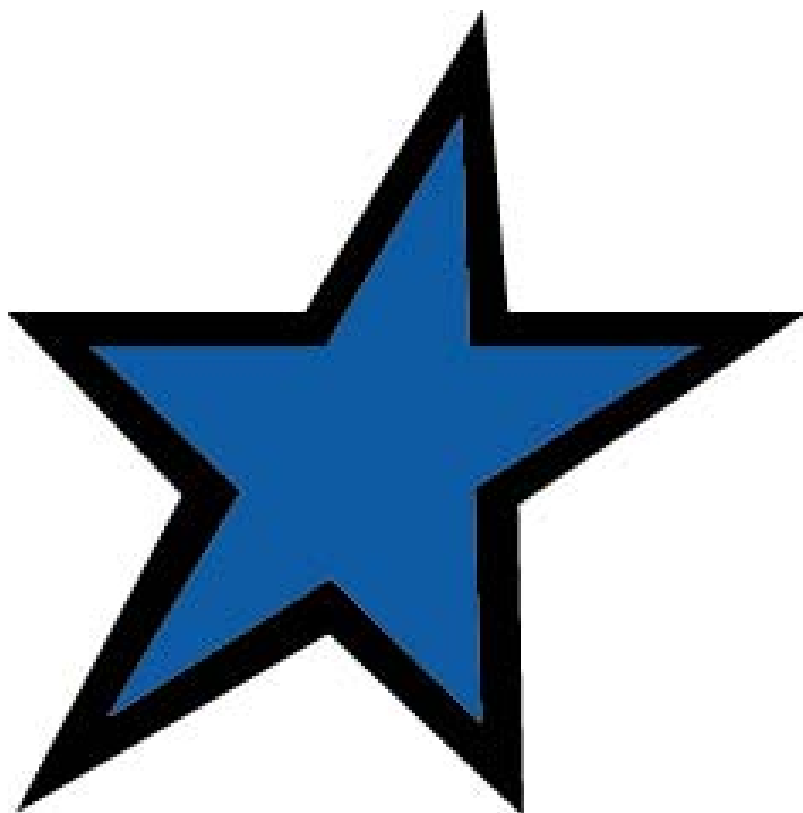

American Generators Sales & Service, LLC.
Doug Pletcher
6158 Delfield Dr.
Suite C
Waterford MI 48329
Office: 248-623-4919
Cell: 248-240-6036
Email: dpletcher@american-generator.com

BLUE STAR

Power Systems Inc.

Table of Contents

- Sales Quote
- Specification Sheet
- 5.7L Data Sheet
- 11 Industrial Alternators
- 14 MX321 Voltage Regulator
- DCP7310 ControlPanel
- 6 DSE2548 Remote Annunciator
- 44 Paint and Powder Coat
- 19 Enclosures
- 17 Radiators
- 22 Circuit Breakers
- 29 TPS Series Block Heaters
- 31 Single Stage Air Cleaner
- 33 CPJ Series Silencers
- 27 Industrial Batteries
- 26 Deep Sea Battery Charger
- 47 Factory Load Test
- 2yr 2000hr limited warranty

BLUE STAR

Power Systems Inc.

Sales Quote

Quote Date: 4/12/2023 1:46:28 PM
Quote Number: 0095489-0
Project Title: CoN FS#2
Prepared for: American Generators Sales & Service, LLC.

Distributed by:



Unit Model	GM60-02	Standby / Prime	Emergency Stationary Standby
kWe Rating	60 kWe	UL 2200 Listed	Yes
Fuel	Natural Gas [NG]	CSA Approved	Yes
EPA	Certified	Paint Color	Gray

Fuel System: Natural Gas

Engine Model: General Motors 5.7L EPA 60kW Standby Power Rating at 1800 RPM Governor - Electronic Isochronous

Voltage: 240/120V 3 Phase 60 Hz 0.8 PF

Gen Model: Stamford UCI224F 12 Lead Wired 240V 3 Phase Delta 125°C Rise Over 40°C Ambient

Voltage Regulator: Stamford MX321 Automatic Voltage Regulator with PMG Excitation

Control Panel: Blue Star DCP7310 Microprocessor Based Gen-Set Controller Mounted Facing Left from Generator End (Unless Specified Otherwise)
Standard Features: Low Oil Pressure, High Coolant Temp, Overspeed, Overcrank Shutdowns
Emergency Stop Pushbutton, Audible Alarm Buzzer with Silencing Switch

Control Panel Options: Low Water Level Sensor with Shutdown

Remote Annunciator: Deep Sea DSE2548 (2x) Remote Annunciator with Enclosure (Surface Mounted)

Unit Color: Gray

Enclosure: Level 3 (Sound Attenuated Enclosure) Powder Coated 14 Gauge Steel Rugged and Durable 200 MPH Wind Rated Enclosure with Exhaust Hood Pitched Roof for Increased Structural Integrity and Improved Watershed Punched Intake with Baffle and Punched Exhaust Openings Keyed Alike Lockable Doors with Draw Down Latches and Stainless Steel Component Hinges Additional 1.5" Thick Polydamp Type D Acoustical Foam (PAF) Formed Steel Base with Mounting and Lifting Holes Includes Vibration Mounts to Isolate Unit from Base Rail

Sound Attenuation Foam: Sound Attenuation Installed in Enclosure and Exhaust Hood

Cooling: Unit Mounted Radiator (50°C Ambient)

Coolant Drain Extension: Plumbed to Bulkhead Fitting in Base

Oil Drain Extension: Plumbed to Bulkhead Fitting in Base

Mainline Breaker: 200 Amp 3 Pole 240 Volt Breaker Mounted & Wired in a NEMA 1 Enclosure

Jacket Water Heater: Engine Block Heater 1500W 120VAC Rated for -20°F Heater Installed with Isolation Valves and Wired to Terminal

Air Cleaner: Dry Single Stage

Silencer: Critical Grade Compact (CPJ Series) Silencer Mounted to Engine

Battery: 12 Volt System with Rack and Cables

Battery Charger: DSE 12 Volt 10 Amp Mounted and Wired to Terminal

Factory Test: Standard Commercial Testing Includes:
Verification of Alarm Shutdowns, Voltage Settings, Block Loading to Rated kWe and PF

Owner's Manual: Print Copy (Qty 1) **Standard**, Electronic Copy, Flash Drive (Qty 1)

Warranty: 2 Year / 2000 Hour Limited

Notes:

**Additional Options
(Not Included in Price):**

ATS 1

Series	300	Volts	240/120V 3 PH
Service Entrance Rated	Yes	Poles	3
Amps	400	Enclosure	Nema 3R Secure

Warranty: Two (2) Year Basic ATS Limited Warranty Standard

Optional Accessories: 44G Strip Heater with Thermostat, Wired to Load Terminals (208-600V)
11BE Feature Bundle Includes Engine Exerciser/Event Log/RS-485 Enabled/Common AI

ATS Notes:

Payment Terms: Due Upon on Receipt

Lead Time: 40 + Weeks

Payment Terms: Due Upon Receipt

Delivery Schedule: 40 Weeks (Contingent on component availability)

Terms & Conditions

- This quote is valid for a period of 15 days.
 - This proposal is our interpretation of your requirement. It includes only the items listed on this quotation. Should there be other requirements or specifications, we will re-quote accordingly.
 - Units are shipped wet to include lube oil and 50/50 water and antifreeze mix unless otherwise noted in this quotation.
 - All extended piping, wiring, or other than listed above is performed by "others".
 - Seller is not quoting, offloading, job site startup, personnel instructions, field testing, or unit installation.
 - Quoted prices include normal testing, packaging, and instructional literature.
 - It is the distributor/purchaser and end user's responsibility to ensure that this equipment is operated in accordance with all applicable local, state, and federal laws and regulations governing the use and operation of this equipment.
-

Distributor Terms & Conditions

PAYMENT TERMS:

- 20% DOWN AT TIME OF ORDER PLACEMENT, 70% AT TIME OF EQUIPMENT DELIVERY, 10% NET 30 DAYS OR BY START UP, WHICHEVER COMES FIRST.
- TERMS BASED ON CREDIT APPROVAL.
- ALL LATE PAYMENTS WILL BE SUBJECT TO A SERVICE FEE OF 1.5% PER MONTH. CUSTOMER WILL BE RESPONSIBLE FOR ANY AND ALL COLLECTION COSTS, INCLUDING LEGAL FEES.
- ALL CREDIT CARD PAYMENTS WILL INCUR A 3% TRANSACTION FEE.

I HAVE READ AND INITIALED, AGREEING TO TERMS _____

TAX EXEMPT NO. _____ IF APPLICABLE

F.O.B. FREIGHT ALLOWED TO JOB SITE, CUSTOMER TO OFFLOAD

DELIVERY: TO BE DETERMINED AT TIME OF ORDER.
TENTATIVE DELIVERY IS BASED ON THE MANUFACTURER'S CURRENT LEAD-TIME;

THIS IS NOT A GUARANTEE TO SHIP AND SHOULD BE USED FOR PLANNING PURPOSES ONLY.

CANCELLATION CHARGES WILL APPLY. ORDERS IN PRODUCTION BY THE MANUFACTURER CANNOT BE CANCELLED.

ALL EQUIPMENT REMAINS THE PROPERTY OF AMERICAN GENERATORS SALES& SERVICE, LLC. UNTIL PAID IN FULL

ACCEPTED BY: SITE ADDRESS:

COMPANY _____

AUTHORIZED SIGNATURE TO RELEASE MATERIAL _____

PRINT NAME _____ DATE _____

BLUE STAR

Power Systems Inc.

Gaseous Product Line

208-600 Volt

GM60-02

60 Hz / 1800 RPM

60 kWe

Standby

Ratings

	240V	208V	240V	480V	600V
Phase	1	3	3	3	3
PF	1	0.8	0.8	0.8	0.8
Hz	60	60	60	60	60
Generator Model	UCI224G	UCI224F	UCI224F	UCI224E	UCI224E
Connection	12 LEAD DD	12 LEAD WYE	12 LEAD DELTA	12 LEAD WYE	4 LEAD WYE
kWe Nat (LP)	60 (60)	60 (60)	60 (60)	60 (60)	60 (60)
AMPS Nat (LP)	250 (250)	208 (208)	181 (181)	90 (90)	72 (72)
Temp Rise	125°C / 40°C	125°C / 40°C	125°C / 40°C	125°C / 40°C	125°C / 40°C

Standard Equipment

Engine

- Radiator Cooled Unit Mounted (50°C)
- Radiator Duct Flange (OPU Only)
- Blower Fan & Fan Drive
- Starter & Alternator
- Oil Pump & Filter
- Oil Drain Extension w/Valve
- Governor - Electronic Isochronous
- 12V Battery System & Cables
- Air Cleaner (Dry Single Stage)
- Critical Grade Silencer Mounted
- Flexible Fuel Connector
- EPA Certified

Generator

- Brushless Single Bearing
- Automatic Voltage Regulator
- ± 1% Voltage Regulation
- 4 Pole, Rotating Field
- 125°C Standby Temperature Rise
- 100% of Rated Load - One Step
- 5% Maximum Harmonic Content
- NEMA MG 1, IEEE and ANSI Standards Compliance for Temperature Rise

Additional

- Single Source Supplier
- UL 2200 & cUL Listed
- CSA Certified
- Seismic Certified to IBC 2021
- NFPA 110 / CSA C282 Compliant
- Microprocessor Based Digital Control Panel Mounted in NEMA 12 Enclosure
- Base - Formed Steel
- Main Line Circuit Breaker Mounted & Wired
- Battery Charger 12V 6 Amp
- Jacket Water Heater -20°F 1500W 120V w/Isolation Valves
- Vibration Isolation Mounts
- 2YR / 2000HR Standby Warranty
- Standard Colors - White / Gray

Application Data

Engine

Manufacturer:	Power Solutions International	Displacement - Cu. In. (lit):	350 (5.70)
Model:	5.7L NA	Bore - in. (cm) x Stroke - in. (cm):	4.00 (10.2) x 3.48 (8.84)
Type:	4-Cycle	Compression Ratio:	9.40:1
Aspiration:	Natural	Rated RPM:	1800
Cylinder Arrangement:	8 Cylinder Vee	Max HP Stby (kWm):	113 (84.3)

Exhaust System

	Standby
Gas Temp. (Stack): °F (°C)	1,350 (732)
Gas Volume at Stack Temp: CFM (m³/min)	553 (15.7)
Maximum Allowable Exhaust Restriction: in. H ₂ O (kPa)	40.8 (10.2)

Cooling System

Ambient Capacity of Radiator: °F (°C)	122 (50.0)
Maximum Allowable Static Pressure on Rad. Exhaust: in. H ₂ O (kPa)	0.50 (0.12)
Water Pump Flow Rate: GPM (lit/min)	36.6 (139)
Heat Rejection to Coolant: BTUM (kW)	3,120 (54.6)
Heat Rejection to CAC: BTUM (kW)	N/A
Heat Radiated to Ambient: BTUM (kW)	802 (14.0)

Air Requirements

Aspirating: CFM (m³/min)	173 (4.90)
Air Flow Required for Rad. Cooled Unit: CFM (m³/min)	7,400 (209)
Air Flow Required for Heat Exchanger/Rem. Rad. CFM (m³/min)	Consult Factory For Remote Cooled Applications

Fuel Consumption

	Natural Gas	LP
At 100% of Power Rating: ft ³ /hr (m ³ /hr)	773 (21.9)	339 (9.59)
At 75% of Power Rating: ft ³ /hr (m ³ /hr)	663 (18.8)	258 (7.30)
At 50% of Power Rating: ft ³ /hr (m ³ /hr)	545 (15.4)	213 (6.03)
Fuel Inlet Size: NPT		1.00"
Fuel Pressure Required: in. H ₂ O (kPa)		11.0 (2.75)

Fluids Capacity

Total Oil System: gal (lit)	1.25 (4.73)
Engine Jacket Water Capacity: gal (lit)	2.03 (7.68)
System Coolant Capacity: gal (lit)	6.00 (22.7)

All calculations based on natural gas fuel.

Deration Factors: Temperature: Derate 1% Per 10°F Over 77°F Air Inlet Temperature | Altitude: Derate 3% Per 1,000 ft Over 1,200 ft

DCP7310 Control Panel

Standard Features

- Digital Metering
- Engine Parameters
- Generator Protection Functions
- Engine Protection
- CAN Bus (J1939) ECU Communications
- Windows-Based Software
- Multilingual Capability
- Remote Communications to DSE2548 Remote Annunciator
- 8 Programmable Contact Inputs
- 10 Contact Outputs
- RS485 Communicator Interface
- cULus Listed, CE Approved
- Event Recording
- IP 65 rating (with supplied gasket) offers increased resistance to water ingress
- NFPA 110 Level 1 Compatible

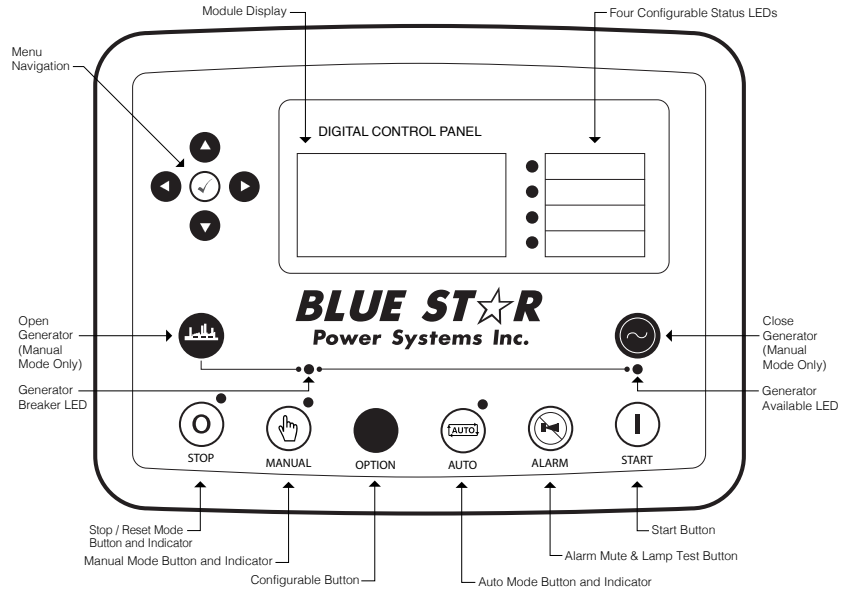

Weights / Dimensions / Sound Data

	L x W x H	Weight lbs
OPU	80 x 38 x 52 in	1,900
Level 1	90 x 38 x 60 in	2,375
Level 2	90 x 38 x 60 in	2,400
Level 3	120 x 38 x 60 in	2,550

Please allow 6-12 inches for height of exhaust stack.

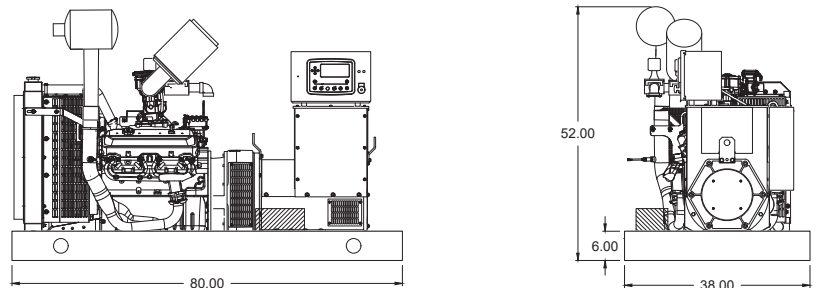
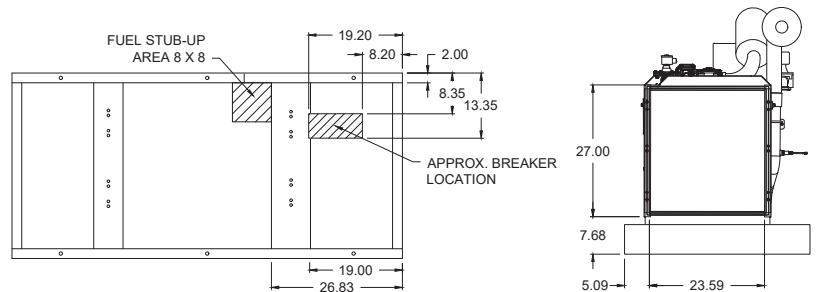

	No Load	Full Load
OPU	76 dBA	79 dBA
Level 1	71 dBA	73 dBA
Level 2	66 dBA	68 dBA
Level 3	63 dBA	64 dBA

Enclosures

Level 1 & 2 | Side View (Weather Proof)

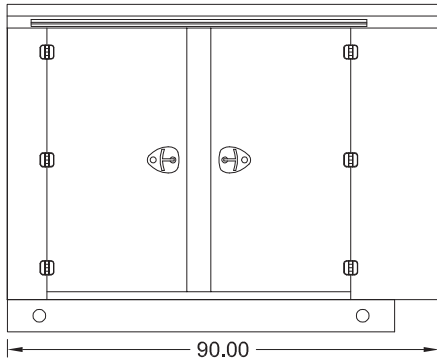

Level 3 | Side View (Sound Attenuated)

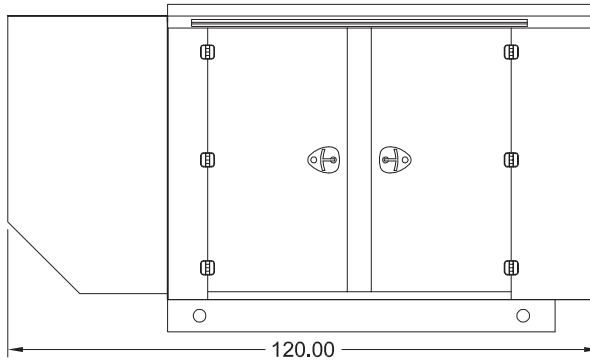

Level 1, 2 & 3 | Intake View

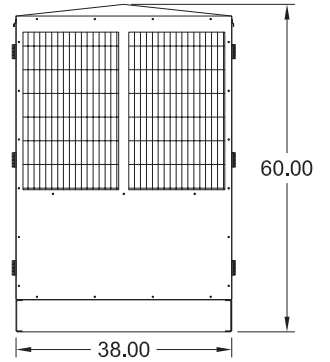

- All enclosure models are 200 MPH wind rating certified in accordance with IBC2021 and ASCE/SEI 7-16 standards.
- Level 2 & 3 enclosures include sound attenuation foam
- Level 3 enclosure includes frontal sound & exhaust hood.
- Enclosure height does not include exhaust stack.

Notes

- All specification sheet dimensions are represented in inches.
- All drawings based on standard 480 volt standby generator. Lengths may vary with other voltages. All drawings and dimensions subject to change without notice.
- All enclosures are based on the standard unit configuration. Any requested deviation can change dimensions.
- Sound data is measured at 23 feet (7 meters) in accordance with ISO 8528-10.
- All materials and specifications subject to change without notice.

American Owned



American Made

Blue Star Power Systems, Inc.

2250 Carlson Drive

North Mankato, Minnesota 56003

Phone + 1 507 345 1776

bluestarps.com

quote.bluestarps.com

sales@bluestarps.com



5.7L Naturally Aspirated Stationary

EMERGENCY "STANDBY"



Date:	10/28/2014
Rev:	C

Units		5.7L NA			
Std	Metric	1500		1800	

General Engine Data						
Type	N/A		GM V-Type 4 Cycle			
Number of cylinders	N/A		8			
Aspiration	N/A		Naturally Aspirated			
Bore	in	mm	4	101.6	4	101.6
Stroke	in	mm	3.48	88.4	3.48	88.4
Displacement	in ³	L	350	5.7	350	5.7
Compression Ratio	N/A		9.4:1			
RPM Range (Min-Max)	RPM		1500-1800			
Rotation Viewed from Flywheel	N/A		Counter Clockwise			
Firing Order	N/A		1-8-4-3-6-5-7-2			
Dry Weight (long Block)	lb	kg	432	196	432	196
Gross Standby Power Rating ^{1,2,3} Per ISO 3046 at the Flywheel			HP	KW	HP	KW
LP			94.30	70.32	113.16	84.38
Standby Rating Average Load Factor - LP			77.32	57.66	92.79	69.19
NG			87.28	65.08	104.73	78.10
Standby Rating Average Load Factor - NG			71.56	53.36	85.87	64.04
Please ask a PSI sales representative for information regarding prime power operation						
Exhaust System						
Type			Air Cooled Manifold			
Emergency Standby Rating Catalyst Configuration for US Certified Product			No Catalyst		No Catalyst	
Maximum allowable Back pressure	in HG	kPa	3	10.2	3	10.2
Exhaust Volumetric Flow at Rated Power @ 1350 F	cfm	m ³ /min	470.5	13.32	552.7	15.82
Air Induction System						
Maximum allowable Intake Air Restriction with Air Cleaner						
Clean	inH ₂ O	kPa	3	1.49	3	1.49
Dirty	inH ₂ O	kPa	13	3.24	13	3.24
Combustion Air required (volume)	cfm	m ³ /min	145.70	4.13	173.00	4.90
Cooling System						
Coolant Capacity						
Engine only	qts	L	8.1	7.8	8.1	7.8
Heat rejected to Cooling water at rated Load	btu/min	kcal/sec	2600	12.8	3120	13.1
Cracking Temperature	F	C	160	71	160	71
Full Open Temperature	F	C	185	85	185	85
Lubrication System						
Oil Specification			SAE 5W-30 API Rating of SM or Newer			
Maximum Allowable Oil Temperature	F	C	250	121	250	121
Engine Oil Capacity						
Min	Qts	L	5	4.7	5	4.7
Max	Qts	L	5	4.7	5	4.7
Fuel System						
Fuel Consumption @ Rated Load						
NG	lb/hr	kg/hr	33.9	15.37	38.2	17.32
LP	lb/hr	kg/hr	38.2	17.32	42.1	19.09
Maximum EPR Rated Pressure	psi	kPa	1.0	6.9	1.0	6.9
Recommended Maximum Running pressure to Electronic Pressure Regulator (EPR)	inH ₂ O	kPa	20.0	2.7	11.0	2.7
Recommended Minimum Running pressure to EPR	inH ₂ O	kPa	7.0	1.7	7.0	1.7
Minimum NG Supply Pipe Size			1-1/4" NPT			
Minimum LPG Supply Pipe Size ⁴			3/4"			

¹ Standby and overload ratings based on ISO 3046. See PSI technical standard 3630000A for additional duty cycle and engine rating information

² All ratings are gross flywheel horsepower corrected to 77°F at an altitude of 328feet with no cooling fan or alternator losses using heating value for NG of 1015 BTU/SCF.

³ Production tolerances in engines and installed components can account for power variations of +/- 5%. Altitude, temperature and excessive exhaust and intake restrictions should be applied to power calculations.

⁴ The preceding pipe sizes are only suggestions and piping sizes may vary with temperature, pressure, distance from supply and application of local codes. Gas must be available at adequate volume and pressure for engine at the EPR.

For information not listed in this document, please contact you PSI sales representative



**POWER SOLUTIONS
INTERNATIONAL**

201 Mittel Dr. Wood Dale, IL 60191
(630) 350-9400 Tel. • (630) 350-9900 Fax

PSI Technical Standard 36300000A- Engine Rating Guidelines

Emergency Standby Power Rating: Applicable for supplying emergency power for the duration of utility power outage. There is no overload capability for the emergency standby rating. Any use of the generator above the emergency standby rating is prohibited. Any unit operating in parallel with a public utility is not considered emergency standby. Emergency standby engine is applicable to a variable load with a maximum average load factor of 82% and 200 hours of operation per year. Emergency standby rating should only be applied in emergency power outages.

Prime Power Rating: Applicable for supplying electrical power in lieu of commercially purchased power or providing guaranteed standby power. The prime power rating is applicable for variable loads with limited number of operating hours per year. The average power output shall not exceed 75% of the prime power rating. The total time at 100% Prime power shall not exceed 500 hours per year. A 110% overload rating is available one hour in every twelve hours with the total hours at 110% not to exceed 25 hours per year. Maximum number of hours per year is 2500.

Continuous Power Rating: The continuous power rating is applicable for variable loads with unlimited number of operating hours per year. The power output shall not exceed 75% of the prime power rating. There is no overload capability.

Blue Star Power Systems, Inc. utilizes the highest quality alternators available. Our industrial alternators provide consistent performance, quality design, and great durability required for long life and versatility. Alternators used by Blue Star Power Systems, Inc. are UL and CSA Listed, which guarantees that each one meets the rigorous demands of industrial power generation and will provide safe and effective service for the life of the alternator. Blue Star Power Systems, Inc. alternators range from 20 kWe through 2000 kWe.



Standard Features

- **Enhanced Ventilation**
Created by a high-efficiency fan that optimizes internal airflow patterns, maximizes heat transfer, and minimizes hot spot differentials for extended winding life.
- **Fully Guarded**
For operator safety and alternator protection. No rotating or electrically energized parts are exposed. All openings are covered by louvers or screens.
- **Large Conduit Box**
Provides ample space for easy connections and allows load line access from all sides, top, or bottom.
- **Design Specs and Agency Approvals**
All Blue Star Power Systems, Inc. alternators are UL and CSA Listed (unless specified otherwise) and meet NEMA MG1-32, BS5000, CSA C22.2, IEC 34 and VDE 0530 requirements.
- **Class H Insulation System**
Utilizes an unsaturated polyester varnish for optimal insulation life and superior moisture protection.
- **Optimized Windings**
Provide low reactances and exceptional motor starting capability. The stator windings utilize a 2/3 pitch to minimize harmonic distortion and facilitate parallel operation.
- **Permanent Magnet Generator (optional)**
Ensures 300% short circuit current during fault conditions and provides the regulator with input power isolated from load distortion.
- **Heavy-Duty Bearing**
Resists contamination and gives a life expectancy up to 40,000 hours.
- **Automatic Voltage Regulator**
Provides accurate 1% regulation, under-speed protection, stability adjustment to optimize transient performance, and EMI filtering to commercial standards. Fully encapsulated for rugged durability in virtually any environment.

STAMFORD®

UCI224F - Winding 311

Technical Data Sheet

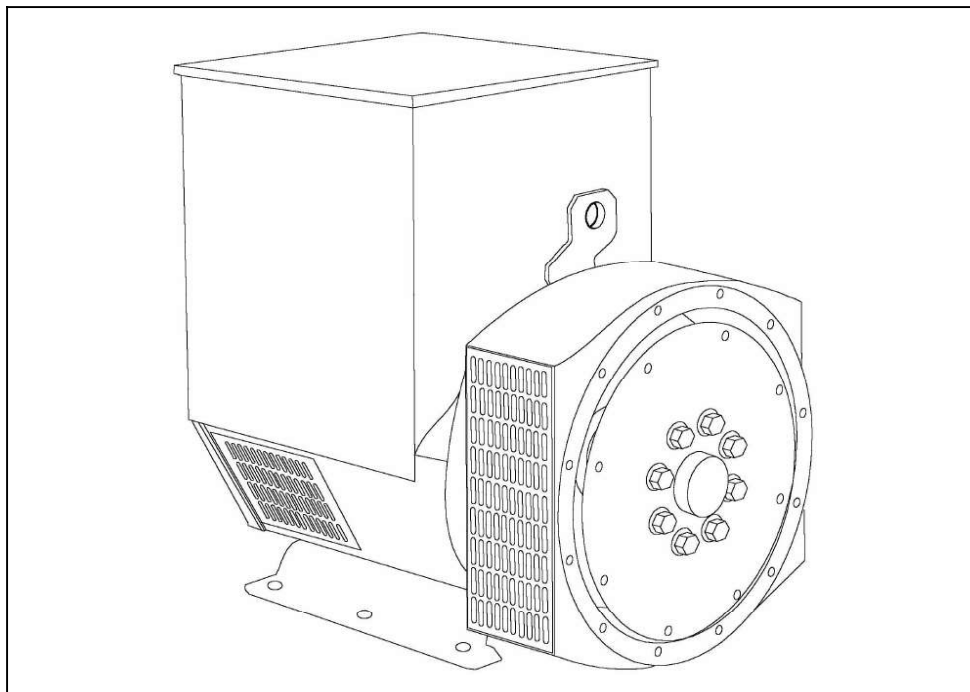

SPECIFICATIONS & OPTIONS**STANDARDS**

Stamford industrial generators meet the requirements of BS EN 60034 and the relevant section of other international standards such as BS5000, VDE 0530, NEMA MG1-32, IEC34, CSA C22.2-100, AS1359.

Other standards and certifications can be considered on request.

VOLTAGE REGULATORS**SX460 AVR - STANDARD**

With this self excited control system the main stator supplies power via the Automatic Voltage Regulator (AVR) to the exciter stator. The high efficiency semiconductors of the AVR ensure positive build-up from initial low levels of residual voltage.

The exciter rotor output is fed to the main rotor through a three phase full wave bridge rectifier. This rectifier is protected by a surge suppressor against surges caused, for example, by short circuit.

AS440 AVR

With this self-excited system the main stator provides power via the AVR to the exciter stator. The high efficiency semiconductors of the AVR ensure positive build-up from initial low levels of residual voltage.

The exciter rotor output is fed to the main rotor through a three-phase full-wave bridge rectifier. The rectifier is protected by a surge suppressor against surges caused, for example, by short circuit or out-of-phase paralleling.

The AS440 will support a range of electronic accessories, including a 'droop' Current Transformer (CT) to permit parallel operation with other ac generators.

MX341 AVR

This sophisticated AVR is incorporated into the Stamford Permanent Magnet Generator (PMG) control system.

The PMG provides power via the AVR to the main exciter, giving a source of constant excitation power independent of generator output. The main exciter output is then fed to the main rotor, through a full wave bridge, protected by a surge suppressor. The AVR has in-built protection against sustained over-excitation, caused by internal or external faults. This de-excites the machine after a minimum of 5 seconds.

An engine relief load acceptance feature can enable full load to be applied to the generator in a single step.

If three-phase sensing is required with the PMG system the MX321 AVR must be used.

We recommend three-phase sensing for applications with greatly unbalanced or highly non-linear loads.

MX321 AVR

The most sophisticated of all our AVRs combines all the features of the MX341 with, additionally, three-phase rms sensing, for improved regulation and performance.

Over voltage protection is built-in and short circuit current level adjustments is an optional facility.

WINDINGS & ELECTRICAL PERFORMANCE

All generator stators are wound to 2/3 pitch. This eliminates triplen (3rd, 9th, 15th ...) harmonics on the voltage waveform and is found to be the optimum design for trouble-free supply of non-linear loads. The 2/3 pitch design avoids excessive neutral currents sometimes seen with higher winding pitches, when in parallel with the mains. A fully connected damper winding reduces oscillations during paralleling. This winding, with the 2/3 pitch and carefully selected pole and tooth designs, ensures very low waveform distortion.

TERMINALS & TERMINAL BOX

Standard generators are 3-phase reconnectable with 12 ends brought out to the terminals, which are mounted on a cover at the non-drive end of the generator. A sheet steel terminal box contains the AVR and provides ample space for the customers' wiring and gland arrangements. It has removable panels for easy access.

SHAFT & KEYS

All generator rotors are dynamically balanced to better than BS6861:Part 1 Grade 2.5 for minimum vibration in operation.

INSULATION/IMPREGNATION

The insulation system is class 'H'.

All wound components are impregnated with materials and processes designed specifically to provide the high build required for static windings and the high mechanical strength required for rotating components.

QUALITY ASSURANCE

Generators are manufactured using production procedures having a quality assurance level to BS EN ISO 9001.

The stated voltage regulation may not be maintained in the presence of certain radio transmitted signals. Any change in performance will fall within the limits of Criteria 'B' of EN 61000-6-2:2001. At no time will the steady-state voltage regulation exceed 2%.

DE RATES

All values tabulated on page 8 are subject to the following reductions

5% when air inlet filters are fitted.

3% for every 500 metres by which the operating altitude exceeds 1000 metres above mean sea level.

3% for every 5°C by which the operational ambient temperature exceeds 40°C.

Note: Requirement for operating in an ambient exceeding 60°C must be referred to the factory.

NB Continuous development of our products entitles us to change specification details without notice, therefore they must not be regarded as binding.

Front cover drawing typical of product range.

WINDING 311

CONTROL SYSTEM	SEPARATELY EXCITED BY P.M.G.							
A.V.R.	MX321	MX341						
VOLTAGE REGULATION	± 0.5 %	± 1.0 %	With 4% ENGINE GOVERNING					
SUSTAINED SHORT CIRCUIT	REFER TO SHORT CIRCUIT DECREMENT CURVES (page 7)							
CONTROL SYSTEM	SELF EXCITED							
A.V.R.	SX460	AS440						
VOLTAGE REGULATION	± 1.0 %	± 1.0 %	With 4% ENGINE GOVERNING					
SUSTAINED SHORT CIRCUIT	SERIES 4 CONTROL DOES NOT SUSTAIN A SHORT CIRCUIT CURRENT							
INSULATION SYSTEM	CLASS H							
PROTECTION	IP23							
RATED POWER FACTOR	0.8							
STATOR WINDING	DOUBLE LAYER CONCENTRIC							
WINDING PITCH	TWO THIRDS							
WINDING LEADS	12							
STATOR WDG. RESISTANCE	0.065 Ohms PER PHASE AT 22°C SERIES STAR CONNECTED							
ROTOR WDG. RESISTANCE	0.83 Ohms at 22°C							
EXCITER STATOR RESISTANCE	20 Ohms at 22°C							
EXCITER ROTOR RESISTANCE	0.078 Ohms PER PHASE AT 22°C							
R.F.I. SUPPRESSION	BS EN 61000-6-2 & BS EN 61000-6-4,VDE 0875G, VDE 0875N. refer to factory for others							
WAVEFORM DISTORTION	NO LOAD < 1.5% NON-DISTORTING BALANCED LINEAR LOAD < 5.0%							
MAXIMUM OVERSPEED	2250 Rev/Min							
BEARING DRIVE END	BALL. 6312-2RS (ISO)							
BEARING NON-DRIVE END	BALL. 6309-2RS (ISO)							
	1 BEARING				2 BEARING			
WEIGHT COMP. GENERATOR	337 kg				350 kg			
WEIGHT WOUND STATOR	120 kg				120 kg			
WEIGHT WOUND ROTOR	110.69 kg				102.32 kg			
WR ² INERTIA	0.6071 kgm ²				0.5754 kgm ²			
SHIPPING WEIGHTS in a crate	360 kg				371 kg			
PACKING CRATE SIZE	105 x 57 x 96(cm)				105 x 57 x 96(cm)			
	50 Hz				60 Hz			
TELEPHONE INTERFERENCE	THF<2%				TIF<50			
COOLING AIR	0.216 m ³ /sec 458 cfm				0.281 m ³ /sec 595 cfm			
VOLTAGE SERIES STAR	380/220	400/231	415/240	440/254	416/240	440/254	460/266	480/277
VOLTAGE PARALLEL STAR	190/110	200/115	208/120	220/127	208/120	220/127	230/133	240/138
VOLTAGE SERIES DELTA	220/110	230/115	240/120	254/127	240/120	254/127	266/133	277/138
KVA BASE RATING FOR REACTANCE VALUES	72.5	72.5	72.5	55	83.8	87.5	87.5	93.8
X _d DIR. AXIS SYNCHRONOUS	2.29	2.07	1.92	1.30	2.52	2.35	2.15	2.12
X' _d DIR. AXIS TRANSIENT	0.18	0.16	0.15	0.10	0.21	0.20	0.18	0.18
X'' _d DIR. AXIS SUBTRANSIENT	0.12	0.11	0.10	0.07	0.14	0.13	0.12	0.12
X _q QUAD. AXIS REACTANCE	1.05	0.95	0.88	0.59	1.16	1.08	0.99	0.98
X'' _q QUAD. AXIS SUBTRANSIENT	0.16	0.14	0.13	0.09	0.13	0.12	0.11	0.11
X _L LEAKAGE REACTANCE	0.07	0.06	0.06	0.04	0.08	0.07	0.07	0.07
X ₂ NEGATIVE SEQUENCE	0.14	0.13	0.12	0.08	0.13	0.12	0.11	0.11
X ₀ ZERO SEQUENCE	0.11	0.10	0.09	0.06	0.10	0.09	0.09	0.08
REACTANCES ARE SATURATED				VALUES ARE PER UNIT AT RATING AND VOLTAGE INDICATED				
T' _d TRANSIENT TIME CONST.	0.03 s							
T'' _d SUB-TRANSTIME CONST.	0.008 s							
T' _{do} O.C. FIELD TIME CONST.	0.75 s							
T _a ARMATURE TIME CONST.	0.0065 s							
SHORT CIRCUIT RATIO	1/X _d							

**60
Hz**

UCI224F
Winding 311

STAMFORD

THREE PHASE EFFICIENCY CURVES

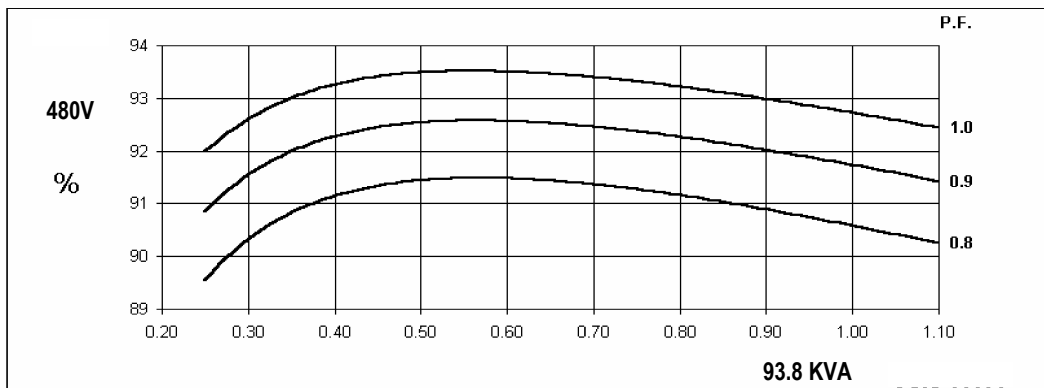
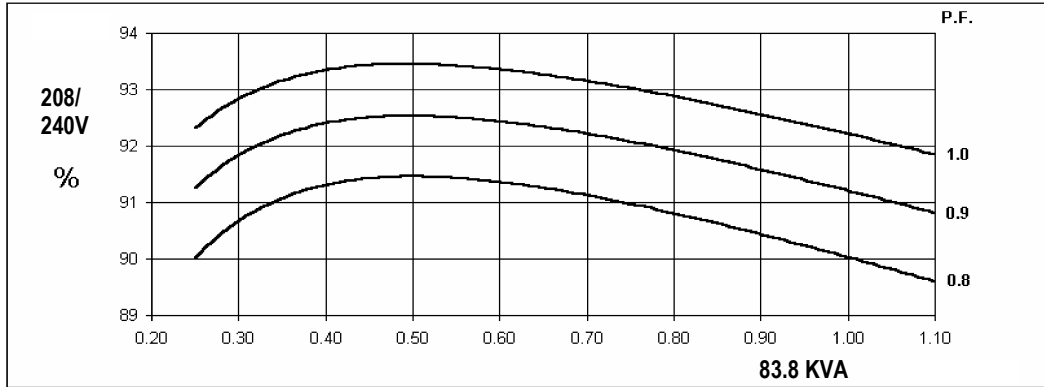

Locked Rotor Motor Starting Curve

MX

**60
Hz**

SX

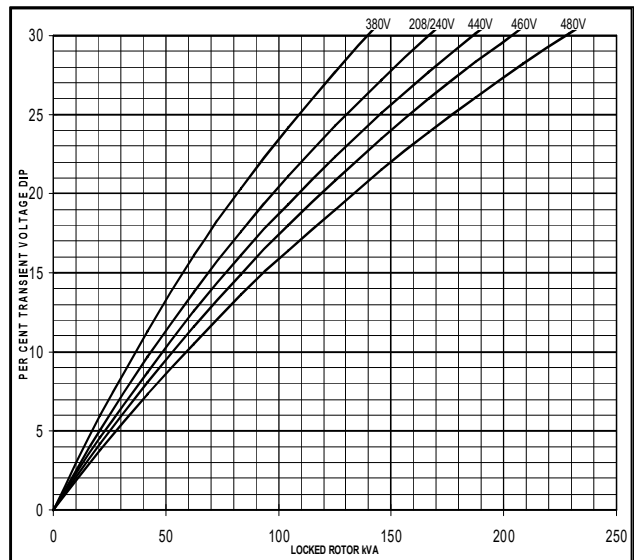
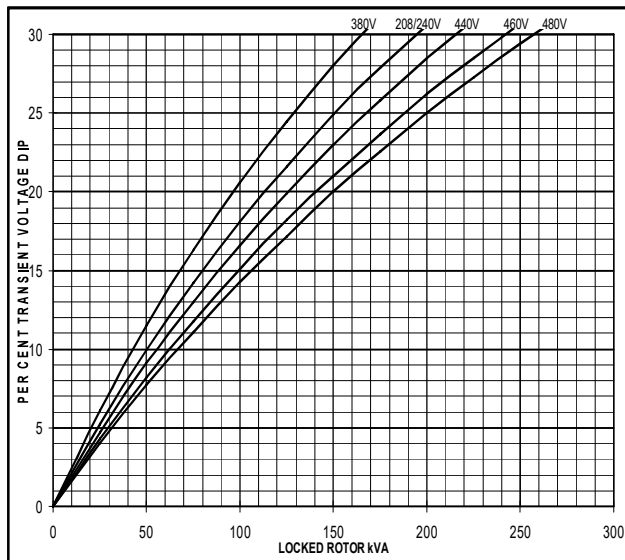

Three-phase Short Circuit Decrement Curve. No-load Excitation at Rated Speed
Based on star (wye) connection.

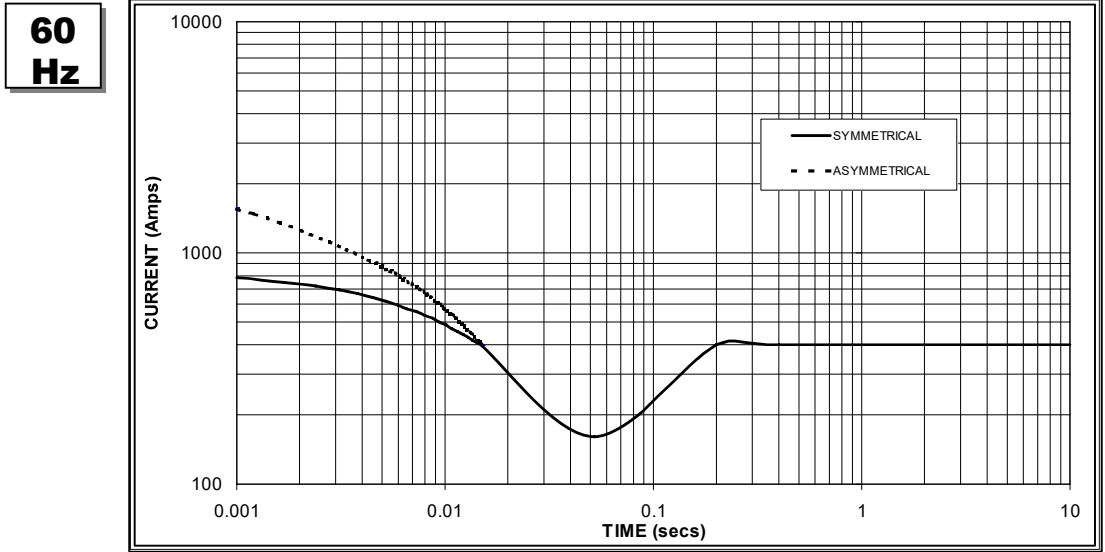

Sustained Short Circuit = 400 Amps

Note 1

The following multiplication factors should be used to adjust the values from curve between time 0.001 seconds and the minimum current point in respect of nominal operating voltage :

50Hz		60Hz	
Voltage	Factor	Voltage	Factor
380v	X 1.00	416v	X 1.00
400v	X 1.07	440v	X 1.06
415v	X 1.12	460v	X 1.12
440v	X 1.18	480v	X 1.17

The sustained current value is constant irrespective of voltage level

Note 2

The following multiplication factor should be used to convert the values calculated in accordance with NOTE 1 to those applicable to the various types of short circuit :

	3-phase	2-phase L-L	1-phase L-N
Instantaneous	x 1.00	x 0.87	x 1.30
Minimum	x 1.00	x 1.80	x 3.20
Sustained	x 1.00	x 1.50	x 2.50
Max. sustained duration	10 sec.	5 sec.	2 sec.

All other times are unchanged

Note 3

Curves are drawn for Star (Wye) connected machines. For other connection the following multipliers should be applied to current values as shown :

Parallel Star = Curve current value X 2

Series Delta = Curve current value X 1.732

RATINGS

Class - Temp Rise		Cont. F - 105/40°C				Cont. H - 125/40°C				Standby - 150/40°C				Standby - 163/27°C			
60 Hz	Series Star (V)	416	440	460	480	416	440	460	480	416	440	460	480	416	440	460	480
	Parallel Star (V)	208	220	230	240	208	220	230	240	208	220	230	240	208	220	230	240
	Delta (V)	240	254	266	277	240	254	266	277	240	254	266	277	240	254	266	277
	kVA	75.0	78.1	78.1	82.5	83.8	87.5	87.5	93.8	88.8	92.5	92.5	100.0	91.9	95.0	95.0	102.5
	kW	60.0	62.5	62.5	66.0	67.0	70.0	70.0	75.0	71.0	74.0	74.0	80.0	73.5	76.0	76.0	82.0
	Efficiency (%)	90.5	90.7	90.9	91.0	90.0	90.3	90.6	90.6	89.8	90.1	90.4	90.4	89.6	89.9	90.3	90.3
kW Input	66.3	68.9	68.7	72.5	74.5	77.5	77.3	82.8	79.1	82.1	81.9	88.5	82.1	84.5	84.2	90.8	

MX321 Voltage Regulator



MX321 is a three phase sensed Automatic Voltage Regulator and forms part of the excitation system for a brush-less generator. Excitation power is derived from a three-phase permanent magnet generator (PMG), to isolate the AVR control circuits from the effects of nonlinear loads and to reduce radio frequency interference on the generator terminals. Sustained generator short circuit current is another feature of the PMG system.

Voltage Adjustment

The screwdriver adjustable potentiometer adjusts the generator output voltage. Adjustment clockwise increases the generator output voltage.

When using a remote voltage adjust rheostat, remove the jumper wire across terminals 1 and 2 and install a 1k ohm 1 watt rheostat. This will give $\pm 10\%$ voltage variation from the nominal.

Stability Adjustment

The AVR includes a stability or damping circuit to provide good steady state and transient performance of the generator.

A jumper link selector is provided to optimize the response of the stability circuit to various size generators. The link should be positioned as shown in the diagram according to the kW rating of the generator.

The correct setting of the Stability adjustment can be found by running the generator at no load and slowly turning the stability control anti-clockwise until the generator voltage starts to become unstable.

The optimum or critically damped position is slightly clockwise from this point (i.e. where the machine volts are stable but close to the unstable region).

Under Frequency Roll Off (UFRO) Adjustment

The AVR incorporates an underspeed protection circuit which gives a volts/Hz characteristic when the generator speed falls below a presettable threshold known as the "knee" point.

The red Light Emitting Diode (LED) gives indication that the UFRO circuit is operating.

The UFRO adjustment is preset and sealed and only requires the selection of 50 or 60Hz and 4 pole or 6 pole, using the jumper link as shown in the diagram.

For optimum setting, the LED should illuminate as the frequency falls just below nominal, i.e. 47Hz on a 50Hz system or 57Hz on a 60Hz system.

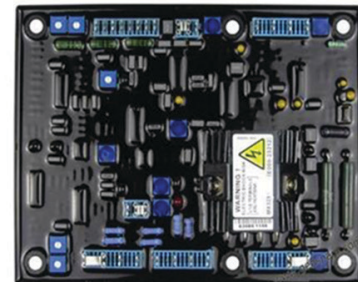

Specifications

Sensing Input

Voltage	190 to 264VAC max, 1 or 3 phase
Frequency	50 to 60 Hz Nominal

Power Input (PMG)

Voltage	170 to 220VAC, 3 phase
Current	3A
Frequency	100 to 120 Hz Nominal

Output

Voltage	max 120VDC
Current	Continuous 3.7A Intermittent 6A for 10 secs
Resistance	15 ohms Minimum

Regulation $\pm 0.5\%$ RMS

Thermal Drift 0.02% per 1°C change in AVR ambient

Soft Start Ramp Time 0.4 - 4 seconds

Typical System Response

AVR Response	10 ms
Field Current to 90%	80 ms
Machine Volts to 97%	300 ms

External Voltage Adjustment $\pm 10\%$ with 1k ohm 1 watt trimmer

Under Frequency Protection

Set Point	95% Hz
Slope	100 to 300% down to 30 Hz
Max. Dwell	20% volts/S Recovery

Unit Power Dissipation 18 watts Maximum

Analog Input

Maximum Input	± 5 VDC
Sensitivity	1V for 5% Generator Volts (Adjustable)
Input Resistance	1k ohm

Quadrature Droop Input 10 ohms Burden

Max. Sensitivity	0.22A for 5% Droop 0PF
Max. Input:	0.33A

Current Limit Input 10 ohms burden

Sensitivity Range	0.5 to 1A
-------------------	-----------

Over Voltage Detection Input 10 ohms Burden

Set Point	300V Time Delay: 1 sec (Fixed)
CB Trip Coil Volts	10 to 30VDC
CB Trip Coil Resistance	20 to 60 ohms
Time Delay	1 second (Fixed)

Over Excitation Protection

Set Point	75VDC
Time Delay	8 to 15 seconds (Fixed)

DCP7310 Controller



The DCP7310 is an Auto Start Control Module suitable for a wide variety of single, diesel or gas, gen-set applications. The 7310 provides gen-set control, transfer switch control, metering, monitoring & protection.

Key Benefits

- ▶ Real-time clock provides accurate event logging
- ▶ Multiple date and time scheduler
- ▶ Set maintenance periods can be configured to maintain engine performance
- ▶ Can be integrated into building management systems (BMS) using MODBUS
- ▶ Increased input and output expansion capability via DSENet®
- ▶ Licence-free PC software
- ▶ IP65 rating (with supplied gasket) offers increased resistance to water ingress
- ▶ PLC functionality
- ▶ Data logging to assist with fault finding and diagnosis
- ▶ cULus Listed



Advanced Features

- ▶ 4-Line back-lit LCD text display
- ▶ Five key menu navigation
- ▶ Front panel editing with PIN protection
- ▶ Customizable status screens
- ▶ Power save mode
- ▶ 8 Configurable inputs
- ▶ 6 Configurable DC outputs
- ▶ 2 configurable volt-free relay outputs
- ▶ Flexible sensor inputs
- ▶ Configurable timers and alarms
- ▶ 3 configurable maintenance alarms
- ▶ Multiple date and time scheduler
- ▶ Configurable event log (250 events)
- ▶ CAN engine support through FT4
- ▶ Integral PLC editor
- ▶ Easy access diagnostic page
- ▶ CAN and Magnetic Pick-up/Alt. inputs
- ▶ Fuel usage monitor and low fuel alarms
- ▶ Charge alternator failure alarm
- ▶ Load monitoring (kW, frequency, voltage)
- ▶ Support for 0V to 10V & 4mA to 20mA sensors
- ▶ LED and LCD alarm indication
- ▶ Power monitoring (kWh, kVAR, kVAh, kVArh)
- ▶ Load switching (load shedding and dummy load outputs)
- ▶ Unbalanced load protection
- ▶ USB connectivity
- ▶ Backed up real time clock
- ▶ Fully configurable via DSE Configuration Suite PC software
- ▶ Remote SCADA monitoring via DSE Configuration Suite PC software
- ▶ User selectable simultaneous RS232, RS485
- ▶ Configurable MODBUS pages
- ▶ MODBUS RTU & TCP support
- ▶ Advanced SMS messaging (additional external modem required)
- ▶ Additional display screens to enhance with modem diagnostics
- ▶ Idle control for starting
- ▶ DSENet® expansion compatible

Specifications

DC Supply	
Continuous Voltage Rating	8V to 35V Continuous
Cranking Dropouts: Able to survive 0V for 100mS, providing supply was at least 10V before dropout and supply recovers to 5V. This is achieved without the need for internal batteries.	
Maximum Operating Current	510mA at 12V, 240mA at 24V
Maximum Standby Current	330mA at 12V, 160mA at 24V
Charge Fail/Excitation Range	0V to 35V
Outputs	
Output A (Fuel)	15ADC at Supply Voltage
Output B (Start)	15ADC at Supply Voltage
Outputs C & D (Volt free)	8A at 250VAC
Aux Outputs E to J	2ADC at Supply Voltage
Generator	
Voltage Range (L-L)	26V to 719VAC
Voltage Range (L-N)	15V to 415VAC
Frequency Range	3.5 Hz to 75 Hz
Bus	
Voltage Range	15V to 415VAC (L-N)
Frequency Range	3.5 Hz to 75 Hz
Magnetic Pickup	
Voltage Range	+/- 0.5V to 70V
Frequency Range	10,000 Hz (max)
Display	
LCD Heated Display	-40°F to 158°F

Front Panel LED Indicators:

- ▶ Manual: Indicates controller is in the MANUAL mode
- ▶ Stop: Indicates controller is in the STOP mode
- ▶ Auto: Indicates unit is in the AUTO mode
- ▶ Generator Available: Indicates when the generator is available to take load
- ▶ Generator Breaker: Indicates system is supplying current to a connected load
- ▶ Four Configurable Status LEDs: Configurable via DSE Configuration Suite PC software

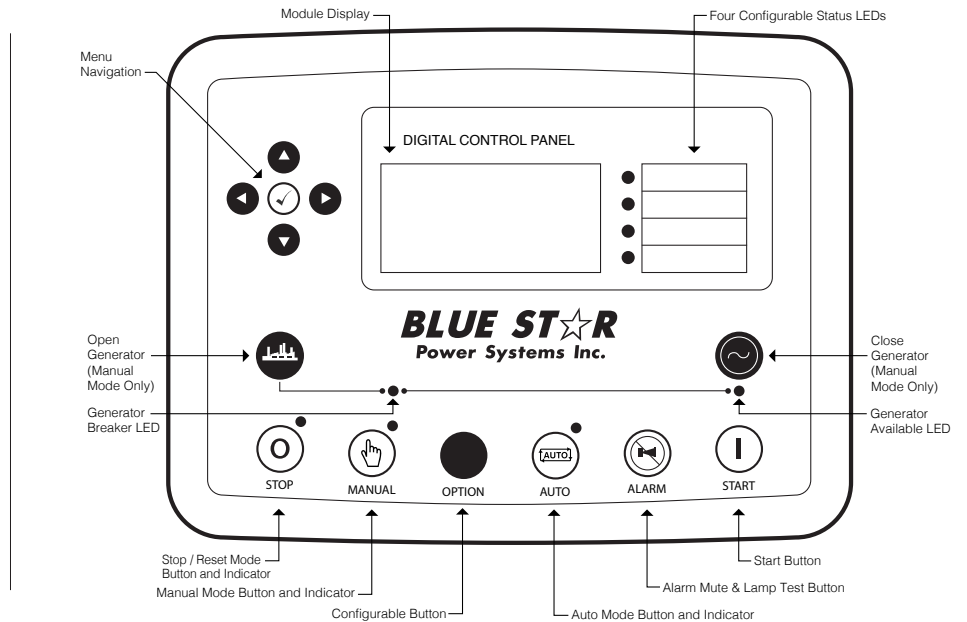

Standard Engine Protection Functions

Pre-Alarms (Warnings)

- ▶ Low Oil Pressure
- ▶ High Coolant Temperature
- ▶ Low Coolant Temperature
- ▶ Battery Overcharge (High Voltage)
- ▶ Weak Battery (Low Voltage)
- ▶ Low Load

- ▶ Def Level
- ▶ Battery Charger Failure
- ▶ Engine Sender Unit Failure
- ▶ Engine kWe Overload
- ▶ Maintenance Interval Timer
- ▶ Low Fuel Level
- ▶ Fuel Leak Detect

Alarms (Shutdowns)

- ▶ Low Oil Pressure
- ▶ High Coolant Temperature
- ▶ Overspeed
- ▶ Overcrank
- ▶ Fuel Sender Failure
- ▶ Def Level

All alarms and pre-alarms can be configured via the DSE Configuration Suite PC software or the front panel.

Optional Features

- ▶ Generator Protection - 27(2), 32, 40Q, 51(2), 59(2), 81O, 81U
- ▶ Enhanced Generator Protection - 51 and 47
- ▶ Selection of Integrating Reset or Instantaneous Reset Characteristics for Overcurrent Protection
- ▶ Ethernet and 4G (GSM) remote monitoring and communications via DSE WebNet Software
- ▶ Automatic Transfer Switch Control
- ▶ Remote Emergency Stop
- ▶ Multilingual Capability
- ▶ High Fuel Level Pre-Alarm
- ▶ Critical Low Fuel Level Alarm
- ▶ Analog Meters

Generator Protection

- ▶ Undervoltage (27)
- ▶ Overvoltage (59)
- ▶ Underfrequency (81U)
- ▶ Overfrequency (81O)
- ▶ Overcurrent (51)
- ▶ Reverse Power (32)
- ▶ Loss of Excitation (400)
- ▶ Phase Imbalance (47)

All generator protection features are programmable as alarms or pre-alarms.

DRP2510 Remote Display Panel

The DRP2510 is a display module designed to work with the DCP7310 Auto Start. Up to three display modules can be connected to one host control module, and can be positioned up to a maximum distance of 3,280 (1km) away. All remote displays connected to the same system, will show the same information at any one time, while the host controller is able to display different information. The modules are simple to operate, and feature the same user-friendly, menu layout as the host module. All communications and configuration are done via the host module only. The remote devices simply mirror the configuration of the host module, making the system quick and easy to install.

DSE2548 DSENET® Output Expansion Module

The DSE2548 is an LED expansion module that can be used with all DSENet® compatible control modules. The module has been designed to display a maximum of height individual LED indications up to a maximum distance of 3,280 (1km). The DSE2548 is presented in a vertical enclosure. It includes an alarm sounder that is triggered when the host controller detects an alarm condition. The alarm can be muted directly from the DSE2548 using the front push button. The DSE2548 includes individual LEDs for each channel and a 'Power On' LED that flashes when the link with the host controller is lost.

DSE890 MKII DSEWebNet® Gateway 4G (GSM/Ethernet) Remote Communications Interface

The DSE890 MKII 4G gateway is used in conjunction with supported DSE controllers to provide remote monitoring and communications data via the DSEWebNet® software. The DSE890 MKII gateway communicates with a maximum of five connected DSE controllers, monitoring their instrumentation and operating states. The DSEWebNet® software is accessed using an internet browser or mobile app connection. Users are able to perform multiple tasks including: monitoring equipment, clearing alarm conditions and starting/stopping equipment at the click of a button.

DSE2548 DSENET® Output Expansion Module

The DSE2157 is an output relay expansion module for use with DSENet® compatible control modules. The DSE2157 has been designed to extend a host module's output capabilities. A maximum of 10 DSE2157's can be connected to an individual module at any one time. All outputs are configurable via the host controller. The additional output capabilities of the DSE2157 give OEMs the flexibility to meet increasingly complex industry specifications.

DSE2130 DSENET® Input Expansion Module

The DSE2130 is an input expansion module for use with DSENet® compatible control modules. The additional input capabilities of the DSE2130 give OEMs the flexibility to meet increasingly complex industry specifications. The DSE2130 provides an additional eight digital inputs, with four of these configurable for use as analog inputs. All inputs are configured within the host controller.

DSE2133 DSENET® RTD / Thermocouple Input Expansion Module

The DSE2133 Input Expansion Module is used in conjunction with supported DSENet controllers to provide 8 additional configurable inputs. Up to four modules can be linked together to provide up to 32 additional inputs. The inputs can be configured as RTD or Thermocouple inputs in the 'host controller'.

DSE2131 Ratiometric Input Expansion Module

The DSE2131 Ratiometric Input Expansion module is used in conjunction with supported DSENet controllers to provide additional, flexible, input functionality. The ratiometric inputs can be configured in a number of ways to connect to digital switches, resistive sensors, 0 to 10VDC signals or 4 to 20 mA signals.

DSE2152 Analog Output Expansion Module

The DSE2152 Analog Output Expansion Module is used in conjunction with supported DSENet controllers to provide 6 additional outputs. The outputs can be individually configured as 0 to 10V or 4 to 20mA, via the "host controller". Up to four DSE2152 modules can be linked together to provide up to 24 additional outputs. An ID switch is provided on the module for identification.

DSE2548 Remote Annunciator



The DSE2548 is a powerful remote display to match Blue Star Power Systems, Inc. DCP7310 control panel. It may be powered from the engine starting batteries at 12V, 24VDC, or AC to DC converter. The DSE2548 uses DSENET communications between itself and the DCP to reduce the number of wires required to activate all the alarms. The DSENET communications can be used on remote displays up to 3,280 (1km) feet away from the DCP. The DSE2548 has 9 LEDs per annunciator for a total of 18 LEDs to indicate Alarms, Pre-Alarms and operating conditions of the emergency standby generator system. The DSE2548 also comes complete with a box for easy installation. The DSE2548 is available in two mounting configurations: surface and semi-flush mount. These panels comply with the requirements of NFPA 110.



Key Benefits

- Annunciation of 16 alarms and pre-alarms as detected by the DCP
- Annunciation of 2 status indicators
- Audible alarm horn
- Lamp Test and Alarm Silence switches
- Power supply inputs for 12V or 24VDC
- DSENET communications
- Two mounting configurations
- Box included
- Designed for use in harsh environments
- Works up to 3,280 (1km) from the host controller
- 10 modules can be linked together to one host controller
- Eight configurable LEDs

ID Switch

The rotary ID switch is used to select the address of the DSE2548 expansion module, as the host control module is capable of giving instructions to a number of DSE2548 expansion modules at the same time.

Operating Range

- Up to 3280 ft. from the DCP7310
- Recommended Wire - Belden 9841

Specifications

DC Supply

Continuous Voltage Rating 8V to 35V Continuous

Cranking Dropouts:
Able to survive 0V for 50mS, providing supply was at least 10V before dropout and supply recovers to 5V. This is achieved without the need for internal batteries. LEDs and backlight will not be maintained during cranking.

Maximum Operating Current 112mA at 12V, 53mA at 24V

Maximum Standby Current 74mA at 12V, 35mA at 24V

Dimensions

Overall 14"W x 10"H x 5.45"D
355.6 mm x 254 mm x 138.4 mm

Panel Cut-Out 12.50"L x 8.50"H
317.5 mm x 215.9 mm

Panel Thickness 1.45"
36.8 mm

Environmental Testing Standards

Electro-Magnetic Compatibility

BS EN 61000-6-2	EMC Generic Immunity Standard for the Industrial Environment
BS EN 61000-6-4	EMC Generic Emission Standard for the Industrial Environment

Electrical Safety

BS EN 60950	Safety of Information Technology Equipment, including Electrical Business Equipment
-------------	---

Temperature

BS EN 60068-2-1	Ab/Ae Cold Test -30°C
BS EN 60068-2-2	Bb/Be Dry Heat +70°C

Vibration

BS EN 60068-2-6	Ten sweeps in each of three major axes 5 Hz to 8 Hz @ +/-7.5mm, 8 Hz to 500 Hz @ 2 gn
-----------------	--

Humidity

BS EN 60068-2-30	Db Damp Heat Cyclic 20/55°C @ 95% RH 48 Hours
BS EN 60068-2-78	Cab Damp Heat Static 40°C @ 93% RH 48 Hours

Shock

BS EN 60068-2-27	Three shocks in each of three major axes 15 gn in 11 mS
------------------	---

Degrees of Protection Provided by Enclosures

BS EN 60529	IP65 - Front of module when installed into the control panel with the supplied sealing gasket.
-------------	--

Generator Set

Blue Star Power Systems, Inc. completely paints all of its generator sets in our state-of-the-art downdraft paint booth. It begins with an extensive cleaning of the unit through sanding and a full wipe down using an alkaline-based cleaner. Once completely clean, the unit is then painted with Cardinal Industrial Semigloss paint. Electrostatic paint equipment ensures correct and even coverage. The unit then receives a complete covering of Cardinal Industrial Clear Coat in a hammer texture to provide extra protection and a durable long-lasting easy-to-clean finish.

Performance Characteristics

- 3.0+ Mils TDFT
- Xenon Arc 1100 hours - Excellent Weatherability
- 1000 Hour Salt Spray - Over Primer - Passed (3.0 Mils Total TDFT)
- Adhesion, Crosshatch - 5B
- Gloss 90+ @ 60°

Generator Set Enclosure

Blue Star Power Systems, Inc. provides Cardinal Industrial Hammer Textured Semi-Gloss Polyester Powder Coating as standard on all our enclosures. Long term exterior durability, high performance mechanical properties and high gloss are standard characteristics of Cardinal Powder Coating. Cardinal TGIC Polyester Coating exceeds UL 2200 & CSA requirements.

Performance Characteristics

- Cured Powder Properties 2.0+ Mils DFT
- PCI Powder Smoothness 1 Mil
- Pencil Hardness 2H+
- Flexibility 1/8 in Diameter - No Fracture
- Salt Spray ASTM-B117 1000 Hours - Pass
- Humidity ASTM-02247 1000 Hours - Pass
- Adhesion, Crosshatch - 5B
- Gloss 90+ @ 60°

Standard Colors

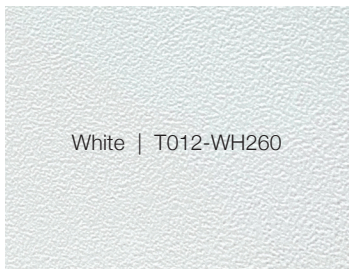

Custom Colors

Custom Colors: Blue Star Power Systems, Inc. offers custom color options for your generator set enclosure. Cardinal is licensed by PANTONE® to accurately simulate both the PANTONE MATCHING SYSTEM® colors and the PANTONE® Textile Color System® with our powder and liquid coatings. Additional Charges apply.



Sub-Base Fuel Tanks

Blue Star Power Systems, Inc. provides either Diamond Vogel Nexgen Technology Paint or Cardinal Industrial Hammer Textured Semi-Gloss Polyester Powder Coat on all of our sub-base fuel tanks. Nexgen and Cardinal Industrial both offer excellent coverage and performance characteristics. Nexgen and Cardinal Industrial both exceed UL requirements.

Performance Characteristics

- 3.0+ Mils TDFT
- Xenon Arc 1100 Hours
- 500 Hour Salt Spray - Over Primer - Passed (3.0 Mils Total TDFT)
- Adhesion Crosshatch - 5B
- Gloss 90+ @ 60°

Standard Color



Blue Star Power Systems, Inc. enclosures are specifically designed for optimal protection against the elements. They are designed to protect the entire system from even the most extreme environments, and to reduce sound levels to most specified requirements. Blue Star Power Systems, Inc.'s vast flexibility allows the design of standard enclosures to meet most specifications or requirements. All standard enclosure models are constructed of 14 gauge steel and feature a pitched roof for increased structural integrity and superior watershed. All enclosures feature a rugged UL listed hammer powder coat finish as standard for a long lasting and durable finish in standard white or gray. Custom colors are available as specified.

Enclosure Design Features



- UL 2200 & CSA Listed as standard
- All enclosure models are 200 MPH wind rating certified in accordance with IBC2018 and ASCE/SEI 7-16 standards.
- Lockable gasketed doors with draw down latches and Stainless Steel component hinges
- All Stainless Steel fasteners
- UL & CSA listed extreme-wear hammer powder coat finish
- Pitched roof for high structural integrity and superior watershed
- Above-door drip guards
- Optimal airflow means no cooling system de-rates on most models
- Internally mounted exhaust silencers standard up to 600 kW
- Sound attenuation options
- Stainless Steel and Aluminum enclosure options

Level 1

Weather Proof Enclosure

Blue Star Power Systems, Inc. Level 1 enclosures have the rugged construction and weather proof protection required for most outdoor environments. These enclosures will effectively protect the gen-set through high wind (200 MPH), rain, snow, and other extreme weather conditions. Weather proof enclosures feature standard hinged lockable doors, a pitched roof to prevent water accumulation and improved structural integrity. The enclosure is painted with extreme-wear UL and CSA listed hammer powder coat finish.

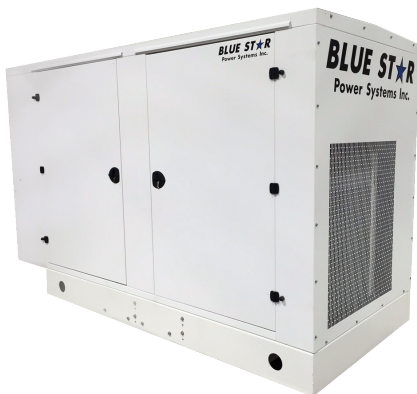

Level 2

Weather Proof Enclosure with Foam

Blue Star Power Systems, Inc. Level 2 enclosures include all of the same great features of the Level 1 enclosures, and include even more. With the addition of high performance 1.5" Type D Sound Attenuating Foam, our Level 2 Enclosures offer an even lower dBA rating with the same great weather proof protection.

Level 3

Sound Attenuated Enclosure

Blue Star Power Systems, Inc. Level 3 enclosures feature the same great weather proof protection and standard features as the Level 1 & 2 enclosure models, but with a greater emphasis on reducing sound levels. Standard Level 3 features include the same high performance 1.5" type D sound attenuating foam, and also feature the addition of a separate frontal exhaust sound chamber and dual rear air intake to ensure that your system runs exceptionally quiet. These features make this enclosure among the best in the industry for noise reduction and quality.



Radiators

Blue Star Power Systems, Inc. radiators offer a variety of styles and configurations including radiator and charged air assemblies, radiator and aftercooler assemblies with durable core construction. Our radiators are compact and efficient meeting the most stringent enclosure footprint requirements. All radiators are sized for 50°C (122°F) ambient. The single-source design ensures a perfect match with your generator set package.

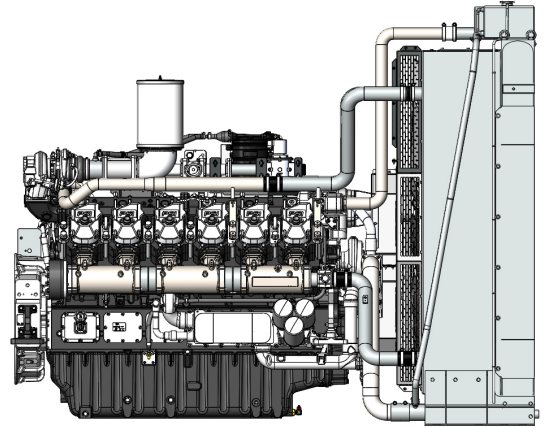

Radiator Features

Standard Radiator Package

- Engine-specific tank design with variant coolant connection locations and sizes (dependant on engine size)
- Complete cooling package with mounting foot and plumbing kit
- All steel construction of top and bottom tanks
- Dual Core designs -
 - Jacket Water / Charged Air Circuit
 - Jacket Water / After Cooler Circuit
- Individual radiators designed to meet manufacturer's specific requirements
- Top tank has built in expansion capacity - no need for an external recover tank
- Full or partial deration system built into the top tank
- Standard cooling package includes fan shroud & fan guard
- Corrosion preventive options:
 - Hot dipped galvanizing on all steel parts or stainless steel
 - Epoxy coated cores

Fan-On Radiator Design

- Engine-specific tank design with variant coolant connection locations and sizes (dependant on engine size)
- Rigid built construction for fan support
- High speed bearings within pillow blocks
- Dual Core designs with variable jacket water / after cooler circuit designs
- All steel construction of top and bottom tanks
- Individual radiators designed to meet manufacturer's specific requirements

Circuit Breakers



Blue Star Power Systems, Inc. MC (Molded Case) Series Circuit Breakers are the highest quality in the industry. They will protect the power system and corresponding equipment from damaging fault currents circuits and overloads.

80% Rated Circuit Breakers

80% rated breakers can only be applied continuously at 80% of the rated breaker. Tripping of the circuit breaker if the current goes above 80% will depend on the amount of current and the duration.

100% Rated Circuit Breakers

100% rated breakers can be applied at 100% of their current rating continuously.

Accessories

Shunt Trip - Provides a means of tripping the circuit breaker from a remote source by energizing a solenoid in the breaker. This can be achieved through the panel faults such as engine shutdowns, overcurrent, etc. The circuit breaker will have to be reset locally in the event of a tripped breaker.

Bell Alarm / Alarm Switch - Provides remote indication of whether the circuit breaker is in a tripped position. The bell alarm will remain unchanged during on-off operations and during operation by the Push-to-Trip button on the circuit breaker.

Auxiliary Switch/Contacts - Provides remote indication of whether the circuit breaker is in an open or closed state.

Ground Fault Indication/Alarm - Adjustable relay that indicates a ground fault condition with adjustable time delay.

Trip Unit

LI Breakers - Includes adjustable Long-Time pickup and delay and adjustable Instantaneous pickup.

LSI Breakers - Includes features of LI Breakers with addition of Short-Time pickup and delay.



Breaker Model	Amperage	Percentage Rated	Maximum Voltage Rating (AC)	UL Listed Interrupting Rating (kA)			Lug Qty. and Size (Cu & Al)
				240	480	600	
H-Frame	15-150	80% or 100%	600	25	18	14	(1) #14-3/0
Q-Frame	70-250	80%	240	10	-	-	(1) #4-300 kcmil
J-Frame	150-175	80% or 100%	600	25	18	14	(1) #4-4/0
	200-250						(1) 3/0-350 kcmil
L-Frame	125-400	80% or 100%	600	65	35	18	(2) 2/0-500 kcmil
	200-600	80%	600				
M-Frame	300-800	80%	600	65	35	18	(3) 3/0-500 kcmil

Breaker Model	Frame Size	Percentage Rated	Maximum Voltage Rating (AC)	UL Listed Interrupting Rating (kA)			Lug Qty. and Size (Cu & Al)
				240	480	600	
P-Frame	600	80% or 100%	600	65	35	18	(3) 3/0-500 kcmil
	800						(4) 3/0-500 kcmil
	1000						(12) 3/0-750 kcmil
	1200						(15) 3/0-750 kcmil
R-Frame (LSI Standard)	1600	100%	600	65	35	18	(18) 3/0-750 kcmil
	2000						(21) 3/0-750 kcmil
	2500						
	3000						

TPS Series Block Heaters



The TPS engine block heater is designed to preheat diesel and gaseous engines. It is simple to install, lightweight, and heats engines up to 12L displacement. Thermosiphon circulation of the coolant delivers even heat throughout the entire engine block.

Features

- cULus Listed
- CE Compliant
- Various temperature settings available, including an optional adjustable thermostat 90° - 130°F (32° - 54°C)
- Can be supplied with UL marked 120 or 240V NEMA plug



Specifications

Part Number	Volts	Watts	Amps	Male Plug	Outlet Size (Inches)
13224	120	500	4.2	Yes	5/8
14209	240	500	2.1	Yes	5/8
10014	120	1000	8.4	Yes	5/8
10015	240	1000	4.2	Yes	5/8
10016	120	1500	12.5	Yes	5/8
10017	240	1500	6.3	Yes	5/8
10018	120	1800	15	Yes	5/8
10019	240	2000	8.3	Yes	5/8

Single Stage Air Cleaner



Single Stage Air Cleaners are tough, non-metallic, lightweight, self-supporting and completely disposable. They are also easy to install, durable, and reliable. They are designed to function well under high and severe pulsation conditions found in many applications. Vibration-resistant media is potted into molded housings of rugged ABS plastic – so they don't fall apart as other designs might. They can be mounted vertically or horizontally.



Specifications

- No serviceable parts - Air cleaner housing and filter are one unit
- Designed to withstand severe intake pulsation
- Economical replacement cost
- Self-supporting, sturdy
- Very reliable: only one critical seal
- Lightweight and compact in size
- Non-metallic, non-corrosive
- Completely disposable - acceptable for normal trash pick-up (should not be incinerated)
- Easily installed and maintained
- Minimal removal clearance needed: only 1.5"
- Three airflow styles available to fit virtually any engine intake configuration
- Various media available for specific generator set applications: high pulsation, high humidity, etc.
- Temperature tolerance: 180°F/83°C continuous 220°F/105°C intermittent

CPJ Series Critical Grade Silencers



Blue Star Power Systems, Inc. "CPJ" Series is the accumulation of research and development offering a compact silencer without compromising performance. It incorporates a unique combination of resonator chambers, acoustically packed internal components and diffusers to achieve a stunning level of performance for its size. All CPJ series silencers are critical grade silencers and are packed with insulation to greatly reduce radiated noise and exterior shell temperature.

Standard Construction Features

- Available in sizes from 2 inch to 12 inch
- Multitude of inlet/outlet design styles to meet almost any requirement
- Packed with fiberglass insulation to reduce shell temperature and noise levels
- Fully welded double shell carbon steel weldment construction, corrosive resistant
- High density fiberglass acoustic blanket good to 1500°F, wrapped with 304 Stainless Steel wire mesh cloth and encased in a carbon steel perforated facing
- Black phenolic resin based finish paint



Optional Construction Features and Accessories

- Stainless Steel construction
- Aluminum construction
- Aluminized Steel construction
- Vertical mounting legs
- Round mounting bands
- Horizontal mounting saddles
- Horizontal and vertical shell lugs
- Special finish per specification
- Air leak test
- ASME code construction
- Oversized flanges
- Acoustic shell lagging
- High temperature acoustic pack material
- Contact factory for additional features to meet your requirements

Model #	Part #	Outlet Size	Flanged Connection	WT (lbs)
CPJS-02	10660	2.0" OD	No	12
CPJS-25	10661	2.5" OD	No	18
CPJS-03	10662	3.0" OD	No	20
CPJS-35	10663	3.5" OD	No	30
CPJS-04	10664	4.0" OD	No	31
CPJS-05	10665	5.0" OD	No	50
CPJS-06	10666	6.0" OD	Yes	50
CPJS-08	10667	8.0" OD	Yes	120
CPJS-10	10668	10.0" OD	Yes	180

Engine Starting Batteries

Blistering heat and bitter cold are ruthless battery killers. That's why Blue Star Power Systems, Inc. utilizes a pioneered climatized battery. Designed to offer you long-life and high-performance starting power that will get your gen-set running even under extreme conditions. Blue Star Power Systems, Inc. "all-climate" batteries stand up to the harshest temperatures and are available in sizes and configurations to fit almost any application.



Standard Features

- Unique Manifold Vent - Virtually eliminates corrosion by venting gases away from terminals and cables
- Exclusive TRP™ Construction – Rib reinforced TRP™ container significantly improves the vibration and impact resistance
- Armored Plate Cell Bonding - Vibration is the number one killer of commercial batteries. To solve this problem, the cells of every battery are bonded
- Polyethylene Enveloped Separator Design – Super tough polyethylene material reduces electrical resistance and provides higher cranking performance
- Center Lug Design - Suppresses the vibration inherent in traditional construction for improved performance (where applicable)
- TTP™ - Through-the-Partition inter-cell connectors create a shorter current path to deliver more power to the terminals
- Heavy Duty Cases - Reinforced polyethylene or hard rubber cases stand up to the demands of standby gen-sets
- Convenient Lifting Slots - a handle is built in the top of the battery for easy carrying and transportation
- Protective Bottom Design - Waffled bottom design provides protection against nuts, bolts, or stones that might become lodged under the battery
- Computer Designed Radical Grids - An improved state-of-the-art design which adds power and resists vibration
- Threaded Accessory Ports - Features a sealed "O" ring that does not work loose during severe service (78DT only)

Specifications

BCI Group Size	NEMA Type			Dimensions (Inches)			
	Part Number	CCA at 0°F	CCA at 32°F	Length	Width	Height	Weight (lbs.)
78DT	78DT-HD	800	960	10-11/16	7-1/16	8-1/8	54
4D	4D-HD	1000	1200	19-9/16	8-5/16	10	95
8D	8D-HD	1300	1560	20-3/4	11	10	117

Deep Sea Battery Charger



The DSEBC2410Ei is an enclosed intelligent battery charger designed to work with multiple battery types across a wide range of applications.

The advanced technology has been developed to automatically detect system settings and charging profiles including cell voltage and boost voltage to provide high-levels of charging support.

A comprehensive range of input and output protections ensure a continued safe charging environment also enabling the use of the charger as a power supply.

Key Benefits

- Fully flexible to maximize the life of the battery
- Suitable for a wide range of battery types
- NFPA110 Compliant
- Fault output
- Maximum 91% operating efficiency
- No external intervention for boost mode
- Multiple chargers can be linked together to provide larger current output
- Can be permanently connected to battery and utility supply. No need to disconnect through high load conditions.
- cULus Listed



Advanced Features

- Intelligent two, three and four stage charging profiles
- 12V / 24V auto voltage detection for multiple battery types
- Adjustable current limit
- Can be used as a battery charger, power supply or both at the same time
- Automatic or Manual boost and storage charge functions to help maintain battery condition
- Digital Microprocessor Technology
- Temperature compensation for battery charging
- Low Output Ripple and superb line regulation
- Available in two variants (LCD display or LCD display & analog meters)
- Full Protection
- AC input Under voltage | AC input Over voltage
- Battery charger output Over voltage | Battery charger output Over current
- Battery temperature compensation with over temperature protection
- Output short circuit and inverse polarity protection with auto recovery
- Automatic power de-rating at high ambient temperatures
- Battery charger failure indication
- Automatic Boost Mode boosts and equalizes cell charge improving battery performance and life
- Power Save Mode
- Once the battery is fully charged the chargers switch to Eco-Power to save energy consumption
- Can be integrated into external systems through MODBUS RTU using RS485
- Fully configurable via DSE Configuration Suite PC Software
- DSE2541 External remote display option

Specifications

AC Supply

Voltage Range	90V to 305V (L-N)
Frequency Range	48 Hz to 64 Hz (L-N)

DC Output Rating

Output	10ADC at 12V & 24VDC
Ripple and Noise	<1%
Efficiency	>86%
Auxiliary Output	100mA at 12VDC

Regulation

Line	<0.5%
Load	2%

Temperature Sensor Input - PT1000

Protections

Short Circuit	DC Over and Under Voltage
DC Over Current	Reverse Polarity
Over Temperature	AC Under & Over Voltage
Battery Charger Failure	

Charge Failure Relay - 3A at 30VDC Volt Free Relay

Temperature Rating

Operating Temp Rating	-30°C to +55°C (-22°F - 131°F)
-----------------------	--------------------------------

Compatible Battery Profiles

- Lead Acid	- Calcium
- Lead Crystal	- Lithium Phosphate
- Ni-Cad 18 Cell	- VRLA-AGM
- Ni-Cad 20 Cell	- VRLA-GEL

Factory Load Test

Blue Star Power Systems, Inc. factory testing is performed with the same extreme diligence and attention to detail that is given to the prototype testing process. Every engine generator set receives a complete factory load test that certifies and ensures that the set will function in accordance to every specific application. Test metering will have an accuracy of 1.3% or better. This metering equipment is calibrated annually, and is directly traceable to the National Institution of Standards & Technology (NIST). All test procedures are conducted in accordance with MIL-STD-705C where applicable.



Factory Acceptance Testing Procedures

- Insulation Resistance Test (301.1c)*
- High Potential Test (302.1b)*
- Alternator Over Speed
- Complete Engine Inspection
- Generator Inspection
 - Winding Resistance Test (401.1b)
 - Exciter Field Stator
 - Main Field Stator
- Mounting & Coupling Inspection
- Engine Fuel System Inspection
- Engine Lube Oil System Inspection
- Engine Cooling System Inspection
- DC Charging System Inspection
- Main Output Circuit Breaker Inspection
- Anticipatory Alarms and Shutdowns Test (505.2b, 515.1b, 515.2b)
- Optional Equipment Inspection (513.2a)
- Load Test (640.1d)
 - Regulator Range Test (511.1d)
 - No Load
 - MAX Load @ 1.0 P.F. (640.2d)
 - MAX Load @ 0.8 P.F.
 - Block Loads @ 0-25%, 0-50%, 0-75%, 0-100% of rated load tests (640.2d)
- 1.0 Power Factor Max Load
- 1.0 Power Factor Max Block Load Pickup
- Full Name Plate Rated Load.
- Standard Readings Taken Every 5 Minutes.

* Performed By Alternator OEM

Standard Reading Recorded During Load Test Inspection

Run Time	AC Frequency
AC Voltage	Exciter Field Voltage
AC Amperage	Exciter Field Current
kVA	Lube Oil Pressure
kWe	Engine Coolant Temp.
Power Factor	Ambient Temp.

Factory Load Test Summary

All engine generator sets are visually inspected prior to testing. This includes a complete visual/mechanical inspection to ensure that all fasteners and electrical connections are secure, that all rotating components are free of obstruction/interference and are properly guarded.

Once the unit is started, the AC voltage and frequency are set to rated values. The unit is operated at no load while all of the safety shutdowns and warnings are verified and tested. The unit is then restarted and run at 25%, 50% and 100% of rated load and power factor until the engine temperature has stabilized for at least ten minutes. During the rated and maximum load pickup portion of the test, the voltage regulator gain, stability and under frequency compensation adjustments are set for optimal performance. All test procedures are performed in accordance with MIL-STD-705C where applicable.

Throughout these test procedures the AC parameters, engine oil pressure, engine temperature, exhaust temperature, timing and air/fuel ratio (gaseous units) are monitored and recorded. The unit and all installed accessory equipment are continually examined for oil and coolant leaks, excessive vibration and foreign noises.

Once all test procedures are performed and recorded, the unit is allowed a cool down period prior to being shut down. The unit is once again inspected for leaks, loose fasteners and connections prior to leaving the test facility.

The unit receives another complete final inspection process prior to packaging and shipment.

Note: All units are tested after the painting process is complete to prevent unforeseen difficulties resulting from the painting process being performed after testing.

Witnessed Factory Load Test

Standard witnessed factory load testing must be scheduled and approved at least four weeks prior to the engine generator sets scheduled shipping date. Any requests for witnessed factory load testing after this four week period may incur additional charges.

Witnessed Extended Run Factory Load Test

Witnessed extended run factory load testing must be scheduled and approved at the time of order placement. Any requests for witnessed extended run factory load testing after this time could be denied and would if approved incur additional cost.

All units are built and tested to cUL, CSA and NFPA 110 standards.



Engine Generator Set Two (2) Year 2000 Hour Standby Limited Warranty



Your Blue Star Power Systems, Inc. product has been designed and manufactured with care by people with many years of experience. Blue Star Power Systems, Inc. warrants to its Buyer that the product is free from defects in materials and/or workmanship for the period of time outlined below. If the product should prove defective within the time period outlined below, it will be repaired, adjusted or replaced at the option of Blue Star Power Systems, Inc., provided that the product, upon inspection by Blue Star Power Systems, Inc., has been properly installed, maintained and operated in accordance with Blue Star Power Systems, Inc.'s Installation and Operating Manuals. This limited warranty is not valid or enforceable unless: (1) all supporting maintenance records are kept on file with the end user and made available upon request from factory, and (2) the generator set is routinely exercised in accordance with operating instructions. This warranty does not apply to malfunctions caused by physical damage, misuse, improper installation, repair or service by unauthorized persons, or normal wear and tear. The warranty is not assignable.

Blue Star Power Systems, Inc. product warranty period: Engine generator set: Parts and Labor for two (2) years from the date of factory invoice or 2000 hours (whichever occurs first). Accessories (installed on the engine generator set or shipped loose): Parts and Labor for one (1) year from the date of factory invoice or 2000 hours (whichever occurs first). Transfer Switches: If purchased with a generator set (same order number): Parts and Labor for two (2) years from the date of factory invoice or 2000 hours (whichever occurs first).

The start of the warranty period can be adjusted to the date of unit start-up (limited to 180 days from invoice date) provided that the following information is provided to Blue Star Power Systems, Inc. within 30 days of start-up. The warranty will not be effective unless a copy of the Blue Star Power Systems, Inc. start-up validation checklist is properly and completely filled out and returned to Blue Star Power Systems, Inc. within 30 days of start-up. Additionally, the engine manufacturer's engine registration form must be completed and returned to the engine manufacturer as stated in the instructions with the registration form.

To obtain warranty service: Contact your nearest Blue Star Power Systems, Inc. Service Representative. For assistance in locating your nearest authorized service representative, contact Blue Star Power Systems, Inc., Attention: Service Department (see contact information below).

Warranty service may be performed by authorized Blue Star Power Systems, Inc. service providers only. Service work performed by unauthorized persons will void all warranties.

Blue Star Power Systems, Inc. shall not be liable for any claim in amount greater than the purchase price of the product. In no event shall Blue Star Power Systems, Inc. be held liable for any special, indirect, consequential or liquidated damages including but not limited to: loss of profits, loss of time, increased overhead, delays, loss of business opportunity, good will, or any commercial or economic loss.

Blue Star Power Systems, Inc. shall not be liable for any claim that requires replacement of engine, part, or component of the gen-set that is no longer manufactured or available. Additionally, Blue Star Power Systems, Inc. will not be liable for any engine replacement that may require emissions tier level change.

THERE ARE NO EXPRESS WARRANTIES OTHER THAN THOSE DESCRIBED HEREIN. THERE ARE NO OTHER WARRANTIES, EXPRESSED OR IMPLIED, OR OTHERWISE CREATED UNDER THE UNIFORM COMMERCIAL CODE, INCLUDING BUT NOT LIMITED TO WARRANTIES OF MERCHANTABILITY, OR WARRANTIES OF FITNESS FOR A PARTICULAR PURPOSE.

The following items and/or circumstances are excluded from this limited warranty:

- ▶ Engine starting batteries: The battery manufacturers' warranty applies. Consult your local battery supplier for warranty service.
- ▶ Fuel system and/or governing system adjustments performed during or after start-up.
- ▶ Normal maintenance items: Consumable items such as belts, filters, fluids, and hoses.
- ▶ Adjustments and tune-ups performed during start-up or thereafter. Start-up, training, tuning, and adjustments for any paralleling or bi-fuel system.
- ▶ Loose connections (electrical and mechanical) not found during start-up.
- ▶ All fluid level related items including low coolant not found during start-up or checked during regular maintenance intervals.
- ▶ Shipping damage of any type. All equipment is shipped F.O.B. Blue Star Power Systems, Inc. and risk of loss transfers to the carrier once loaded for shipment. It is the responsibility of the receiving party to sign for the receipt of, and note any shipping damage to the equipment. Freight damage claim filing is the responsibility of the receiving party. In the rare event that damage occurs during shipment, Blue Star Power Systems, Inc. will not warrant any damage to the unit resulting from shrink wrap.
- ▶ Any special access fees, equipment, requirements or after hours scheduling to gain access to the equipment for warranty service purposes.
- ▶ Buyer requested rental generators used while warranty work is being performed.
- ▶ Damages caused by acts of nature, such as lightning, wind, flood, or earthquake.
- ▶ Any damage due to situations beyond the control of the manufacturing and/or workmanship of the product.
- ▶ Use of non-protected steel enclosure within 10 miles of the coast.
- ▶ Improper installation or operation as outlined in the Installation and Operation Manuals.
- ▶ Misapplication of the equipment such as usage outside the original design parameters as stated on the nameplate of the equipment.
- ▶ Equipment purchased at the standby rating that is being used in a prime power application(s).
- ▶ Diesel engine "Wet Stacking" or Regeneration issues due to lightly loaded diesel engines.
- ▶ Travel labor and mileage for mobile generator sets.
- ▶ More than one trip to the job site because a service vehicle was not stocked with normal service parts.
- ▶ Lodging expense associated with unit repair and excessive mileage charges (limit to 300 miles round trip from nearest service center).
- ▶ Failure to properly exercise and maintain your equipment per manufacturer's specifications will void all warranty.
- ▶ Equipment modifications made without the written consent of Blue Star Power Systems, Inc. will void all warranties.
- ▶ Any equipment or components added including fuel tanks and enclosures not installed at the Blue Star Power Systems, Inc. factory.

This agreement is deemed made and executed in North Mankato, Nicollet County, Minnesota and shall be construed and interpreted in accordance with the laws of the state of Minnesota without giving effect to its conflicts of laws principals. Each of the parties submits to the exclusive personal jurisdiction and venue with respect to any action or proceeding arising out of, in connection with, relating to, or by reason of this agreement before the district court of the state of Minnesota, located in Nicollet County and agrees that all claims in respect of the action or proceeding may be heard and determined in any such court.



American Generators Sales & Service, LLC

6158 Delfield Drive, Ste. C

Waterford, MI 48329

Phone: (248) 623-4919 Fax: (248) 623-4918

August 10, 2023

City of Novi

Fire Station #3

42785 9 Mile Rd, Novi, MI 48375

REF: 50 kW Generator Installation Project

ATTN: Matt Turco

Mr. Turco,

Thank you for your interest in American Generators Sales & Service, LLC, products and services.

Below is a description of the Scope of Work for installing a "Standby Natural Gas Generator System" for above mentioned building

This System will allow complete power backup of the mentioned building, in its entirety.

This Scope is based on our conversations, site visit, and meeting with yourself. Please review this document and contact me with any questions.

SCOPE of WORK:

Provide and install the following:

- Blue Star GM50 (See Attached Spec Sheet)
 - 120/240V
 - Level 1 Weather Enclosure
 - 10A 12V Premium Battery Charger
 - Coolant Heater
- Concrete Pad – Per Manufacturers Specs
- Electrical Materials
- Gas Line Materials
- Labor
- Electrical Permit
- Mechanical Permit
- Freight / Delivery / Crane Service
- Project Commissioning & Testing
- Owners Training
- Project Close-out (Drawings, Manuals, Documentation, etc.)
- Reinstall existing Remote System Monitoring (cellular based) - Remote Start Capable Monitoring. (Annual Subscription of \$365.00) First Year Monitoring is Included. (optional, but included)
- Sales tax EXEMPT

NOT INCLUDED IN TOTAL PRICE

- Overtime

BLUE STAR

Power Systems Inc.

Submittal

8/10/2023

Project Title	City of Novi - FS#3
Quote Number:	0099825-0
Model:	GM50-03

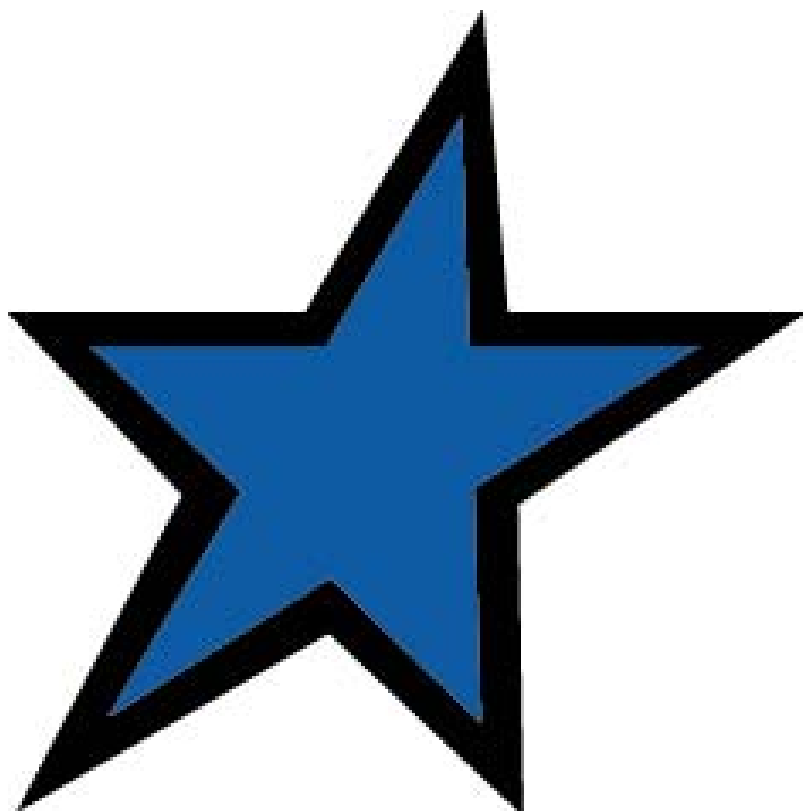

American Generators Sales & Service, LLC.
Doug Pletcher
6158 Delfield Dr.
Suite C
Waterford MI 48329
Office: 248-623-4919
Cell: 248-240-6036
Email: dpletcher@american-generator.com

BLUE STAR

Power Systems Inc.

Table of Contents

- Sales Quote
- Specification Sheet
- 5.7L Data Sheet
- 11 Industrial Alternators
- 14 MX321 Voltage Regulator
- 3 DCP7310 Control Panel
- 6 DSE2548 Remote Annunciator
- 44 Paint and Powder Coat
- 19 Enclosures
- 17 Radiators
- 22 Circuit Breakers
- 29 TPS Series Block Heaters
- 31 Single Stage Air Cleaner
- 33 CPJ Series Silencers
- 27 Industrial Batteries
- 26 Deep Sea Battery Charger
- 47 Factory Load Test
- 2yr 2000hr limited warranty

BLUE STAR

Power Systems Inc.

Sales Quote

Quote Date: 8/10/2023 1:53:47 PM
Quote Number: 0099825-0
Project Title: City of Novi - FS#3
Prepared for: American Generators Sales & Service, LLC.

Distributed by:



Unit Model	GM50-03	Standby / Prime	Emergency Stationary Standby
kWe Rating	50 kWe	UL 2200 Listed	Yes
Fuel	Natural Gas [NG]	CSA Approved	Yes
EPA	Certified	Paint Color	Gray

Fuel System: Natural Gas

Engine Model: General Motors 5.7L EPA 50kW Standby Power Rating at 1800 RPM Governor - Electronic Isochronous

Voltage: 240/120V 1 Phase 60 Hz 1.0 PF

Gen Model: Stamford UCI224F 12 Lead Wired 240V 1 Phase Double Delta 125°C Rise Over 40°C Ambient

Voltage Regulator: Stamford MX321 Automatic Voltage Regulator with PMG Excitation

Control Panel: Blue Star DCP7310 Microprocessor Based Gen-Set Controller Mounted Facing Left from Generator End (Unless Specified Otherwise)
Standard Features: Low Oil Pressure, High Coolant Temp, Overspeed, Overcrank Shutdowns
Emergency Stop Pushbutton, Audible Alarm Buzzer with Silencing Switch

Control Panel Options: Low Water Level Sensor with Shutdown

Remote Annunciator: Deep Sea DSE2548 (2x) Remote Annunciator with Enclosure (Surface Mounted)

Unit Color: Gray

Enclosure: Level 1 (Weather Proof Enclosure) Powder Coated 14 Gauge Steel Rugged and Durable 200 MPH Wind Rated Enclosure
Pitched Roof for Increased Structural Integrity and Improved Watershed
Punched Intake with Baffle and Punched Exhaust Openings
Keyed Alike Lockable Doors with Draw Down Latches and Stainless Steel Component Hinges
Formed Steel Base with Mounting and Lifting Holes
Includes Vibration Mounts to Isolate Unit from Base Rail

Sound Attenuation Foam: Sound Attenuation Not Included

Cooling: Unit Mounted Radiator (50°C Ambient)

Coolant Drain Extension: Plumbed to Bulkhead Fitting in Base

Oil Drain Extension: Plumbed to Bulkhead Fitting in Base

Mainline Breaker: 200 Amp 2 Pole 240 Volt Breaker Mounted & Wired in a NEMA 1 Enclosure

Jacket Water Heater: Engine Block Heater 1500W 120VAC Rated for -20°F
Heater Installed with Isolation Valves and Wired to Terminal

Air Cleaner: Dry Single Stage

Silencer: Critical Grade Compact (CPJ Series) Silencer Mounted to Engine

Battery: 12 Volt System with Rack and Cables

Battery Charger: DSE 12 Volt 10 Amp Mounted and Wired to Terminal

Factory Test: Standard Commercial Testing Includes:
Verification of Alarm Shutdowns, Voltage Settings, Block Loading to Rated kWe and PF

Owner's Manual: Print Copy (Qty 1) **Standard**, Electronic Copy, Flash Drive (Qty 1)

Warranty: 2 Year / 2000 Hour Limited

Notes:

**Additional Options
(Not Included in Price):**

ATS 1

Series	300	Volts	240/120V 1 PH
Service Entrance Rated	Yes	Poles	2
Amps	400	Enclosure	Nema 3R Secure

Warranty: Two (2) Year Basic ATS Limited Warranty Standard

Optional Accessories: 44G Strip Heater with Thermostat, Wired to Load Terminals (208-600V)
11BE Feature Bundle Includes Engine Exerciser/Event Log/RS-485 Enabled/Common AI

ATS Notes:

Payment Terms: Due Upon on Receipt

Lead Time: 40 + Weeks

Payment Terms: Due Upon Receipt

Delivery Schedule: 40 Weeks (Contingent on component availability)

Terms & Conditions

- This quote is valid for a period of 15 days.
 - This proposal is our interpretation of your requirement. It includes only the items listed on this quotation. Should there be other requirements or specifications, we will re-quote accordingly.
 - Units are shipped wet to include lube oil and 50/50 water and antifreeze mix unless otherwise noted in this quotation.
 - All extended piping, wiring, or other than listed above is performed by "others".
 - Seller is not quoting, offloading, job site startup, personnel instructions, field testing, or unit installation.
 - Quoted prices include normal testing, packaging, and instructional literature.
 - It is the distributor/purchaser and end user's responsibility to ensure that this equipment is operated in accordance with all applicable local, state, and federal laws and regulations governing the use and operation of this equipment.
-

Distributor Terms & Conditions

PAYMENT TERMS:

- 20% DOWN AT TIME OF ORDER PLACEMENT, 70% AT TIME OF EQUIPMENT DELIVERY, 10% NET 30 DAYS OR BY START UP, WHICHEVER COMES FIRST.
- TERMS BASED ON CREDIT APPROVAL.
- ALL LATE PAYMENTS WILL BE SUBJECT TO A SERVICE FEE OF 1.5% PER MONTH. CUSTOMER WILL BE RESPONSIBLE FOR ANY AND ALL COLLECTION COSTS, INCLUDING LEGAL FEES.
- ALL CREDIT CARD PAYMENTS WILL INCUR A 3% TRANSACTION FEE.

I HAVE READ AND INITIALED, AGREEING TO TERMS _____

TAX EXEMPT NO. _____ IF APPLICABLE

F.O.B. FREIGHT ALLOWED TO JOB SITE, CUSTOMER TO OFFLOAD

DELIVERY: TO BE DETERMINED AT TIME OF ORDER.
TENTATIVE DELIVERY IS BASED ON THE MANUFACTURER'S CURRENT LEAD-TIME;

THIS IS NOT A GUARANTEE TO SHIP AND SHOULD BE USED FOR PLANNING PURPOSES ONLY.

CANCELLATION CHARGES WILL APPLY. ORDERS IN PRODUCTION BY THE MANUFACTURER CANNOT BE CANCELLED.

ALL EQUIPMENT REMAINS THE PROPERTY OF AMERICAN GENERATORS SALES& SERVICE, LLC. UNTIL PAID IN FULL

ACCEPTED BY: SITE ADDRESS:

COMPANY _____

AUTHORIZED SIGNATURE TO RELEASE MATERIAL _____

PRINT NAME _____ DATE _____

BLUE STAR

Power Systems Inc.

Gaseous Product Line

208-600 Volt

GM50-03

60 Hz / 1800 RPM

50 kWe

Standby

Ratings

	240V	208V	240V	480V	600V
Phase	1	3	3	3	3
PF	1	0.8	0.8	0.8	0.8
Hz	60	60	60	60	60
Generator Model	UCI224F	UCI224E	UCI224E	UCI224D	UCI224D
Connection	12 LEAD DD	12 LEAD WYE	12 LEAD DELTA	12 LEAD WYE	4 LEAD WYE
kWe Nat (LP)	50 (50)	50 (50)	50 (50)	50 (50)	50 (50)
AMPS Nat (LP)	208 (208)	174 (174)	151 (151)	75 (75)	60 (60)
Temp Rise	125°C / 40°C	125°C / 40°C	125°C / 40°C	125°C / 40°C	125°C / 40°C

Standard Equipment

Engine

- Radiator Cooled Unit Mounted (50°C)
- Radiator Duct Flange (OPU Only)
- Blower Fan & Fan Drive
- Starter & Alternator
- Oil Pump & Filter
- Oil Drain Extension w/Valve
- Governor - Electronic Isochronous
- 12V Battery System & Cables
- Air Cleaner (Dry Single Stage)
- Critical Grade Silencer Mounted
- Flexible Fuel Connector
- EPA Certified

Generator

- Brushless Single Bearing
- Automatic Voltage Regulator
- ± 1% Voltage Regulation
- 4 Pole, Rotating Field
- 125°C Standby Temperature Rise
- 100% of Rated Load - One Step
- 5% Maximum Harmonic Content
- NEMA MG 1, IEEE and ANSI Standards Compliance for Temperature Rise

Additional

- Single Source Supplier
- UL 2200 & cUL Listed
- CSA Certified
- Seismic Certified to IBC 2021
- NFPA 110 / CSA C282 Compliant
- Microprocessor Based Digital Control Panel Mounted in NEMA 12 Enclosure
- Base - Formed Steel
- Main Line Circuit Breaker Mounted & Wired
- Battery Charger 12V 6 Amp
- Jacket Water Heater -20°F 1500W 120V w/Isolation Valves
- Vibration Isolation Mounts
- 2 Year / 2000 Hour Standby Warranty
- Standard Colors - White / Gray

Application Data

Engine

Manufacturer:	Power Solutions International	Displacement - Cu. In. (lit):	350 (5.70)
Model:	5.7L NA	Bore - in. (cm) x Stroke - in. (cm):	4.00 (10.2) x 3.48 (8.84)
Type:	4-Cycle	Compression Ratio:	9.40:1
Aspiration:	Natural	Rated RPM:	1800
Cylinder Arrangement:	8 Cylinder Vee	Max HP Stby (kWm):	113 (84.3)

Exhaust System

	Standby
Gas Temp. (Stack): °F (°C)	1,350 (732)
Gas Volume at Stack Temp: CFM (m³/min)	553 (15.7)
Maximum Allowable Exhaust Restriction: in. H ₂ O (kPa)	40.8 (10.2)

Cooling System

Ambient Capacity of Radiator: °F (°C)	122 (50.0)
Maximum Allowable Static Pressure on Rad. Exhaust: in. H ₂ O (kPa)	0.50 (0.12)
Water Pump Flow Rate: GPM (lit/min)	36.6 (139)
Heat Rejection to Coolant: BTUM (kW)	3,120 (54.6)
Heat Rejection to CAC: BTUM (kW)	N/A
Heat Radiated to Ambient: BTUM (kW)	677 (11.9)

Air Requirements

Aspirating: CFM (m³/min)	173 (4.90)
Air Flow Required for Rad. Cooled Unit: CFM (m³/min)	7,400 (209)
Air Flow Required for Heat Exchanger/Rem. Rad. CFM (m³/min)	Consult Factory For Remote Cooled Applications

Fuel Consumption

	Natural Gas	LP
At 100% of Power Rating: ft3/hr (m3/hr)	736 (20.8)	286 (8.09)
At 75% of Power Rating: ft3/hr (m3/hr)	592 (16.8)	262 (7.41)
At 50% of Power Rating: ft3/hr (m3/hr)	465 (13.2)	182 (5.15)
Fuel Inlet Size: NPT		1.00"
Fuel Pressure Required: in. H ₂ O (kPa)		11.0 (2.75)

Fluids Capacity

Total Oil System: gal (lit)	1.25 (4.73)
Engine Jacket Water Capacity: gal (lit)	2.03 (7.68)
System Coolant Capacity: gal (lit)	6.00 (22.7)

All calculations based on natural gas fuel.
Deration Factors: Altitude: Derate 3% Per 1,000 ft Over 4,200 ft

DCP7310 Control Panel

Standard Features

- Digital Metering
- Engine Parameters
- Generator Protection Functions
- Engine Protection
- CAN Bus (J1939) ECU Communications
- Windows-Based Software
- Multilingual Capability
- Remote Communications to DSE2548 Remote Annunciator
- 8 Programmable Contact Inputs
- 10 Contact Outputs
- RS485 Communicator Interface
- cULus Listed, CE Approved
- Event Recording
- IP 65 rating (with supplied gasket) offers increased resistance to water ingress
- NFPA 110 Level 1 Compatible

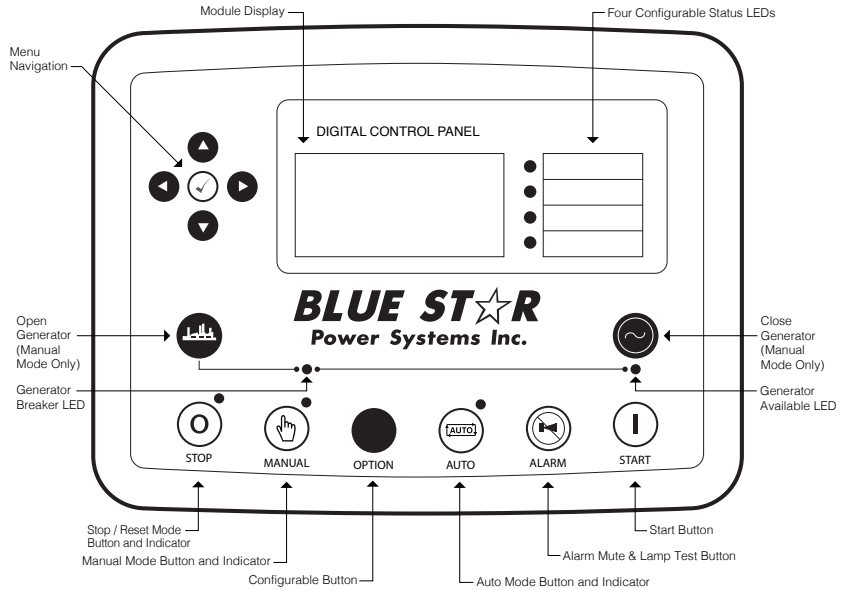

Weights / Dimensions / Sound Data

	L x W x H	Weight lbs
OPU	80 x 38 x 52 in	1,800
Level 1	90 x 38 x 60 in	2,275
Level 2	90 x 38 x 60 in	2,300
Level 3	120 x 38 x 60 in	2,450

Please allow 6-12 inches for height of exhaust stack.

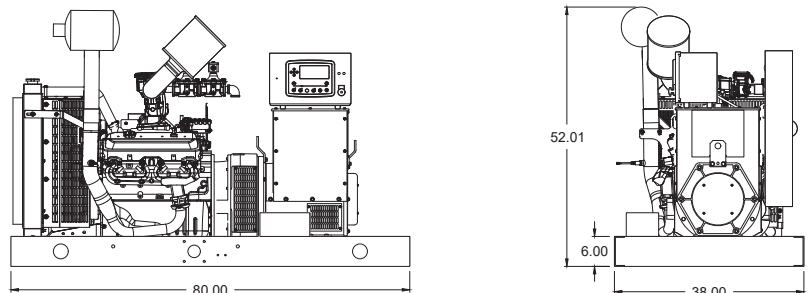
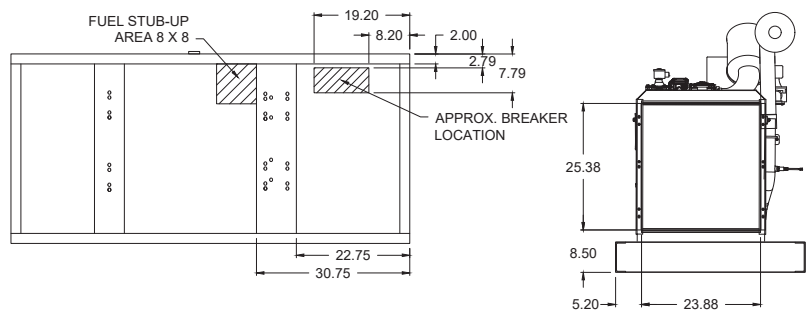

	No Load	Full Load
OPU	76 dBA	79 dBA
Level 1	71 dBA	73 dBA
Level 2	66 dBA	68 dBA
Level 3	63 dBA	64 dBA

Enclosures

Level 1 & 2 | Side View (Weather Proof)

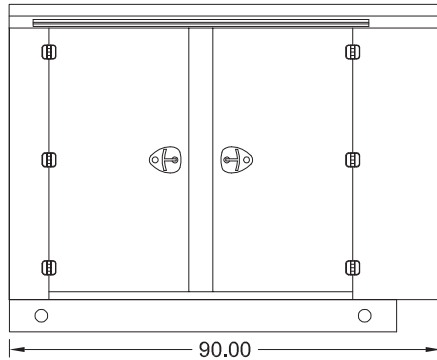

Level 3 | Side View (Sound Attenuated)

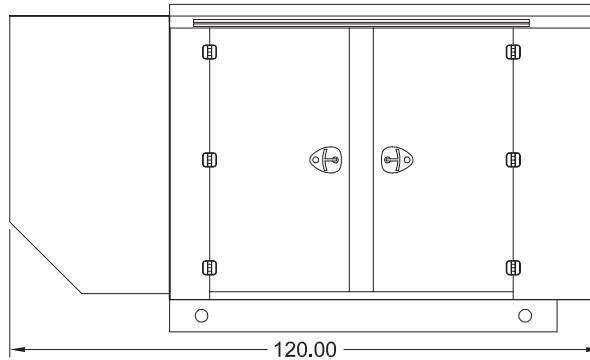

Level 1, 2 & 3 | Intake View

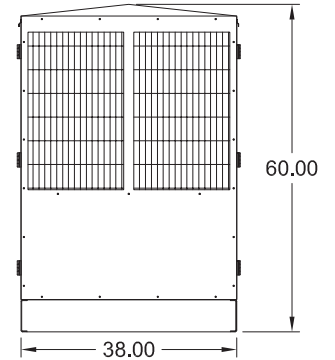

- All enclosure models are 200 MPH wind rating certified in accordance with IBC2021 and ASCE/SEI 7-16 standards.
- Level 2 & 3 enclosures include sound attenuation foam
- Level 3 enclosure includes frontal sound & exhaust hood.
- Enclosure height does not include exhaust stack.

Notes

- All specification sheet dimensions are represented in inches.
- All drawings based on standard 480 volt standby generator. Lengths may vary with other voltages. All drawings and dimensions subject to change without notice.
- All enclosures are based on the standard unit configuration. Any requested deviation can change dimensions.
- Sound data is measured at 23 feet (7 meters) in accordance with ISO 8528-10.
- All materials and specifications subject to change without notice.

American Owned



American Made

Blue Star Power Systems, Inc.

2250 Carlson Drive

North Mankato, Minnesota 56003

Phone + 1 507 345 1776

bluestarps.com

quote.bluestarps.com

sales@bluestarps.com



5.7L Naturally Aspirated Stationary

EMERGENCY "STANDBY"



Date:	10/28/2014
Rev:	C

Units		5.7L NA			
Std	Metric	1500		1800	

General Engine Data						
Type	N/A		GM V-Type 4 Cycle			
Number of cylinders	N/A		8			
Aspiration	N/A		Naturally Aspirated			
Bore	in	mm	4	101.6	4	101.6
Stroke	in	mm	3.48	88.4	3.48	88.4
Displacement	in ³	L	350	5.7	350	5.7
Compression Ratio	N/A		9.4:1			
RPM Range (Min-Max)	RPM		1500-1800			
Rotation Viewed from Flywheel	N/A		Counter Clockwise			
Firing Order	N/A		1-8-4-3-6-5-7-2			
Dry Weight (long Block)	lb	kg	432	196	432	196
Gross Standby Power Rating ^{1,2,3} Per ISO 3046 at the Flywheel			HP	KW	HP	KW
LP			94.30	70.32	113.16	84.38
Standby Rating Average Load Factor - LP			77.32	57.66	92.79	69.19
NG			87.28	65.08	104.73	78.10
Standby Rating Average Load Factor - NG			71.56	53.36	85.87	64.04
Please ask a PSI sales representative for information regarding prime power operation						
Exhaust System						
Type			Air Cooled Manifold			
Emergency Standby Rating Catalyst Configuration for US Certified Product			No Catalyst		No Catalyst	
Maximum allowable Back pressure	in HG	kPa	3	10.2	3	10.2
Exhaust Volumetric Flow at Rated Power @ 1350 F	cfm	m ³ /min	470.5	13.32	552.7	15.82
Air Induction System						
Maximum allowable Intake Air Restriction with Air Cleaner						
Clean	inH ₂ O	kPa	3	1.49	3	1.49
Dirty	inH ₂ O	kPa	13	3.24	13	3.24
Combustion Air required (volume)	cfm	m ³ /min	145.70	4.13	173.00	4.90
Cooling System						
Coolant Capacity						
Engine only	qts	L	8.1	7.8	8.1	7.8
Heat rejected to Cooling water at rated Load	btu/min	kcal/sec	2600	12.8	3120	13.1
Cracking Temperature	F	C	160	71	160	71
Full Open Temperature	F	C	185	85	185	85
Lubrication System						
Oil Specification			SAE 5W-30 API Rating of SM or Newer			
Maximum Allowable Oil Temperature	F	C	250	121	250	121
Engine Oil Capacity						
Min	Qts	L	5	4.7	5	4.7
Max	Qts	L	5	4.7	5	4.7
Fuel System						
Fuel Consumption @ Rated Load						
NG	lb/hr	kg/hr	33.9	15.37	38.2	17.32
LP	lb/hr	kg/hr	38.2	17.32	42.1	19.09
Maximum EPR Rated Pressure	psi	kPa	1.0	6.9	1.0	6.9
Recommended Maximum Running pressure to Electronic Pressure Regulator (EPR)	inH ₂ O	kPa	20.0	2.7	11.0	2.7
Recommended Minimum Running pressure to EPR	inH ₂ O	kPa	7.0	1.7	7.0	1.7
Minimum NG Supply Pipe Size			1-1/4" NPT			
Minimum LPG Supply Pipe Size ⁴			3/4"			

¹ Standby and overload ratings based on ISO 3046. See PSI technical standard 3630000A for additional duty cycle and engine rating information

² All ratings are gross flywheel horsepower corrected to 77°F at an altitude of 328feet with no cooling fan or alternator losses using heating value for NG of 1015 BTU/SCF.

³ Production tolerances in engines and installed components can account for power variations of +/- 5%. Altitude, temperature and excessive exhaust and intake restrictions should be applied to power calculations.

⁴ The preceding pipe sizes are only suggestions and piping sizes may vary with temperature, pressure, distance from supply and application of local codes. Gas must be available at adequate volume and pressure for engine at the EPR.

For information not listed in this document, please contact you PSI sales representative



**POWER SOLUTIONS
INTERNATIONAL**

201 Mittel Dr. Wood Dale, IL 60191
(630) 350-9400 Tel. • (630) 350-9900 Fax

PSI Technical Standard 36300000A- Engine Rating Guidelines

Emergency Standby Power Rating: Applicable for supplying emergency power for the duration of utility power outage. There is no overload capability for the emergency standby rating. Any use of the generator above the emergency standby rating is prohibited. Any unit operating in parallel with a public utility is not considered emergency standby. Emergency standby engine is applicable to a variable load with a maximum average load factor of 82% and 200 hours of operation per year. Emergency standby rating should only be applied in emergency power outages.

Prime Power Rating: Applicable for supplying electrical power in lieu of commercially purchased power or providing guaranteed standby power. The prime power rating is applicable for variable loads with limited number of operating hours per year. The average power output shall not exceed 75% of the prime power rating. The total time at 100% Prime power shall not exceed 500 hours per year. A 110% overload rating is available one hour in every twelve hours with the total hours at 110% not to exceed 25 hours per year. Maximum number of hours per year is 2500.

Continuous Power Rating: The continuous power rating is applicable for variable loads with unlimited number of operating hours per year. The power output shall not exceed 75% of the prime power rating. There is no overload capability.

Blue Star Power Systems, Inc. utilizes the highest quality alternators available. Our industrial alternators provide consistent performance, quality design, and great durability required for long life and versatility. Alternators used by Blue Star Power Systems, Inc. are UL and CSA Listed, which guarantees that each one meets the rigorous demands of industrial power generation and will provide safe and effective service for the life of the alternator. Blue Star Power Systems, Inc. alternators range from 20 kWe through 2000 kWe.



Standard Features

- **Enhanced Ventilation**
Created by a high-efficiency fan that optimizes internal airflow patterns, maximizes heat transfer, and minimizes hot spot differentials for extended winding life.
- **Fully Guarded**
For operator safety and alternator protection. No rotating or electrically energized parts are exposed. All openings are covered by louvers or screens.
- **Large Conduit Box**
Provides ample space for easy connections and allows load line access from all sides, top, or bottom.
- **Design Specs and Agency Approvals**
All Blue Star Power Systems, Inc. alternators are UL and CSA Listed (unless specified otherwise) and meet NEMA MG1-32, BS5000, CSA C22.2, IEC 34 and VDE 0530 requirements.
- **Class H Insulation System**
Utilizes an unsaturated polyester varnish for optimal insulation life and superior moisture protection.
- **Optimized Windings**
Provide low reactances and exceptional motor starting capability. The stator windings utilize a 2/3 pitch to minimize harmonic distortion and facilitate parallel operation.
- **Permanent Magnet Generator (optional)**
Ensures 300% short circuit current during fault conditions and provides the regulator with input power isolated from load distortion.
- **Heavy-Duty Bearing**
Resists contamination and gives a life expectancy up to 40,000 hours.
- **Automatic Voltage Regulator**
Provides accurate 1% regulation, under-speed protection, stability adjustment to optimize transient performance, and EMI filtering to commercial standards. Fully encapsulated for rugged durability in virtually any environment.

STAMFORD[®]

UCI224F - Winding 311 Single Phase

Technical Data Sheet

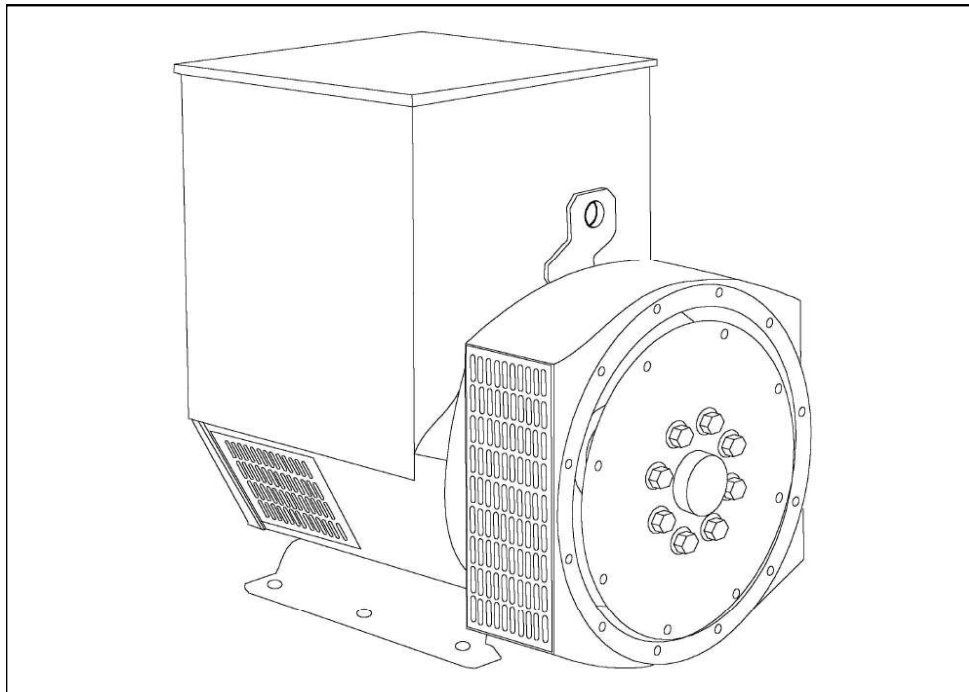

SPECIFICATIONS & OPTIONS

STANDARDS

Stamford industrial generators meet the requirements of BS EN 60034 and the relevant section of other international standards such as BS5000, VDE 0530, NEMA MG1-32, IEC34, CSA C22.2-100, AS1359.

Other standards and certifications can be considered on request.

VOLTAGE REGULATORS**SX460 AVR - STANDARD**

With this self excited control system the main stator supplies power via the Automatic Voltage Regulator (AVR) to the exciter stator. The high efficiency semiconductors of the AVR ensure positive build-up from initial low levels of residual voltage.

The exciter rotor output is fed to the main rotor through a three phase full wave bridge rectifier. This rectifier is protected by a surge suppressor against surges caused, for example, by short circuit.

AS440 AVR

With this self-excited system the main stator provides power via the AVR to the exciter stator. The high efficiency semi-conductors of the AVR ensure positive build-up from initial low levels of residual voltage.

The exciter rotor output is fed to the main rotor through a three-phase full-wave bridge rectifier. The rectifier is protected by a surge suppressor against surges caused, for example, by short circuit or out-of-phase paralleling.

The AS440 will support a range of electronic accessories, including a 'droop' Current Transformer (CT) to permit parallel operation with other ac generators.

MX341 AVR

This sophisticated AVR is incorporated into the Stamford Permanent Magnet Generator (PMG) control system.

The PMG provides power via the AVR to the main exciter, giving a source of constant excitation power independent of generator output. The main exciter output is then fed to the main rotor, through a full wave bridge, protected by a surge suppressor. The AVR has in-built protection against sustained over-excitation, caused by internal or external faults. This de-excites the machine after a minimum of 5 seconds.

An engine relief load acceptance feature can enable full load to be applied to the generator in a single step.

MX321 AVR

The most sophisticated of all our AVRs combines all the features of the MX341 with, additionally, over voltage protection built-in and short circuit current level adjustments as an optional facility.

WINDINGS & ELECTRICAL PERFORMANCE

All generator stators are wound to 2/3 pitch. This eliminates triplen (3rd, 9th, 15th ...) harmonics on the voltage waveform and is found to be the optimum design for trouble-free supply of non-linear loads. The 2/3 pitch design avoids excessive neutral currents sometimes seen with higher winding pitches, when in parallel with the mains. A fully connected damper winding reduces oscillations during paralleling. This winding, with the 2/3 pitch and carefully selected pole and tooth designs, ensures very low waveform distortion.

TERMINALS & TERMINAL BOX

Standard generators are reconnectable with 12 ends brought out to the terminals, which are mounted on a cover at the non-drive end of the generator. A sheet steel terminal box contains the AVR and provides ample space for the customers' wiring and gland arrangements. It has removable panels for easy access.

SHAFT & KEYS

All generator rotors are dynamically balanced to better than BS6861:Part 1 Grade 2.5 for minimum vibration in operation. Two bearing generators are balanced with a half key.

INSULATION/IMPREGNATION

The insulation system is class 'H'.

All wound components are impregnated with materials and processes designed specifically to provide the high build required for static windings and the high mechanical strength required for rotating components.

QUALITY ASSURANCE

Generators are manufactured using production procedures having a quality assurance level to BS EN ISO 9001.

The stated voltage regulation may not be maintained in the presence of certain radio transmitted signals. Any change in performance will fall within the limits of Criteria 'B' of EN 61000-6-2:2001. At no time will the steady-state voltage regulation exceed 2%.

DE RATES

All values tabulated on page 8 are subject to the following reductions

5% when air inlet filters are fitted.

3% for every 500 metres by which the operating altitude exceeds 1000 metres above mean sea level.

3% for every 5 C by which the operational ambient temperature exceeds 40 C.

Note: Requirement for operating in an ambient exceeding 60 C must be referred to the factory.

NB Continuous development of our products entitles us to change specification details without notice, therefore they must not be regarded as binding.

Front cover drawing typical of product range.

UCI224F



WINDING 311 Single Phase

CONTROL SYSTEM	SEPARATELY EXCITED BY P.M.G.		
A.V.R.	MX321	MX341	
VOLTAGE REGULATION	± 0.5 %	± 1.0 %	With 4% ENGINE GOVERNING
SUSTAINED SHORT CIRCUIT	REFER TO SHORT CIRCUIT DECREMENT CURVES (page 7)		

CONTROL SYSTEM	SELF EXCITED		
A.V.R.	SX460	AS440	
VOLTAGE REGULATION	± 1.0 %	± 1.0 %	With 4% ENGINE GOVERNING
SUSTAINED SHORT CIRCUIT	SERIES 4 CONTROL DOES NOT SUSTAIN A SHORT CIRCUIT CURRENT		

INSULATION SYSTEM	CLASS H		
PROTECTION	IP23		
RATED POWER FACTOR	0.8		
STATOR WINDING	DOUBLE LAYER CONCENTRIC		
WINDING PITCH	TWO THIRDS		
WINDING LEADS	12		
STATOR WDG. RESISTANCE	0.043 Ohms AT 22°C DOUBLE DELTA CONNECTED		
ROTOR WDG. RESISTANCE	0.83 Ohms at 22°C		
EXCITER STATOR RESISTANCE	20 Ohms at 22°C		
EXCITER ROTOR RESISTANCE	0.078 Ohms PER PHASE AT 22°C		
R.F.I. SUPPRESSION	BS EN 61000-6-2 & BS EN 61000-6-4, VDE 0875G, VDE 0875N. refer to factory for others		
WAVEFORM DISTORTION	NO LOAD < 1.5% NON-DISTORTING LINEAR LOAD < 5.0%		
MAXIMUM OVERSPEED	2250 Rev/Min		
BEARING DRIVE END	BALL. 6312-2RS (ISO)		
BEARING NON-DRIVE END	BALL. 6309-2RS (ISO)		

	1 BEARING	2 BEARING
WEIGHT COMP. GENERATOR	337 kg	350 kg
WEIGHT WOUND STATOR	120 kg	120 kg
WEIGHT WOUND ROTOR	110.69 kg	102.32 kg
WR ² INERTIA	0.6071 kgm ²	0.5754 kgm ²
SHIPPING WEIGHTS in a crate	360 kg	371 kg
PACKING CRATE SIZE	105 x 57 x 96(cm)	105 x 57 x 96(cm)

	50 Hz	60 Hz
TELEPHONE INTERFERENCE	THF<2%	TIF<50
COOLING AIR	0.216 m ³ /sec 458 cfm	0.281 m ³ /sec 595 cfm

	220/110	230/115	240/120	220/110	230/115	240/120
VOLTAGE DOUBLE DELTA	220/110	230/115	240/120	220/110	230/115	240/120
VOLTAGE PARALLEL DELTA	110	115	120	110	115	120
kVA BASE RATING FOR REACTANCE VALUES	48.5	48.5	48.5	50	52.5	56
X _d DIR. AXIS SYNCHRONOUS	2.28	2.09	1.92	2.68	2.57	2.52
X' _d DIR. AXIS TRANSIENT	0.18	0.16	0.15	0.22	0.21	0.21
X'' _d DIR. AXIS SUBTRANSIENT	0.12	0.11	0.10	0.15	0.14	0.14
X _q QUAD. AXIS REACTANCE	1.05	0.96	0.88	1.23	1.18	1.16
X'' _q QUAD. AXIS SUBTRANSIENT	0.15	0.14	0.13	0.14	0.13	0.13
X _L LEAKAGE REACTANCE	0.07	0.07	0.06	0.09	0.08	0.08
X ₂ NEGATIVE SEQUENCE	0.14	0.13	0.12	0.14	0.13	0.13
X ₀ ZERO SEQUENCE	0.11	0.10	0.09	0.11	0.10	0.10

REACTANCES ARE SATURATED	VALUES ARE PER UNIT AT RATING AND VOLTAGE INDICATED
T' _d TRANSIENT TIME CONST.	0.03 s
T'' _d SUB-TRANSTIME CONST.	0.008 s
T' _{do} O.C. FIELD TIME CONST.	0.75 s
T _a ARMATURE TIME CONST.	0.0065 s
SHORT CIRCUIT RATIO	1/X _d

**60
Hz**

UCI224F

STAMFORD

Winding 311 Single Phase

SINGLE PHASE EFFICIENCY CURVES

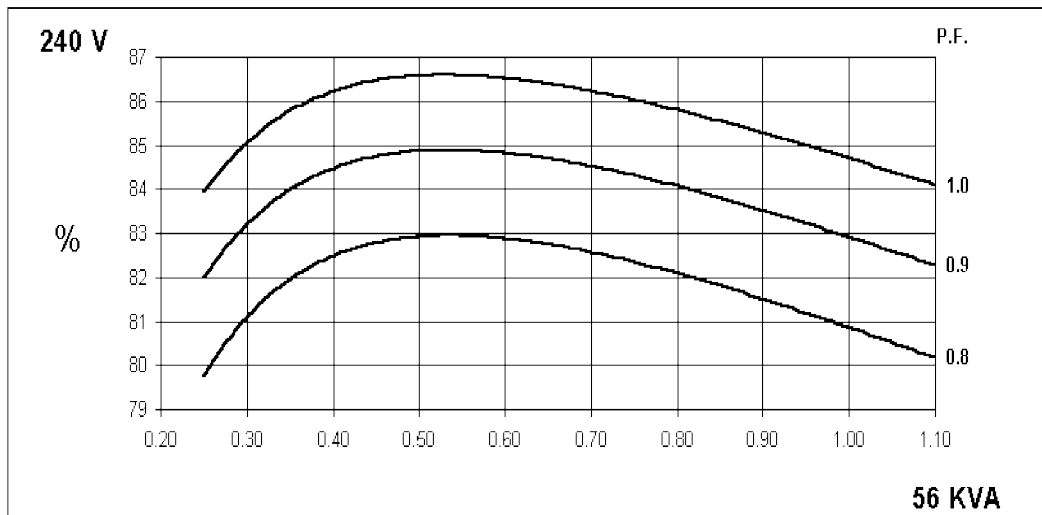
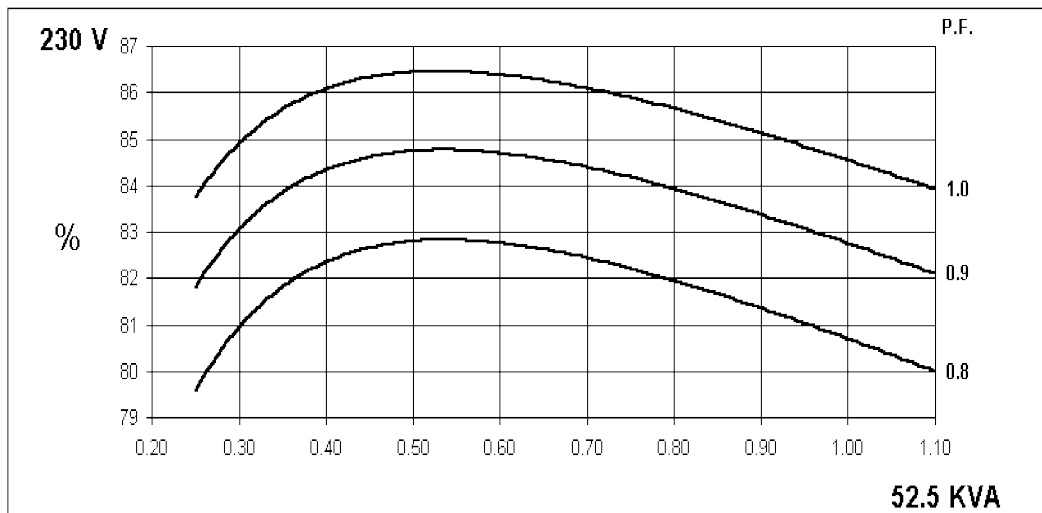
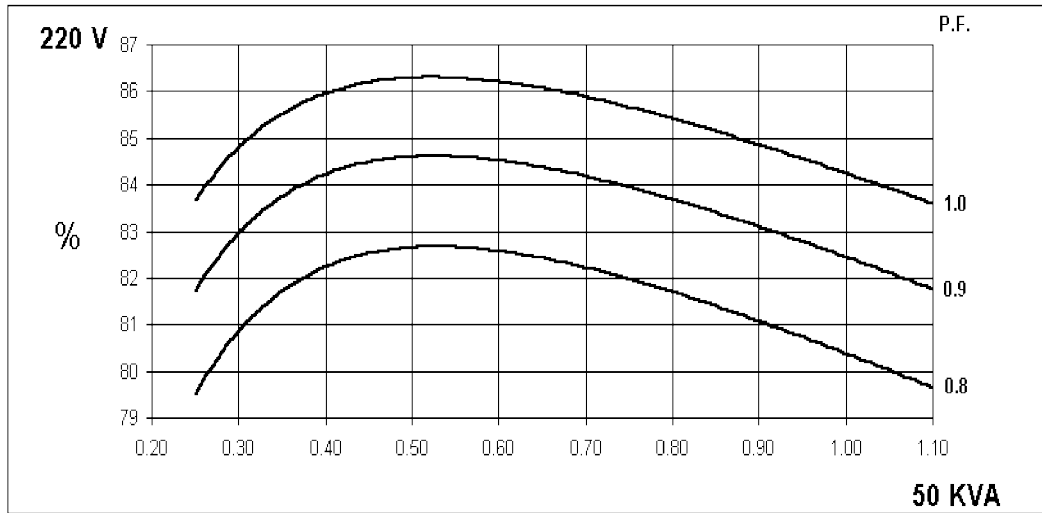

UCI224F

STAMFORD

Winding 311 Single Phase

Locked Rotor Motor Starting Curve

**60
Hz**

MX

SX

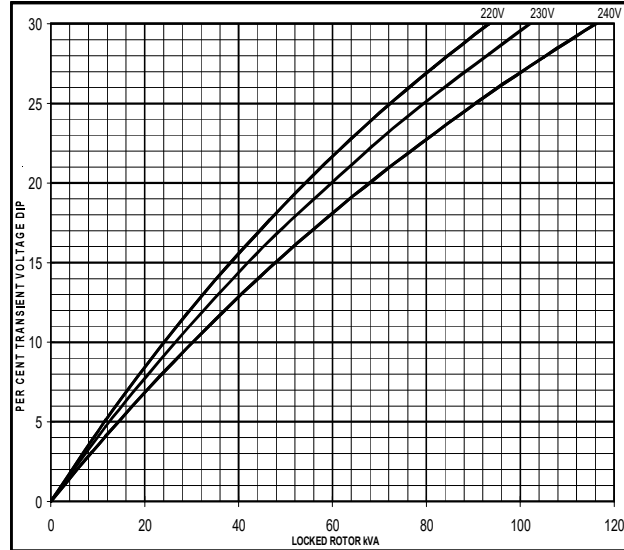
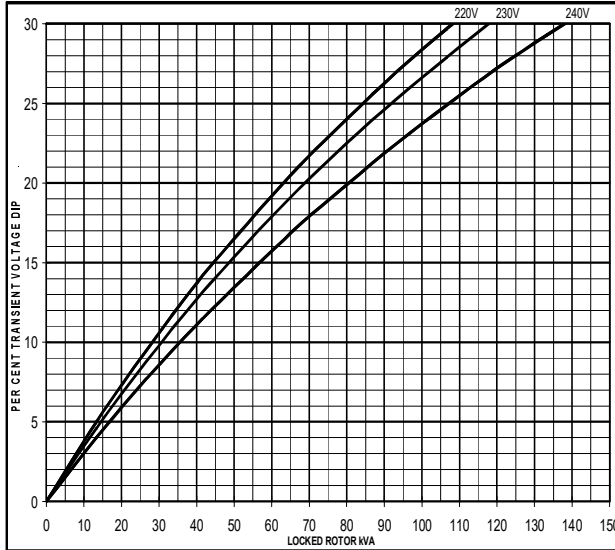

Winding 311 Single Phase Single Phase Short Circuit Decrement Curve. No-load Excitation at Rated Speed Based on Double Delta connection.

**60
Hz**

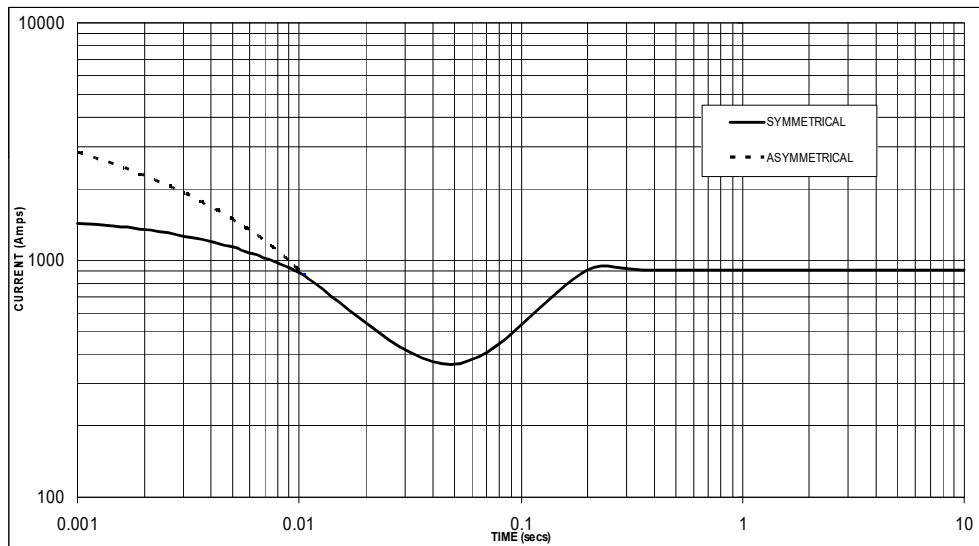

Sustained Short Circuit = 910 Amps

Note

The following multiplication factors should be used to adjust the values from curve between time 0.001 seconds and the minimum current point in respect of nominal operating voltage :

Voltage	Factor
220V	X 1.00
230V	X 1.05
240V	X 1.09

The sustained current value is constant irrespective of voltage level

UCI224F**STAMFORD****Winding 311 Single Phase****RATINGS**

Class - Temp Rise		Cont. F - 105/40°C 0.8pf			Cont. H - 125/40°C 0.8pf			Cont. F - 105/40°C 1.0pf			Cont. H - 125/40°C 1.0pf		
60	Double Delta (V)	220	230	240	220	230	240	220	230	240	220	230	240
	Parallel Delta (V)	110	115	120	110	115	120	110	115	120	110	115	120
	kVA	45.6	47.5	50.0	50.0	52.5	56.0	45.6	47.5	50.0	50.0	52.5	56.0
	kW	36.5	38.0	40.0	40.0	42.0	44.8	45.6	47.5	50.0	50.0	52.5	56.0
	Efficiency (%)	81.0	81.3	81.6	80.4	80.7	80.9	84.8	85.1	85.3	84.3	84.6	84.7
	kW Input	45.0	46.7	49.0	49.8	52.0	55.4	53.8	55.8	58.6	59.3	62.1	66.1

MX321 Voltage Regulator



MX321 is a three phase sensed Automatic Voltage Regulator and forms part of the excitation system for a brush-less generator. Excitation power is derived from a three-phase permanent magnet generator (PMG), to isolate the AVR control circuits from the effects of nonlinear loads and to reduce radio frequency interference on the generator terminals. Sustained generator short circuit current is another feature of the PMG system.

Voltage Adjustment

The screwdriver adjustable potentiometer adjusts the generator output voltage. Adjustment clockwise increases the generator output voltage.

When using a remote voltage adjust rheostat, remove the jumper wire across terminals 1 and 2 and install a 1k ohm 1 watt rheostat. This will give $\pm 10\%$ voltage variation from the nominal.

Stability Adjustment

The AVR includes a stability or damping circuit to provide good steady state and transient performance of the generator.

A jumper link selector is provided to optimize the response of the stability circuit to various size generators. The link should be positioned as shown in the diagram according to the kW rating of the generator.

The correct setting of the Stability adjustment can be found by running the generator at no load and slowly turning the stability control anti-clockwise until the generator voltage starts to become unstable.

The optimum or critically damped position is slightly clockwise from this point (i.e. where the machine volts are stable but close to the unstable region).

Under Frequency Roll Off (UFRO) Adjustment

The AVR incorporates an underspeed protection circuit which gives a volts/Hz characteristic when the generator speed falls below a presettable threshold known as the "knee" point.

The red Light Emitting Diode (LED) gives indication that the UFRO circuit is operating.

The UFRO adjustment is preset and sealed and only requires the selection of 50 or 60Hz and 4 pole or 6 pole, using the jumper link as shown in the diagram.

For optimum setting, the LED should illuminate as the frequency falls just below nominal, i.e. 47Hz on a 50Hz system or 57Hz on a 60Hz system.

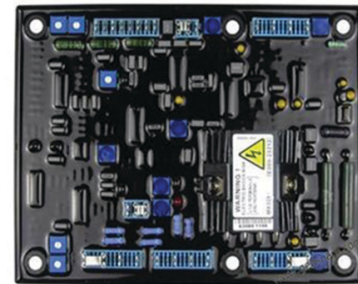

Specifications

Sensing Input

Voltage	190 to 264VAC max, 1 or 3 phase
Frequency	50 to 60 Hz Nominal

Power Input (PMG)

Voltage	170 to 220VAC, 3 phase
Current	3A
Frequency	100 to 120 Hz Nominal

Output

Voltage	max 120VDC
Current	Continuous 3.7A Intermittent 6A for 10 secs
Resistance	15 ohms Minimum

Regulation $\pm 0.5\%$ RMS

Thermal Drift 0.02% per 1°C change in AVR ambient

Soft Start Ramp Time 0.4 - 4 seconds

Typical System Response

AVR Response	10 ms
Field Current to 90%	80 ms
Machine Volts to 97%	300 ms

External Voltage Adjustment $\pm 10\%$ with 1k ohm 1 watt trimmer

Under Frequency Protection

Set Point	95% Hz
Slope	100 to 300% down to 30 Hz
Max. Dwell	20% volts/S Recovery

Unit Power Dissipation 18 watts Maximum

Analog Input

Maximum Input	± 5 VDC
Sensitivity	1V for 5% Generator Volts (Adjustable)
Input Resistance	1k ohm

Quadrature Droop Input 10 ohms Burden

Max. Sensitivity	0.22A for 5% Droop 0PF
Max. Input:	0.33A

Current Limit Input 10 ohms burden

Sensitivity Range	0.5 to 1A
-------------------	-----------

Over Voltage Detection Input 10 ohms Burden

Set Point	300V Time Delay: 1 sec (Fixed)
CB Trip Coil Volts	10 to 30VDC
CB Trip Coil Resistance	20 to 60 ohms
Time Delay	1 second (Fixed)

Over Excitation Protection

Set Point	75VDC
Time Delay	8 to 15 seconds (Fixed)

DCP7310 Control Panel



The DCP7310 is an Auto Start Control Module suitable for a wide variety of single, diesel or gas, generator set applications. The 7310 provides generator set control, transfer switch control, metering, monitoring & protection.

Key Benefits

- Real-time clock provides accurate event logging
- Multiple date and time scheduler
- Set maintenance periods can be configured to maintain engine performance
- Can be integrated into building management systems (BMS) using MODBUS
- Increased input and output expansion capability via DSENet®
- Licence-free PC software
- IP65 rating (with supplied gasket) offers increased resistance to water ingress
- PLC functionality
- Data logging to assist with fault finding and diagnosis
- cULus Listed

Advanced Features

- 4-Line back-lit LCD text display
- Five key menu navigation
- Front panel editing with PIN protection
- Customizable status screens
- Power save mode
- 8 Configurable inputs
- 6 Configurable DC outputs
- 2 configurable volt-free relay outputs
- Flexible sensor inputs
- Configurable timers and alarms
- 3 configurable maintenance alarms
- Multiple date and time scheduler
- Configurable event log (250 events)
- CAN engine support through FT4
- Integral PLC editor
- Easy access diagnostic page
- CAN and Magnetic Pick-up/Alt. inputs
- Fuel usage monitor and low fuel alarms
- Charge alternator failure alarm
- Load monitoring (kW, frequency, voltage)
- Support for 0V to 10V & 4mA to 20mA sensors
- LED and LCD alarm indication
- Power monitoring (kWh, kVA, kVAh, kVArh)
- Load switching (load shedding and dummy load outputs)
- Unbalanced load protection
- USB connectivity
- Backed up real time clock
- Fully configurable via DSE Configuration Suite PC software
- Remote SCADA monitoring via DSE Configuration Suite PC software
- User selectable simultaneous RS232, RS485
- Configurable MODBUS pages
- MODBUS RTU & TCP support
- Advanced SMS messaging (additional external modem required)
- Additional display screens to enhance with modem diagnostics
- Idle control for starting
- DSENet® expansion compatible



Specifications

DC Supply

Continuous Voltage Rating 8V to 35V Continuous

Cranking Dropouts:

Able to survive 0V for 100mS, providing supply was at least 10V before dropout and supply recovers to 5V. This is achieved without the need for internal batteries.

Maximum Operating Current 510mA at 12V, 240mA at 24V

Maximum Standby Current 330mA at 12V, 160mA at 24V

Charge Fail/Excitation Range 0V to 35V

Outputs

Output A (Fuel) 15ADC at Supply Voltage

Output B (Start) 15ADC at Supply Voltage

Outputs C & D (Volt free) 8A at 250VAC

Aux Outputs E to J 2ADC at Supply Voltage

Generator

Voltage Range (L-L) 26V to 719VAC

Voltage Range (L-N) 15V to 415VAC

Frequency Range 3.5 Hz to 75 Hz

Bus

Voltage Range 15V to 415VAC (L-N)

Frequency Range 3.5 Hz to 75 Hz

Magnetic Pickup

Voltage Range +/- 0.5V to 70V

Frequency Range 10,000 Hz (max)

Display

LCD Heated Display -40°F to 158°F

DCP7310 Control Panel



Front Panel LED Indicators:

- Manual: Indicates controller is in the MANUAL mode
- Stop: Indicates controller is in the STOP mode
- Auto: Indicates unit is in the AUTO mode
- Generator Available: Indicates when the generator is available to take load
- Generator Breaker: Indicates system is supplying current to a connected load
- Four Configurable Status LEDs: Configurable via DSE Configuration Suite PC software

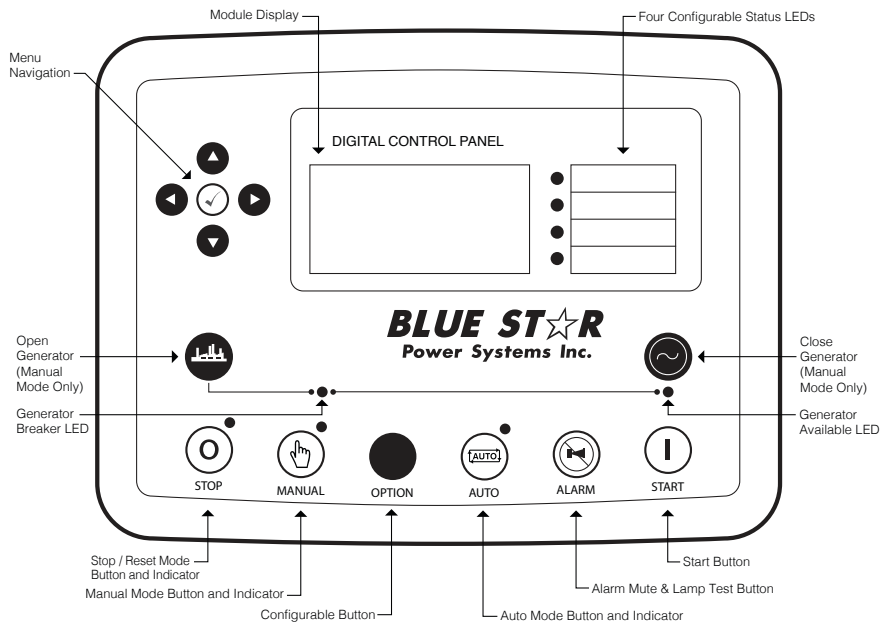

Standard Engine Protection Functions

Pre-Alarms (Warnings)

- Low Oil Pressure
- High Coolant Temperature
- Low Coolant Temperature
- Battery Overcharge (High Voltage)
- Weak Battery (Low Voltage)
- Low Load

- Def Level
- Battery Charger Failure
- Engine Sender Unit Failure
- Engine kWe Overload
- Maintenance Interval Timer
- Low Fuel Level
- Fuel Leak Detect

Alarms (Shutdowns)

- Low Oil Pressure
- High Coolant Temperature
- Overspeed
- Overcrank
- Fuel Sender Failure
- Def Level

All alarms and pre-alarms can be configured via the DSE Configuration Suite PC software or the front panel.

Optional Features

- Generator Protection - 27(2), 32, 40Q, 51(2), 59(2), 81O, 81U
- Enhanced Generator Protection - 51 and 47
- Selection of Integrating Reset or Instantaneous Reset Characteristics for Overcurrent Protection
- Ethernet and 4G (GSM) remote monitoring and communications via DSE WebNet Software
- Automatic Transfer Switch Control
- Remote Emergency Stop
- Multilingual Capability
- High Fuel Level Pre-Alarm
- Critical Low Fuel Level Alarm
- Analog Meters

Generator Protection

- Undervoltage (27)
- Overvoltage (59)
- Underfrequency (81U)
- Overfrequency (81O)
- Overcurrent (51)
- Reverse Power (32)
- Loss of Excitation (400)
- Phase Imbalance (47)

All generator protection features are programmable as alarms or pre-alarms.

DCP7310 Control Panel



DRP2510 Remote Display Panel

The DRP2510 is a display module designed to work with the DCP7310 Auto Start. Up to three display modules can be connected to one host control module, and can be positioned up to a maximum distance of 3,280 (1km) away. All remote displays connected to the same system, will show the same information at any one time, while the host controller is able to display different information. The modules are simple to operate, and feature the same user-friendly, menu layout as the host module. All communications and configuration are done via the host module only. The remote devices simply mirror the configuration of the host module, making the system quick and easy to install.

DSE2548 DSENET® Remote Annunciator

The DSE2548 is an LED expansion module that can be used with all DSENet® compatible control modules. The module has been designed to display a maximum of height individual LED indications up to a maximum distance of 3,280 (1km). The DSE2548 is presented in a vertical enclosure. It includes an alarm sounder that is triggered when the host controller detects an alarm condition. The alarm can be muted directly from the DSE2548 using the front push button. The DSE2548 includes individual LEDs for each channel and a 'Power On' LED that flashes when the link with the host controller is lost.

DSE890 MKII DSEWebNet® Gateway 4G (GSM/Ethernet) Remote Communications Interface

The DSE890 MKII 4G gateway is used in conjunction with supported DSE controllers to provide remote monitoring and communications data via the DSEWebNet® software. The DSE890 MKII gateway communicates with a maximum of five connected DSE controllers, monitoring their instrumentation and operating states. The DSEWebNet® software is accessed using an internet browser or mobile app connection. Users are able to perform multiple tasks including: monitoring equipment, clearing alarm conditions and starting/stopping equipment at the click of a button.

DSE2157 DSENET® Output Expansion Module

The DSE2157 is an output relay expansion module for use with DSENet® compatible control modules. The DSE2157 has been designed to extend a host module's output capabilities. A maximum of 10 DSE2157's can be connected to an individual module at any one time. All outputs are configurable via the host controller. The additional output capabilities of the DSE2157 give OEMs the flexibility to meet increasingly complex industry specifications.

DSE2130 DSENET® Input Expansion Module

The DSE2130 is an input expansion module for use with DSENet® compatible control modules. The additional input capabilities of the DSE2130 give OEMs the flexibility to meet increasingly complex industry specifications. The DSE2130 provides an additional eight digital inputs, with four of these configurable for use as analog inputs. All inputs are configured within the host controller.

DSE2133 DSENET® RTD / Thermocouple Input Expansion Module

The DSE2133 Input Expansion Module is used in conjunction with supported DSENet controllers to provide 8 additional configurable inputs. Up to four modules can be linked together to provide up to 32 additional inputs. The inputs can be configured as RTD or Thermocouple inputs in the 'host controller'.

DSE2131 Ratiometric Input Expansion Module

The DSE2131 Ratiometric Input Expansion module is used in conjunction with supported DSENet controllers to provide additional, flexible, input functionality. The ratiometric inputs can be configured in a number of ways to connect to digital switches, resistive sensors, 0 to 10VDC signals or 4 to 20 mA signals.

DSE2152 Analog Output Expansion Module

The DSE2152 Analog Output Expansion Module is used in conjunction with supported DSENet controllers to provide 6 additional outputs. The outputs can be individually configured as 0 to 10V or 4 to 20mA, via the "host controller". Up to four DSE2152 modules can be linked together to provide up to 24 additional outputs. An ID switch is provided on the module for identification.

DSE2548 Remote Annunciator



The DSE2548 is a powerful remote display to match Blue Star Power Systems, Inc. DCP7310 control panel. It may be powered from the engine starting batteries at 12V, 24VDC, or AC to DC converter. The DSE2548 uses DSENET communications between itself and the DCP to reduce the number of wires required to activate all the alarms. The DSENET communications can be used on remote displays up to 3,280 (1km) feet away from the DCP. The DSE2548 has 9 LEDs per annunciator for a total of 18 LEDs to indicate Alarms, Pre-Alarms and operating conditions of the emergency standby generator system. The DSE2548 also comes complete with a box for easy installation. The DSE2548 is available in two mounting configurations: surface and semi-flush mount. These panels comply with the requirements of NFPA 110.



Key Benefits

- Annunciation of 16 alarms and pre-alarms as detected by the DCP
- Annunciation of 2 status indicators
- Audible alarm horn
- Lamp Test and Alarm Silence switches
- Power supply inputs for 12V or 24VDC
- DSENET communications
- Two mounting configurations
- Box included
- Designed for use in harsh environments
- Works up to 3,280 (1km) from the host controller
- 10 modules can be linked together to one host controller
- Eight configurable LEDs

ID Switch

The rotary ID switch is used to select the address of the DSE2548 expansion module, as the host control module is capable of giving instructions to a number of DSE2548 expansion modules at the same time.

Operating Range

- Up to 3280 ft. from the DCP7310
- Recommended Wire - Belden 9841

Specifications

DC Supply

Continuous Voltage Rating 8V to 35V Continuous

Cranking Dropouts:
Able to survive 0V for 50mS, providing supply was at least 10V before dropout and supply recovers to 5V. This is achieved without the need for internal batteries. LEDs and backlight will not be maintained during cranking.

Maximum Operating Current 112mA at 12V, 53mA at 24V

Maximum Standby Current 74mA at 12V, 35mA at 24V

Dimensions

Overall 14"W x 10"H x 5.45"D
355.6 mm x 254 mm x 138.4 mm

Panel Cut-Out 12.50"L x 8.50"H
317.5 mm x 215.9 mm

Panel Thickness 1.45"
36.8 mm

Environmental Testing Standards

Electro-Magnetic Compatibility

BS EN 61000-6-2	EMC Generic Immunity Standard for the Industrial Environment
BS EN 61000-6-4	EMC Generic Emission Standard for the Industrial Environment

Electrical Safety

BS EN 60950	Safety of Information Technology Equipment, including Electrical Business Equipment
-------------	---

Temperature

BS EN 60068-2-1	Ab/Ae Cold Test -30°C
BS EN 60068-2-2	Bb/Be Dry Heat +70°C

Vibration

BS EN 60068-2-6	Ten sweeps in each of three major axes 5 Hz to 8 Hz @ +/-7.5mm, 8 Hz to 500 Hz @ 2 gn
-----------------	--

Humidity

BS EN 60068-2-30	Db Damp Heat Cyclic 20/55°C @ 95% RH 48 Hours
BS EN 60068-2-78	Cab Damp Heat Static 40°C @ 93% RH 48 Hours

Shock

BS EN 60068-2-27	Three shocks in each of three major axes 15 gn in 11 mS
------------------	---

Degrees of Protection Provided by Enclosures

BS EN 60529	IP65 - Front of module when installed into the control panel with the supplied sealing gasket.
-------------	--

Generator Set

Blue Star Power Systems, Inc. completely paints all of its generator sets in our state-of-the-art downdraft paint booth. It begins with an extensive cleaning of the unit through sanding and a full wipe down using an alkaline-based cleaner. Once completely clean, the unit is then painted with Cardinal Industrial Semigloss paint. Electrostatic paint equipment ensures correct and even coverage. The unit then receives a complete covering of Cardinal Industrial Clear Coat in a hammer texture to provide extra protection and a durable long-lasting easy-to-clean finish.

Performance Characteristics

- 3.0+ Mils TDFT
- Xenon Arc 1100 hours - Excellent Weatherability
- 1000 Hour Salt Spray - Over Primer - Passed (3.0 Mils Total TDFT)
- Adhesion, Crosshatch - 5B
- Gloss 90+ @ 60°

Generator Set Enclosure

Blue Star Power Systems, Inc. provides Cardinal Industrial Hammer Textured Semi-Gloss Polyester Powder Coating as standard on all our enclosures. Long term exterior durability, high performance mechanical properties and high gloss are standard characteristics of Cardinal Powder Coating. Cardinal TGIC Polyester Coating exceeds UL 2200 & CSA requirements.

Performance Characteristics

- Cured Powder Properties 2.0+ Mils DFT
- PCI Powder Smoothness 1 Mil
- Pencil Hardness 2H+
- Flexibility 1/8 in Diameter - No Fracture
- Salt Spray ASTM-B117 1000 Hours - Pass
- Humidity ASTM-02247 1000 Hours - Pass
- Adhesion, Crosshatch - 5B
- Gloss 90+ @ 60°

Standard Colors

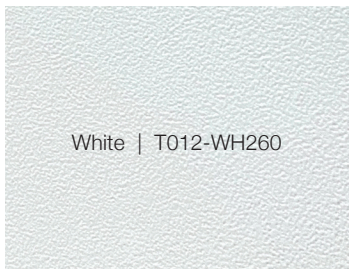

Custom Colors

Custom Colors: Blue Star Power Systems, Inc. offers custom color options for your generator set enclosure. Cardinal is licensed by PANTONE® to accurately simulate both the PANTONE MATCHING SYSTEM® colors and the PANTONE® Textile Color System® with our powder and liquid coatings. Additional Charges apply.



Sub-Base Fuel Tanks

Blue Star Power Systems, Inc. provides either Diamond Vogel Nexgen Technology Paint or Cardinal Industrial Hammer Textured Semi-Gloss Polyester Powder Coat on all of our sub-base fuel tanks. Nexgen and Cardinal Industrial both offer excellent coverage and performance characteristics. Nexgen and Cardinal Industrial both exceed UL requirements.

Performance Characteristics

- 3.0+ Mils TDFT
- Xenon Arc 1100 Hours
- 500 Hour Salt Spray - Over Primer - Passed (3.0 Mils Total TDFT)
- Adhesion Crosshatch - 5B
- Gloss 90+ @ 60°

Standard Color



Blue Star Power Systems, Inc. enclosures are specifically designed for optimal protection against the elements. They are designed to protect the entire system from even the most extreme environments, and to reduce sound levels to most specified requirements. Blue Star Power Systems, Inc.'s vast flexibility allows the design of standard enclosures to meet most specifications or requirements. All standard enclosure models are constructed of 14 gauge steel and feature a pitched roof for increased structural integrity and superior watershed. All enclosures feature a rugged UL listed hammer powder coat finish as standard for a long lasting and durable finish in standard white or gray. Custom colors are available as specified.

Enclosure Design Features



- UL 2200 & CSA Listed as standard
- All enclosure models are 200 MPH wind rating certified in accordance with IBC2018 and ASCE/SEI 7-16 standards.
- Lockable gasketed doors with draw down latches and Stainless Steel component hinges
- All Stainless Steel fasteners
- UL & CSA listed extreme-wear hammer powder coat finish
- Pitched roof for high structural integrity and superior watershed
- Above-door drip guards
- Optimal airflow means no cooling system de-rates on most models
- Internally mounted exhaust silencers standard up to 600 kW
- Sound attenuation options
- Stainless Steel and Aluminum enclosure options

Level 1

Weather Proof Enclosure

Blue Star Power Systems, Inc. Level 1 enclosures have the rugged construction and weather proof protection required for most outdoor environments. These enclosures will effectively protect the gen-set through high wind (200 MPH), rain, snow, and other extreme weather conditions. Weather proof enclosures feature standard hinged lockable doors, a pitched roof to prevent water accumulation and improved structural integrity. The enclosure is painted with extreme-wear UL and CSA listed hammer powder coat finish.

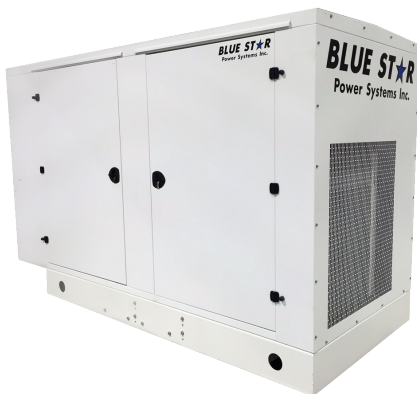

Level 2

Weather Proof Enclosure with Foam

Blue Star Power Systems, Inc. Level 2 enclosures include all of the same great features of the Level 1 enclosures, and include even more. With the addition of high performance 1.5" Type D Sound Attenuating Foam, our Level 2 Enclosures offer an even lower dBA rating with the same great weather proof protection.

Level 3

Sound Attenuated Enclosure

Blue Star Power Systems, Inc. Level 3 enclosures feature the same great weather proof protection and standard features as the Level 1 & 2 enclosure models, but with a greater emphasis on reducing sound levels. Standard Level 3 features include the same high performance 1.5" type D sound attenuating foam, and also feature the addition of a separate frontal exhaust sound chamber and dual rear air intake to ensure that your system runs exceptionally quiet. These features make this enclosure among the best in the industry for noise reduction and quality.



Radiators

Blue Star Power Systems, Inc. radiators offer a variety of styles and configurations including radiator and charged air assemblies, radiator and aftercooler assemblies with durable core construction. Our radiators are compact and efficient meeting the most stringent enclosure footprint requirements. All radiators are sized for 50°C (122°F) ambient. The single-source design ensures a perfect match with your generator set package.

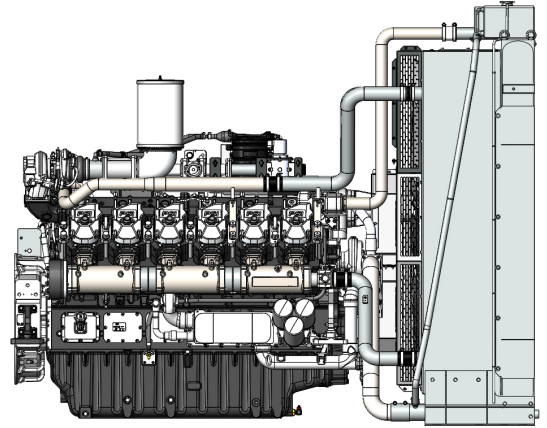

Radiator Features

Standard Radiator Package

- Engine-specific tank design with variant coolant connection locations and sizes (dependant on engine size)
- Complete cooling package with mounting foot and plumbing kit
- All steel construction of top and bottom tanks
- Dual Core designs -
 - Jacket Water / Charged Air Circuit
 - Jacket Water / After Cooler Circuit
- Individual radiators designed to meet manufacturer's specific requirements
- Top tank has built in expansion capacity - no need for an external recover tank
- Full or partial deration system built into the top tank
- Standard cooling package includes fan shroud & fan guard
- Corrosion preventive options:
 - Hot dipped galvanizing on all steel parts or stainless steel
 - Epoxy coated cores

Fan-On Radiator Design

- Engine-specific tank design with variant coolant connection locations and sizes (dependant on engine size)
- Rigid built construction for fan support
- High speed bearings within pillow blocks
- Dual Core designs with variable jacket water / after cooler circuit designs
- All steel construction of top and bottom tanks
- Individual radiators designed to meet manufacturer's specific requirements

Circuit Breakers



Blue Star Power Systems, Inc. MC (Molded Case) Series Circuit Breakers are the highest quality in the industry. They will protect the power system and corresponding equipment from damaging fault currents circuits and overloads.

80% Rated Circuit Breakers

80% rated breakers can only be applied continuously at 80% of the rated breaker. Tripping of the circuit breaker if the current goes above 80% will depend on the amount of current and the duration.

100% Rated Circuit Breakers

100% rated breakers can be applied at 100% of their current rating continuously.

Accessories

Shunt Trip - Provides a means of tripping the circuit breaker from a remote source by energizing a solenoid in the breaker. This can be achieved through the panel faults such as engine shutdowns, overcurrent, etc. The circuit breaker will have to be reset locally in the event of a tripped breaker.

Bell Alarm / Alarm Switch - Provides remote indication of whether the circuit breaker is in a tripped position. The bell alarm will remain unchanged during on-off operations and during operation by the Push-to-Trip button on the circuit breaker.

Auxiliary Switch/Contacts - Provides remote indication of whether the circuit breaker is in an open or closed state.

Ground Fault Indication/Alarm - Adjustable relay that indicates a ground fault condition with adjustable time delay.

Trip Unit

LI Breakers - Includes adjustable Long-Time pickup and delay and adjustable Instantaneous pickup.

LSI Breakers - Includes features of LI Breakers with addition of Short-Time pickup and delay.



Breaker Model	Amperage	Percentage Rated	Maximum Voltage Rating (AC)	UL Listed Interrupting Rating (kA)			Lug Qty. and Size (Cu & Al)
				240	480	600	
H-Frame	15-150	80% or 100%	600	25	18	14	(1) #14-3/0
Q-Frame	70-250	80%	240	10	-	-	(1) #4-300 kcmil
J-Frame	150-175	80% or 100%	600	25	18	14	(1) #4-4/0
	200-250						(1) 3/0-350 kcmil
L-Frame	125-400	80% or 100%	600	65	35	18	(2) 2/0-500 kcmil
	200-600	80%	600				
M-Frame	300-800	80%	600	65	35	18	(3) 3/0-500 kcmil

Breaker Model	Frame Size	Percentage Rated	Maximum Voltage Rating (AC)	UL Listed Interrupting Rating (kA)			Lug Qty. and Size (Cu & Al)
				240	480	600	
P-Frame	600	80% or 100%	600	65	35	18	(3) 3/0-500 kcmil
	800						
	1000						(4) 3/0-500 kcmil
	1200						
R-Frame (LSI Standard)	1600	100%	600	65	35	18	(12) 3/0-750 kcmil
	2000						(15) 3/0-750 kcmil
	2500						(18) 3/0-750 kcmil
	3000						(21) 3/0-750 kcmil

TPS Series Block Heaters



The TPS engine block heater is designed to preheat diesel and gaseous engines. It is simple to install, lightweight, and heats engines up to 12L displacement. Thermosiphon circulation of the coolant delivers even heat throughout the entire engine block.

Features

- cULus Listed
- CE Compliant
- Various temperature settings available, including an optional adjustable thermostat 90° - 130°F (32° - 54°C)
- Can be supplied with UL marked 120 or 240V NEMA plug



Specifications

Part Number	Volts	Watts	Amps	Male Plug	Outlet Size (Inches)
13224	120	500	4.2	Yes	5/8
14209	240	500	2.1	Yes	5/8
10014	120	1000	8.4	Yes	5/8
10015	240	1000	4.2	Yes	5/8
10016	120	1500	12.5	Yes	5/8
10017	240	1500	6.3	Yes	5/8
10018	120	1800	15	Yes	5/8
10019	240	2000	8.3	Yes	5/8

Single Stage Air Cleaner



Single Stage Air Cleaners are tough, non-metallic, lightweight, self-supporting and completely disposable. They are also easy to install, durable, and reliable. They are designed to function well under high and severe pulsation conditions found in many applications. Vibration-resistant media is potted into molded housings of rugged ABS plastic – so they don't fall apart as other designs might. They can be mounted vertically or horizontally.



Specifications

- No serviceable parts - Air cleaner housing and filter are one unit
- Designed to withstand severe intake pulsation
- Economical replacement cost
- Self-supporting, sturdy
- Very reliable: only one critical seal
- Lightweight and compact in size
- Non-metallic, non-corrosive
- Completely disposable - acceptable for normal trash pick-up (should not be incinerated)
- Easily installed and maintained
- Minimal removal clearance needed: only 1.5"
- Three airflow styles available to fit virtually any engine intake configuration
- Various media available for specific generator set applications: high pulsation, high humidity, etc.
- Temperature tolerance: 180°F/83°C continuous 220°F/105°C intermittent

CPJ Series Critical Grade Silencers



Blue Star Power Systems, Inc. "CPJ" Series is the accumulation of research and development offering a compact silencer without compromising performance. It incorporates a unique combination of resonator chambers, acoustically packed internal components and diffusers to achieve a stunning level of performance for its size. All CPJ series silencers are critical grade silencers and are packed with insulation to greatly reduce radiated noise and exterior shell temperature.

Standard Construction Features

- Available in sizes from 2 inch to 12 inch
- Multitude of inlet/outlet design styles to meet almost any requirement
- Packed with fiberglass insulation to reduce shell temperature and noise levels
- Fully welded double shell carbon steel weldment construction, corrosive resistant
- High density fiberglass acoustic blanket good to 1500°F, wrapped with 304 Stainless Steel wire mesh cloth and encased in a carbon steel perforated facing
- Black phenolic resin based finish paint



Optional Construction Features and Accessories

- Stainless Steel construction
- Aluminum construction
- Aluminized Steel construction
- Vertical mounting legs
- Round mounting bands
- Horizontal mounting saddles
- Horizontal and vertical shell lugs
- Special finish per specification
- Air leak test
- ASME code construction
- Oversized flanges
- Acoustic shell lagging
- High temperature acoustic pack material
- Contact factory for additional features to meet your requirements

Model #	Part #	Outlet Size	Flanged Connection	WT (lbs)
CPJS-02	10660	2.0" OD	No	12
CPJS-25	10661	2.5" OD	No	18
CPJS-03	10662	3.0" OD	No	20
CPJS-35	10663	3.5" OD	No	30
CPJS-04	10664	4.0" OD	No	31
CPJS-05	10665	5.0" OD	No	50
CPJS-06	10666	6.0" OD	Yes	50
CPJS-08	10667	8.0" OD	Yes	120
CPJS-10	10668	10.0" OD	Yes	180

Engine Starting Batteries

Blistering heat and bitter cold are ruthless battery killers. That's why Blue Star Power Systems, Inc. utilizes a pioneered climatized battery. Designed to offer you long-life and high-performance starting power that will get your gen-set running even under extreme conditions. Blue Star Power Systems, Inc. "all-climate" batteries stand up to the harshest temperatures and are available in sizes and configurations to fit almost any application.



Standard Features

- Unique Manifold Vent - Virtually eliminates corrosion by venting gases away from terminals and cables
- Exclusive TRP™ Construction – Rib reinforced TRP™ container significantly improves the vibration and impact resistance
- Armored Plate Cell Bonding - Vibration is the number one killer of commercial batteries. To solve this problem, the cells of every battery are bonded
- Polyethylene Enveloped Separator Design – Super tough polyethylene material reduces electrical resistance and provides higher cranking performance
- Center Lug Design - Suppresses the vibration inherent in traditional construction for improved performance (where applicable)
- TTP™ - Through-the-Partition inter-cell connectors create a shorter current path to deliver more power to the terminals
- Heavy Duty Cases - Reinforced polyethylene or hard rubber cases stand up to the demands of standby gen-sets
- Convenient Lifting Slots - a handle is built in the top of the battery for easy carrying and transportation
- Protective Bottom Design - Waffled bottom design provides protection against nuts, bolts, or stones that might become lodged under the battery
- Computer Designed Radical Grids - An improved state-of-the-art design which adds power and resists vibration
- Threaded Accessory Ports - Features a sealed "O" ring that does not work loose during severe service (78DT only)

Specifications

BCI Group Size	NEMA Type			Dimensions (Inches)			
	Part Number	CCA at 0°F	CCA at 32°F	Length	Width	Height	Weight (lbs.)
78DT	78DT-HD	800	960	10-11/16	7-1/16	8-1/8	54
4D	4D-HD	1000	1200	19-9/16	8-5/16	10	95
8D	8D-HD	1300	1560	20-3/4	11	10	117

Deep Sea Battery Charger



The DSEBC2410Ei is an enclosed intelligent battery charger designed to work with multiple battery types across a wide range of applications.

The advanced technology has been developed to automatically detect system settings and charging profiles including cell voltage and boost voltage to provide high-levels of charging support.

A comprehensive range of input and output protections ensure a continued safe charging environment also enabling the use of the charger as a power supply.

Key Benefits

- Fully flexible to maximize the life of the battery
- Suitable for a wide range of battery types
- NFPA110 Compliant
- Fault output
- Maximum 91% operating efficiency
- No external intervention for boost mode
- Multiple chargers can be linked together to provide larger current output
- Can be permanently connected to battery and utility supply. No need to disconnect through high load conditions.
- cULus Listed



Advanced Features

- Intelligent two, three and four stage charging profiles
- 12V / 24V auto voltage detection for multiple battery types
- Adjustable current limit
- Can be used as a battery charger, power supply or both at the same time
- Automatic or Manual boost and storage charge functions to help maintain battery condition
- Digital Microprocessor Technology
- Temperature compensation for battery charging
- Low Output Ripple and superb line regulation
- Available in two variants (LCD display or LCD display & analog meters)
- Full Protection
- AC input Under voltage | AC input Over voltage
- Battery charger output Over voltage | Battery charger output Over current
- Battery temperature compensation with over temperature protection
- Output short circuit and inverse polarity protection with auto recovery
- Automatic power de-rating at high ambient temperatures
- Battery charger failure indication
- Automatic Boost Mode boosts and equalizes cell charge improving battery performance and life
- Power Save Mode
- Once the battery is fully charged the chargers switch to Eco-Power to save energy consumption
- Can be integrated into external systems through MODBUS RTU using RS485
- Fully configurable via DSE Configuration Suite PC Software
- DSE2541 External remote display option

Specifications

AC Supply

Voltage Range	90V to 305V (L-N)
Frequency Range	48 Hz to 64 Hz (L-N)

DC Output Rating

Output	10ADC at 12V & 24VDC
Ripple and Noise	<1%
Efficiency	>86%
Auxiliary Output	100mA at 12VDC

Regulation

Line	<0.5%
Load	2%

Temperature Sensor Input - PT1000

Protections

Short Circuit	DC Over and Under Voltage
DC Over Current	Reverse Polarity
Over Temperature	AC Under & Over Voltage
Battery Charger Failure	

Charge Failure Relay - 3A at 30VDC Volt Free Relay

Temperature Rating

Operating Temp Rating	-30°C to +55°C (-22°F - 131°F)
-----------------------	--------------------------------

Compatible Battery Profiles

- Lead Acid	- Calcium
- Lead Crystal	- Lithium Phosphate
- Ni-Cad 18 Cell	- VRLA-AGM
- Ni-Cad 20 Cell	- VRLA-GEL

Factory Load Test

Blue Star Power Systems, Inc. factory testing is performed with the same extreme diligence and attention to detail that is given to the prototype testing process. Every engine generator set receives a complete factory load test that certifies and ensures that the set will function in accordance to every specific application. Test metering will have an accuracy of 1.3% or better. This metering equipment is calibrated annually, and is directly traceable to the National Institution of Standards & Technology (NIST). All test procedures are conducted in accordance with MIL-STD-705C where applicable.



Factory Acceptance Testing Procedures

- Insulation Resistance Test (301.1c)*
- High Potential Test (302.1b)*
- Alternator Over Speed
- Complete Engine Inspection
- Generator Inspection
 - Winding Resistance Test (401.1b)
 - Exciter Field Stator
 - Main Field Stator
- Mounting & Coupling Inspection
- Engine Fuel System Inspection
- Engine Lube Oil System Inspection
- Engine Cooling System Inspection
- DC Charging System Inspection
- Main Output Circuit Breaker Inspection
- Anticipatory Alarms and Shutdowns Test (505.2b, 515.1b, 515.2b)
- Optional Equipment Inspection (513.2a)
- Load Test (640.1d)
 - Regulator Range Test (511.1d)
 - No Load
 - MAX Load @ 1.0 P.F. (640.2d)
 - MAX Load @ 0.8 P.F.
 - Block Loads @ 0-25%, 0-50%, 0-75%, 0-100% of rated load tests (640.2d)
- 1.0 Power Factor Max Load
- 1.0 Power Factor Max Block Load Pickup
- Full Name Plate Rated Load.
- Standard Readings Taken Every 5 Minutes.

* Performed By Alternator OEM

Standard Reading Recorded During Load Test Inspection

Run Time	AC Frequency
AC Voltage	Exciter Field Voltage
AC Amperage	Exciter Field Current
kVA	Lube Oil Pressure
kWe	Engine Coolant Temp.
Power Factor	Ambient Temp.

Factory Load Test Summary

All engine generator sets are visually inspected prior to testing. This includes a complete visual/mechanical inspection to ensure that all fasteners and electrical connections are secure, that all rotating components are free of obstruction/interference and are properly guarded.

Once the unit is started, the AC voltage and frequency are set to rated values. The unit is operated at no load while all of the safety shutdowns and warnings are verified and tested. The unit is then restarted and run at 25%, 50% and 100% of rated load and power factor until the engine temperature has stabilized for at least ten minutes. During the rated and maximum load pickup portion of the test, the voltage regulator gain, stability and under frequency compensation adjustments are set for optimal performance. All test procedures are performed in accordance with MIL-STD-705C where applicable.

Throughout these test procedures the AC parameters, engine oil pressure, engine temperature, exhaust temperature, timing and air/fuel ratio (gaseous units) are monitored and recorded. The unit and all installed accessory equipment are continually examined for oil and coolant leaks, excessive vibration and foreign noises.

Once all test procedures are performed and recorded, the unit is allowed a cool down period prior to being shut down. The unit is once again inspected for leaks, loose fasteners and connections prior to leaving the test facility.

The unit receives another complete final inspection process prior to packaging and shipment.

Note: All units are tested after the painting process is complete to prevent unforeseen difficulties resulting from the painting process being performed after testing.

Witnessed Factory Load Test

Standard witnessed factory load testing must be scheduled and approved at least four weeks prior to the engine generator sets scheduled shipping date. Any requests for witnessed factory load testing after this four week period may incur additional charges.

Witnessed Extended Run Factory Load Test

Witnessed extended run factory load testing must be scheduled and approved at the time of order placement. Any requests for witnessed extended run factory load testing after this time could be denied and would if approved incur additional cost.

All units are built and tested to cUL, CSA and NFPA 110 standards.



Engine Generator Set Two (2) Year 2000 Hour Standby Limited Warranty



Your Blue Star Power Systems, Inc. product has been designed and manufactured with care by people with many years of experience. Blue Star Power Systems, Inc. warrants to its Buyer that the product is free from defects in materials and/or workmanship for the period of time outlined below. If the product should prove defective within the time period outlined below, it will be repaired, adjusted or replaced at the option of Blue Star Power Systems, Inc., provided that the product, upon inspection by Blue Star Power Systems, Inc., has been properly installed, maintained and operated in accordance with Blue Star Power Systems, Inc.'s Installation and Operating Manuals. This limited warranty is not valid or enforceable unless: (1) all supporting maintenance records are kept on file with the end user and made available upon request from factory, and (2) the generator set is routinely exercised in accordance with operating instructions. This warranty does not apply to malfunctions caused by physical damage, misuse, improper installation, repair or service by unauthorized persons, or normal wear and tear. The warranty is not assignable.

Blue Star Power Systems, Inc. product warranty period: Engine generator set: Parts and Labor for two (2) years from the date of factory invoice or 2000 hours (whichever occurs first). Accessories (installed on the engine generator set or shipped loose): Parts and Labor for one (1) year from the date of factory invoice or 2000 hours (whichever occurs first). Transfer Switches: If purchased with a generator set (same order number): Parts and Labor for two (2) years from the date of factory invoice or 2000 hours (whichever occurs first).

The start of the warranty period can be adjusted to the date of unit start-up (limited to 180 days from invoice date) provided that the following information is provided to Blue Star Power Systems, Inc. within 30 days of start-up. The warranty will not be effective unless a copy of the Blue Star Power Systems, Inc. start-up validation checklist is properly and completely filled out and returned to Blue Star Power Systems, Inc. within 30 days of start-up. Additionally, the engine manufacturer's engine registration form must be completed and returned to the engine manufacturer as stated in the instructions with the registration form.

To obtain warranty service: Contact your nearest Blue Star Power Systems, Inc. Service Representative. For assistance in locating your nearest authorized service representative, contact Blue Star Power Systems, Inc., Attention: Service Department (see contact information below).

Warranty service may be performed by authorized Blue Star Power Systems, Inc. service providers only. Service work performed by unauthorized persons will void all warranties.

Blue Star Power Systems, Inc. shall not be liable for any claim in amount greater than the purchase price of the product. In no event shall Blue Star Power Systems, Inc. be held liable for any special, indirect, consequential or liquidated damages including but not limited to: loss of profits, loss of time, increased overhead, delays, loss of business opportunity, good will, or any commercial or economic loss.

Blue Star Power Systems, Inc. shall not be liable for any claim that requires replacement of engine, part, or component of the gen-set that is no longer manufactured or available. Additionally, Blue Star Power Systems, Inc. will not be liable for any engine replacement that may require emissions tier level change.

THERE ARE NO EXPRESS WARRANTIES OTHER THAN THOSE DESCRIBED HEREIN. THERE ARE NO OTHER WARRANTIES, EXPRESSED OR IMPLIED, OR OTHERWISE CREATED UNDER THE UNIFORM COMMERCIAL CODE, INCLUDING BUT NOT LIMITED TO WARRANTIES OF MERCHANTABILITY, OR WARRANTIES OF FITNESS FOR A PARTICULAR PURPOSE.

The following items and/or circumstances are excluded from this limited warranty:

- ▶ Engine starting batteries: The battery manufacturers' warranty applies. Consult your local battery supplier for warranty service.
- ▶ Fuel system and/or governing system adjustments performed during or after start-up.
- ▶ Normal maintenance items: Consumable items such as belts, filters, fluids, and hoses.
- ▶ Adjustments and tune-ups performed during start-up or thereafter. Start-up, training, tuning, and adjustments for any paralleling or bi-fuel system.
- ▶ Loose connections (electrical and mechanical) not found during start-up.
- ▶ All fluid level related items including low coolant not found during start-up or checked during regular maintenance intervals.
- ▶ Shipping damage of any type. All equipment is shipped F.O.B. Blue Star Power Systems, Inc. and risk of loss transfers to the carrier once loaded for shipment. It is the responsibility of the receiving party to sign for the receipt of, and note any shipping damage to the equipment. Freight damage claim filing is the responsibility of the receiving party. In the rare event that damage occurs during shipment, Blue Star Power Systems, Inc. will not warrant any damage to the unit resulting from shrink wrap.
- ▶ Any special access fees, equipment, requirements or after hours scheduling to gain access to the equipment for warranty service purposes.
- ▶ Buyer requested rental generators used while warranty work is being performed.
- ▶ Damages caused by acts of nature, such as lightning, wind, flood, or earthquake.
- ▶ Any damage due to situations beyond the control of the manufacturing and/or workmanship of the product.
- ▶ Use of non-protected steel enclosure within 10 miles of the coast.
- ▶ Improper installation or operation as outlined in the Installation and Operation Manuals.
- ▶ Misapplication of the equipment such as usage outside the original design parameters as stated on the nameplate of the equipment.
- ▶ Equipment purchased at the standby rating that is being used in a prime power application(s).
- ▶ Diesel engine "Wet Stacking" or Regeneration issues due to lightly loaded diesel engines.
- ▶ Travel labor and mileage for mobile generator sets.
- ▶ More than one trip to the job site because a service vehicle was not stocked with normal service parts.
- ▶ Lodging expense associated with unit repair and excessive mileage charges (limit to 300 miles round trip from nearest service center).
- ▶ Failure to properly exercise and maintain your equipment per manufacturer's specifications will void all warranty.
- ▶ Equipment modifications made without the written consent of Blue Star Power Systems, Inc. will void all warranties.
- ▶ Any equipment or components added including fuel tanks and enclosures not installed at the Blue Star Power Systems, Inc. factory.

This agreement is deemed made and executed in North Mankato, Nicollet County, Minnesota and shall be construed and interpreted in accordance with the laws of the state of Minnesota without giving effect to its conflicts of laws principals. Each of the parties submits to the exclusive personal jurisdiction and venue with respect to any action or proceeding arising out of, in connection with, relating to, or by reason of this agreement before the district court of the state of Minnesota, located in Nicollet County and agrees that all claims in respect of the action or proceeding may be heard and determined in any such court.